

## General Information

The Micron MQ2 utilises advanced dual stage water filtration technology through a compact, quick-change system with dedicated high loop chrome faucet. This highly efficient and stylishly designed filter will transform your ordinary tap water into clear great tasting drinking water by effectively reducing chlorine as well as heavy metals and harmful chemicals while still maintaining essential minerals! It's easy to enjoy the many health benefits that come from using this product because it can be fitted under any kitchen sink without taking up too much space - perfect if you have limited space. Designed for mains water.

## Features and Benefits

- Featuring advanced dual stage filtration technology.
- Reduces chlorine, Trihalomethane (THM's), chemicals, heavy metals, VOCs, bad taste, odours, dirt, rust and sand.
- Filtrations down to 5 micron\*.
- Maintains essential natural minerals and fluoride.
- Easy, slimline and quick-change cartridge design.
- Mounts vertically or use hanging options- no shelf cut-outs or drilling required- perfect for rentals.
- Slimline design is perfect where there is limited under-bench space.
- High loop chrome plated dedicated faucet included.
- All plumbing installation fittings included- no additional parts needed.
- Compatible with a 3 way mixer for aesthetic addition to your kitchen.
- WaterMark approved WM032240 WMTS 103

## Cartridge Replacement and Timeframe Suggestions

MT-05 Cartridge- 5 micron PP sediment Filter to be replaced every 6 months.

MT-33 Cartridge- Coconut Shell Activated Carbon Filter (GAC) Filter to be replaced every 6-12 months.



MQ2 Specifications	
<b>Model</b>	MQ2
<b>Faucet Model</b>	PV803
<b>Flow Rate</b>	1.5 LPM
<b>Micron Rating</b>	5 Micron
<b>Min/Max Pressure</b>	100-550KPa (Must not freeze/ cold water only)
<b>Min/Max Temperature</b>	4-42 C
<b>Connection</b>	Standard size: 1/4 " Quick Connect Optional size: 3/8" Quick Connect
<b>Tap Hole</b>	12.5mm
<b>Dimensions</b>	18cm (L) x 8cm (W) x 36 cm (H)
<b>Warranty</b>	2 Years*

Important note: Use only genuine Micron Water Filters cartridge. \* 2 year warranty is 1 year parts and labour with an additional 1 year for parts only. The warranty excludes cartridges. \* Micron Rating is nominal.

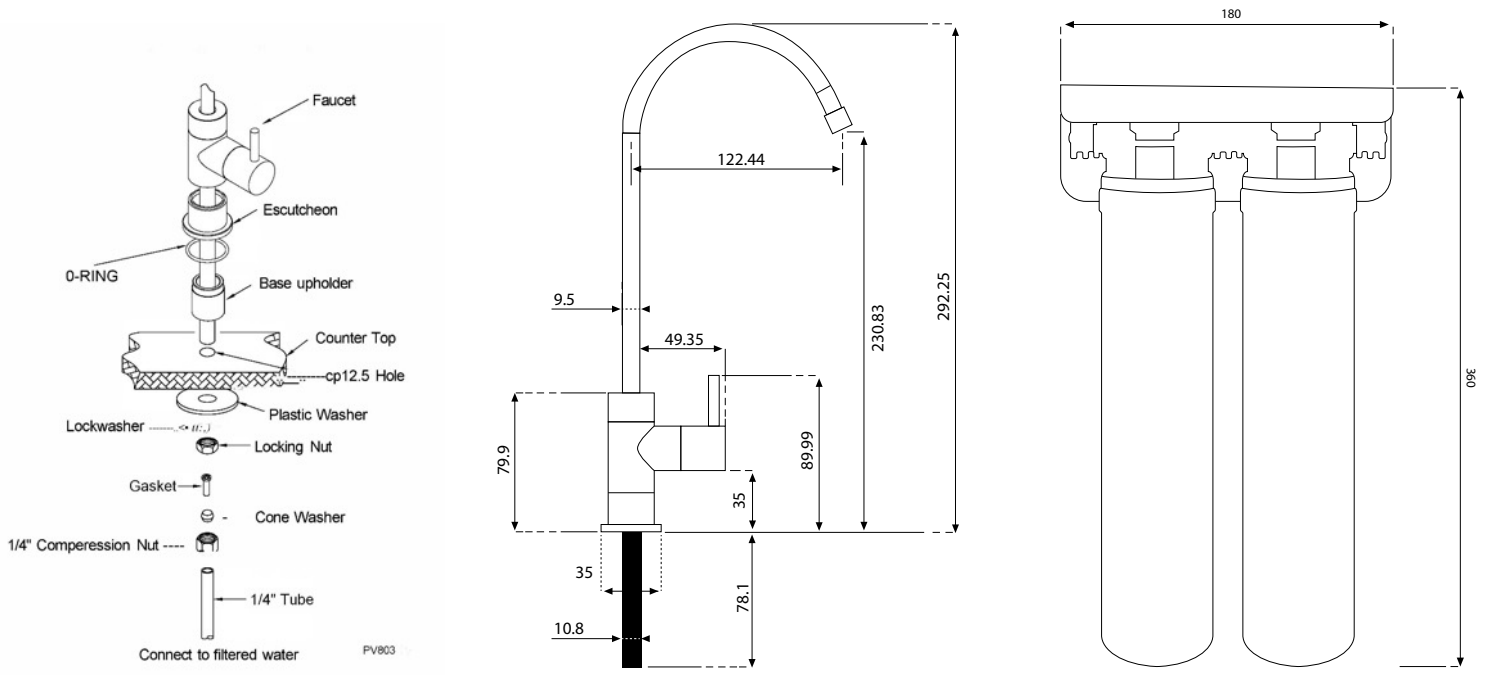

Measurements in millimetres