

# AW9220

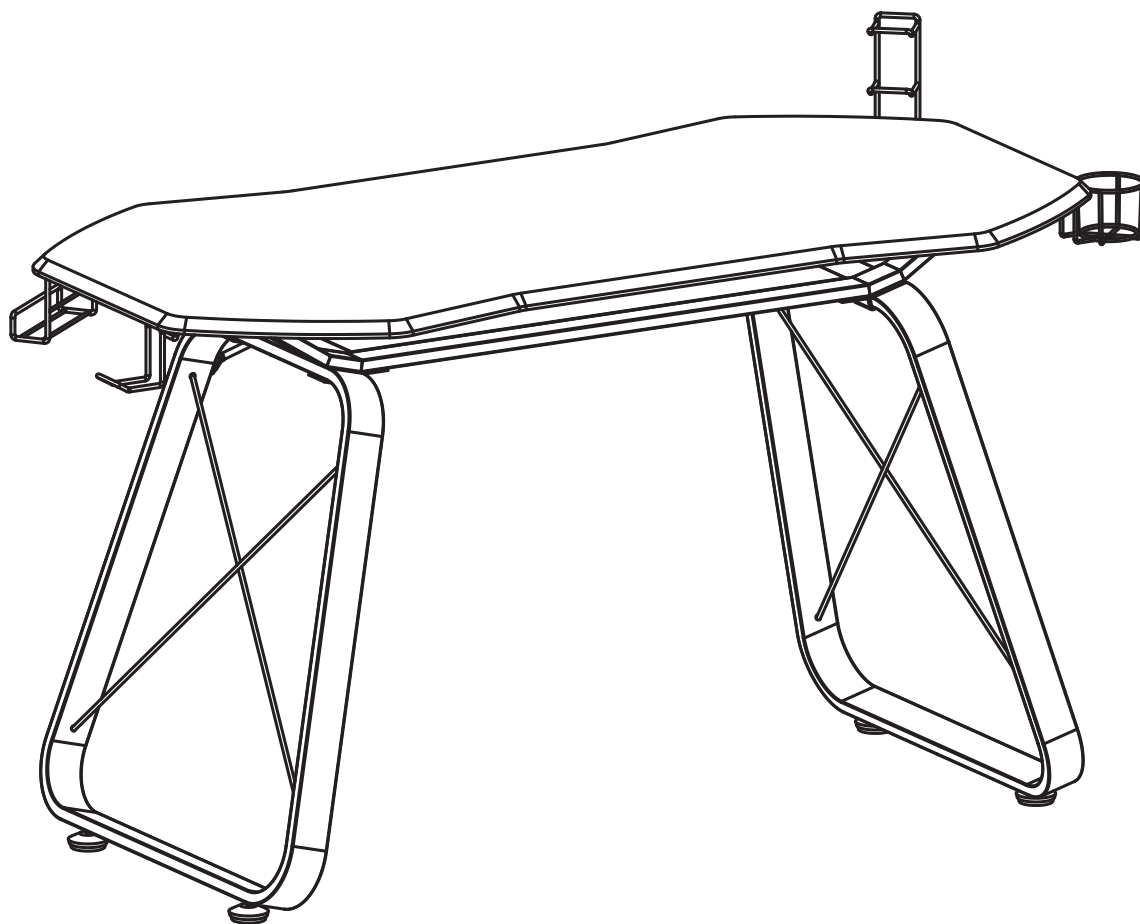

## Customer services:



01942 524 100



[cseurope@dorel.com](mailto:cseurope@dorel.com)



Dorel Home Furnishings Ltd.  
Building 4, Imperial Place, Maxwell Road,  
Borehamwood WD6 1JN United Kingdom.

REFERENCE NO:

Please retain this booklet as you will be asked  
to quote this number for any warranty or  
product related queries

# AW9220

**Thank you for purchasing this desk. Please read the instructions carefully before use to ensure safe and satisfactory operation of this product.**

## **Pre-assembly preparation**

Please ensure instructions are read in full before attempting to assemble this product

## **Necessary Tools**

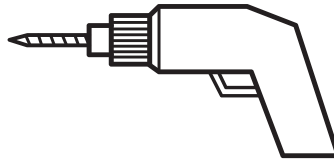

Note: Some of the tools shown here are optional and are required only for quick assembly of this product

Please check the pack contents before attempting to assemble this product. A full checklist of components is given in this leaflet. If any components are missing, please contact the retailer from whom you bought this product.

This product is **HEAVY**, it should be assembled as near as possible to the point of use. **TAKE CARE WHEN LIFTING** to avoid personal injury and (or) damage to the product.

This product takes approximately **30 MINUTES** to assemble with **2 PEOPLE**.





The fittings pack contains **SMALL ITEMS** which should be **KEPT AWAY FROM YOUNG CHILDREN**.

Read this leaflet in full before commencing assembly.

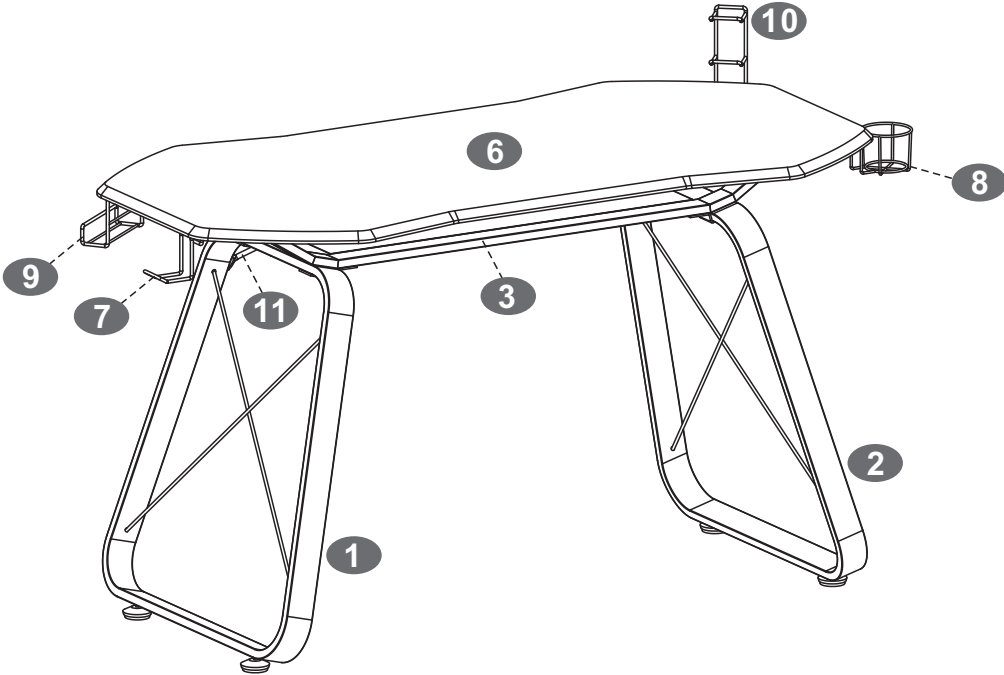

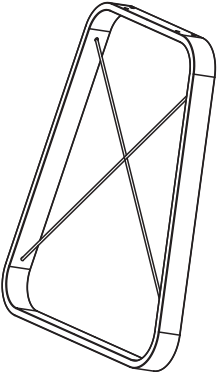
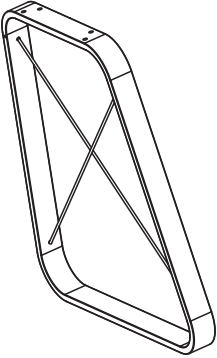
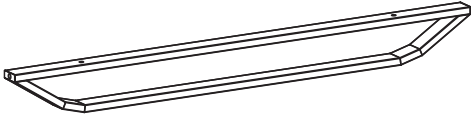
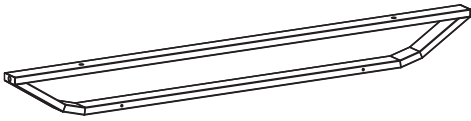

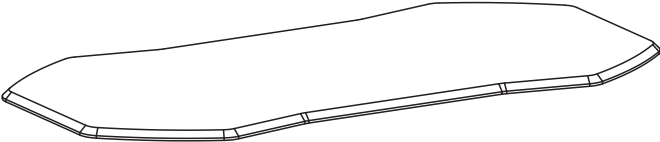
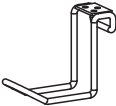
# AW9220

## ■ PARTS LIST



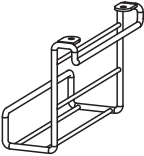
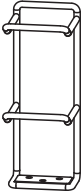
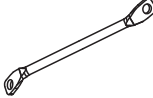







 <p>X1</p>	 <p>X1</p>	 <p>X1</p>
		 <p>X1</p>
		 <p>X1</p>
 <p>X1</p>	 <p>X1</p>	 <p>X1</p>

# AW9220

 <p>9</p> <p>X1</p>	 <p>10</p> <p>X1</p>	 <p>11</p> <p>X1</p>	 <p>12</p> <p>X1</p>
 <p>13</p> <p>X2</p>	 <p>14</p> <p>X2</p>	 <p>15</p> <p>X4</p>	

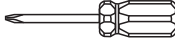
# AW9220

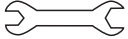
## ▪SCREWS LIST

PART	QTY.	ITEM		PART	QTY.	ITEM	
<b>A</b>	12	6X15 MM		<b>F</b>	20	Φ 10 MM	
<b>B</b>	4	6X25 MM			1	<b>M 4</b>	
<b>C</b>	8	6X30 MM			1		
<b>D</b>	11	4X14 MM			1		
<b>E</b>	4	6X40 MM					

### 6X40MM BOLT INSTALLATION AS BELOW:

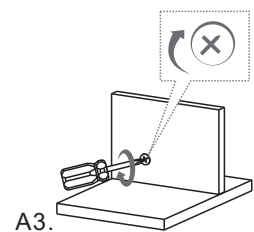
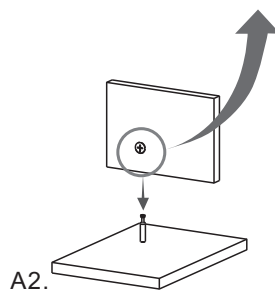
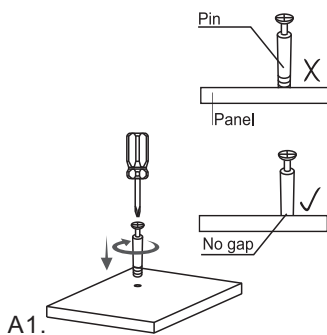
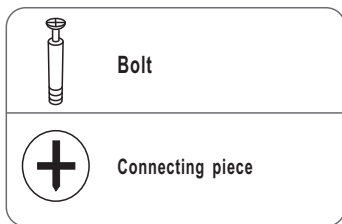

# AW9220

## ASSEMBLY STEPS:

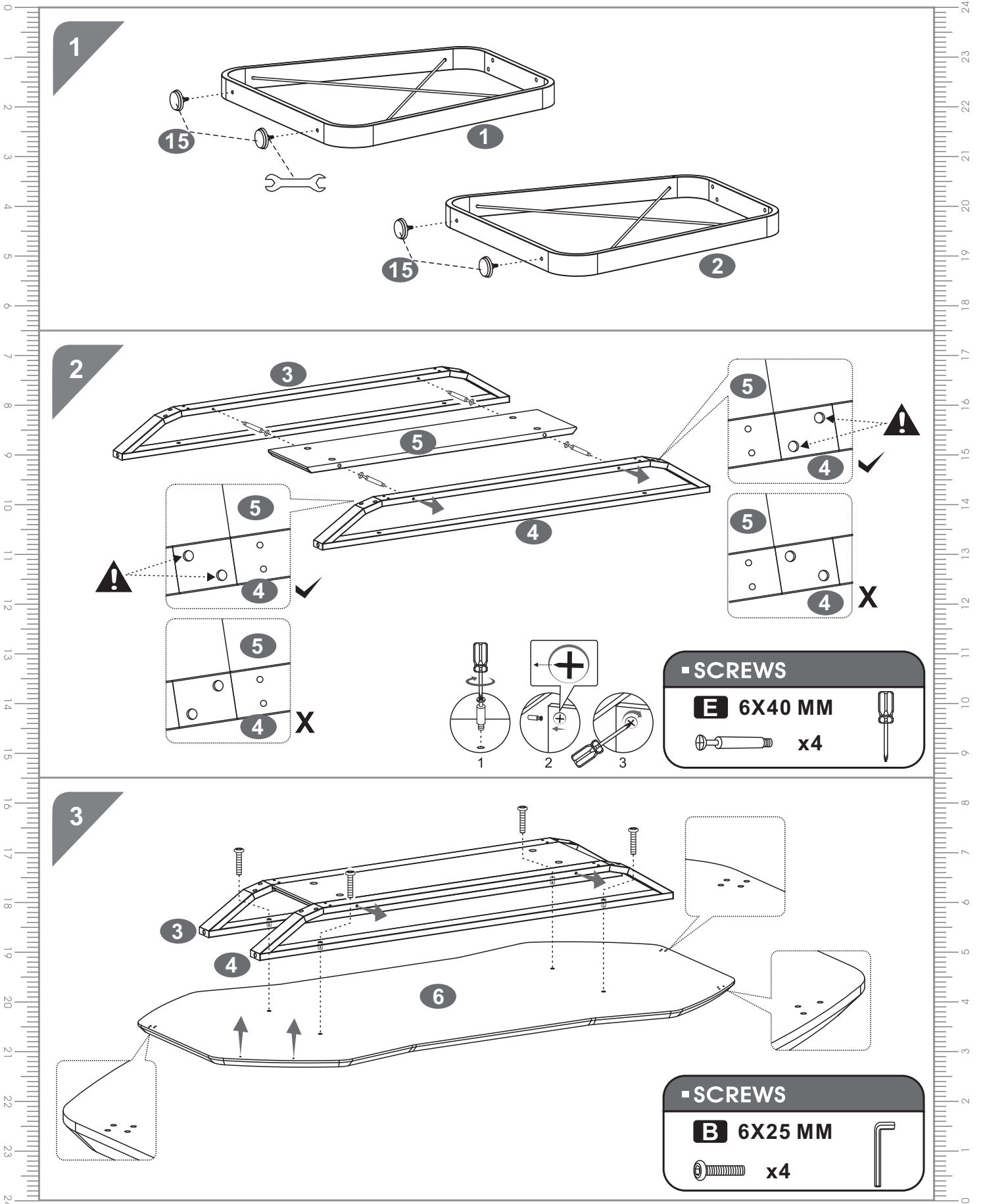

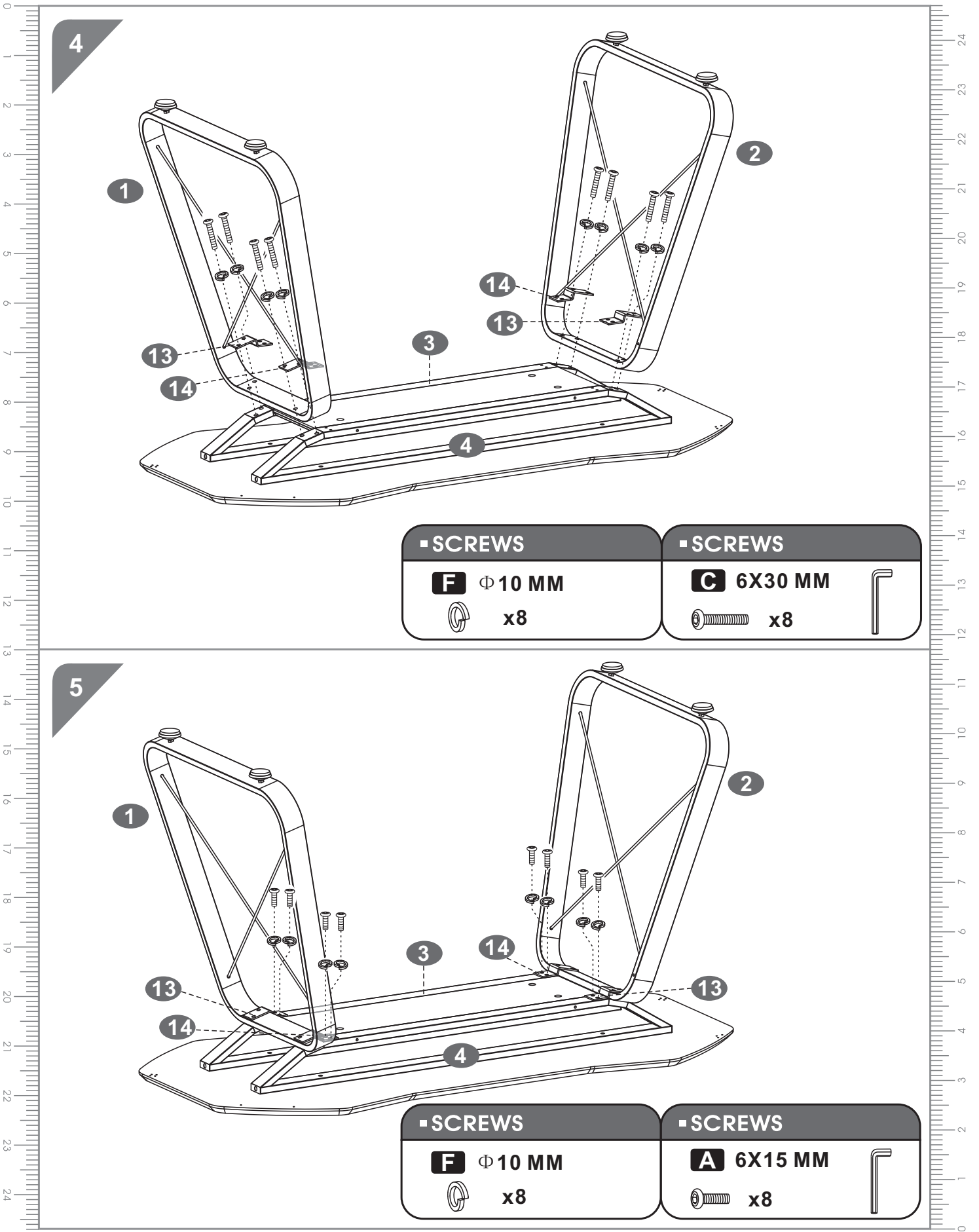

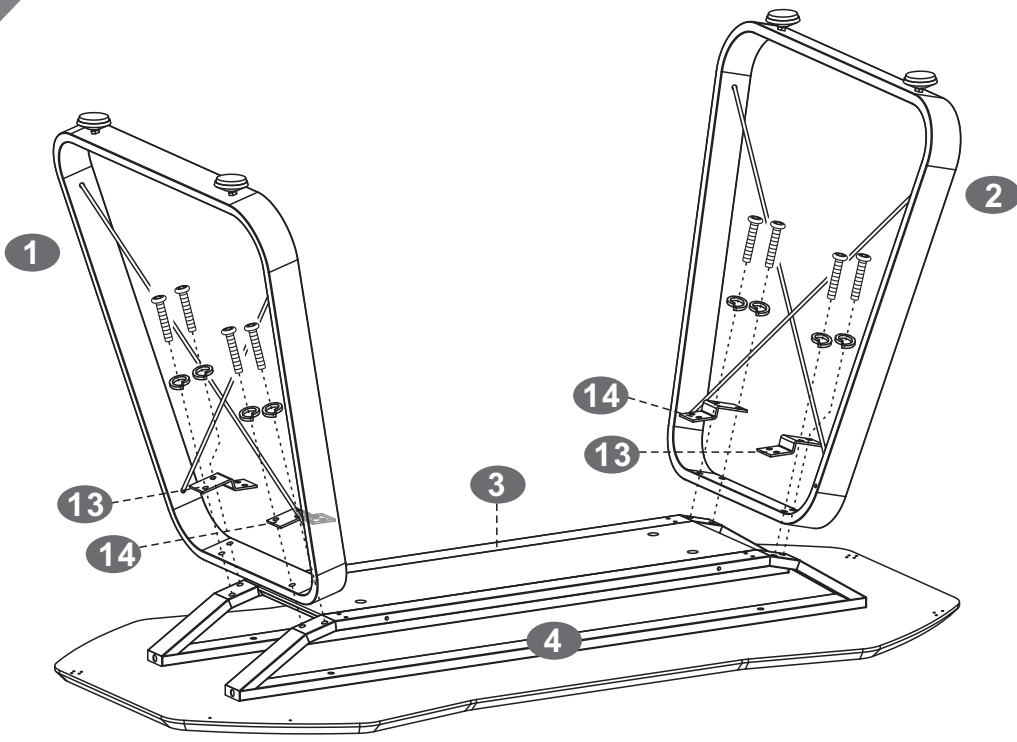

4



▣ SCREWS

**F**  $\Phi$  10 MM  
 x8

▣ SCREWS

**C** 6X30 MM  
 x8



5

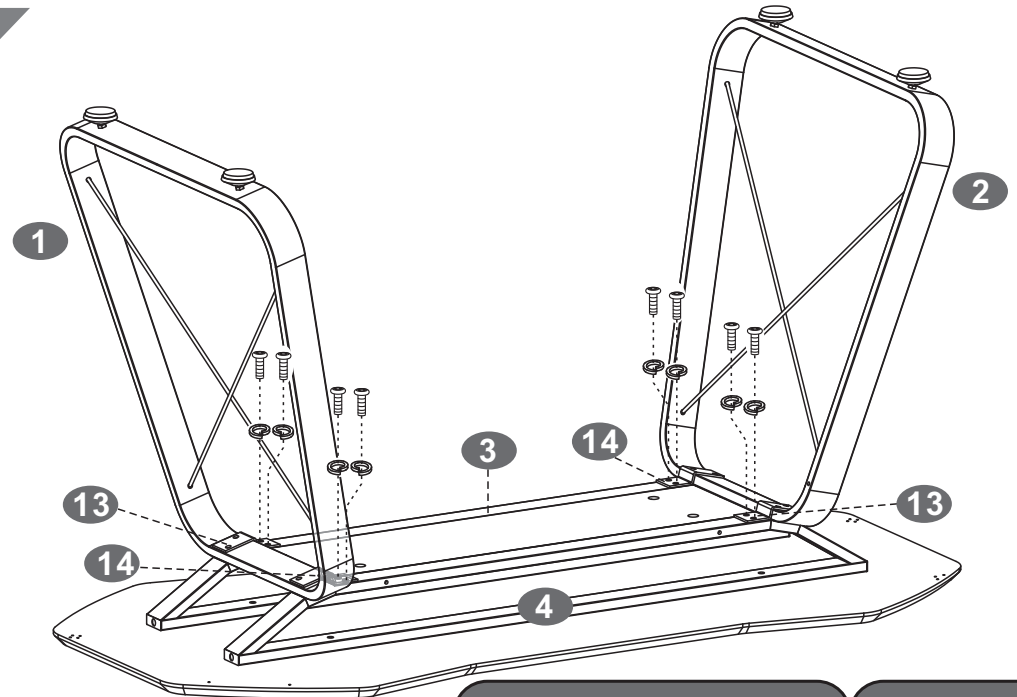

▣ SCREWS

**F**  $\Phi$  10 MM  
 x8

▣ SCREWS

**A** 6X15 MM  
 x8



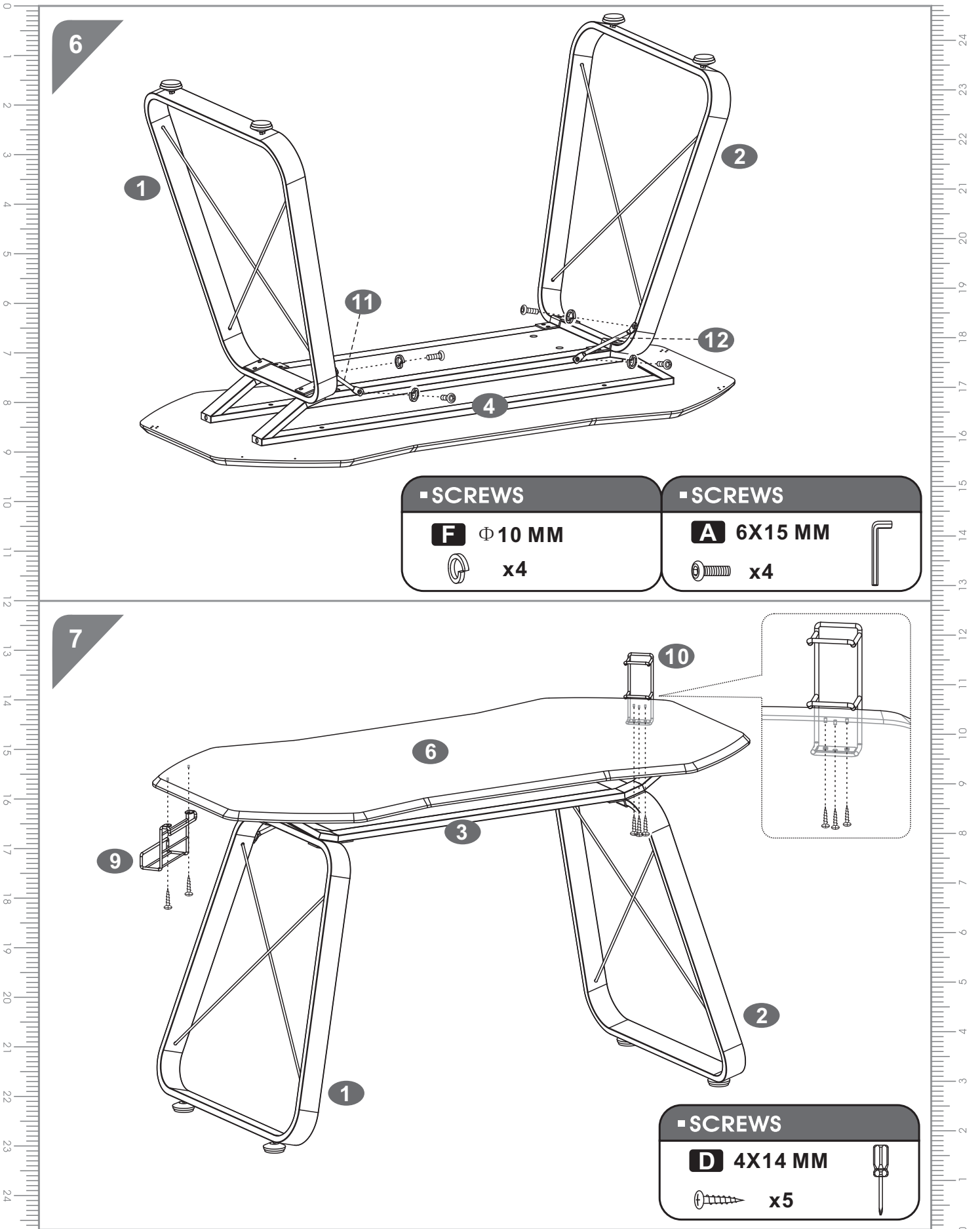



# AW9220

