

Owner's Manual

TrenchBadger[®] PRO series

EFCO 2-cycle Engine



Please read the operator's manual carefully and make sure you understand the instructions before using the machine.

CONTENTS

CONTENTS	2	FUELING	14
INTRODUCTION.....	3	Oxygenated Gasoline.....	14
Dear customer,	3	Alkylate Gasoline.....	14
SAFETY AWARENESS	4	Fuel Mixture	14
A FEW WORDS ABOUT SAFETY	4	Filling the Tank	14
SYMBOLS	4	STARTING THE ENGINE	15
THE OPERATOR'S MANUAL.....	5	Starting Warm Engine.....	15
ENVIRONMENTAL AND OPERATIONAL WARNINGS.....	5	Breaking-in the Engine.....	15
IMPORTANT MESSAGE TO EMPLOYERS	6	STOPPING THE ENGINE.....	15
STATE AND LOCAL REQUIREMENTS	6	GENERAL WORKING INSTRUCTIONS.....	16
GENERAL SAFETY PRECAUTIONS.....	6	Preparation for Trench/Bed Cutting	16
FUEL HANDLING.....	7	Safety Harness Adjustment	16
OPERATIONAL SAFETY	7	Basic Safety Rules.....	16
Kickout.....	8	Check Before Starting.....	16
Maintaining Control.....	8	WORKING TECHNIQUES.....	17
First Aid Kit	8	Trenching	17
Machine Safety Equipment.....	8	Bed Cutting.....	17
Throttle Lockout	9	MAINTENANCE	18
Stop Switch.....	9	CARBURETOR ADJUSTMENT	18
Trenching Deflector	9	Idle Speed Adjustment	18
Vibration Damping.....	9	FUEL FILTER	19
Centrifugal Clutch	10	AIR FILTER.....	19
Harness Strap	10	STARTER UNIT	19
ASSEMBLY.....	11	ENGINE	19
PRODUCT AND COMPONENT VIEWS	11	SPARK PLUG.....	19
Accessories and Layouts	11	MUFFLER	20
PRODUCT ASSEMBLY	13	GEARBOX.....	20
Assembly of the Top Deflector.....	13	DEFLECTORS	20
Assembly of the Gearbox.....	13	CONTINUAL MAINTENANCE ADVISABLE	21
Assembly of the Front Deflector	13	TROUBLESHOOTING	22
Assembly of the V-Trench Blades.....	13	STORAGE	24
Assembly of the Handle	13	TECHNICAL DATA.....	24
OPERATION.....	14		

INTRODUCTION

Dear customer,

Congratulations on your selected TrenchBadger product! We are certain you will be pleased with your purchase of one of the finest handheld trenchers/bed cutters on the market.

TrenchBadger is the first to bring a hand held, stand-up ergonomic trencher/bed cutter to the outdoor power equipment consumers for both the lawn and garden and building and construction industry, with safety and quality as our highest priority.

We are convinced that you will appreciate the quality and performance of our product for many projects to come. The purchase of one of our products gives you access to professional help for operational guidance and repair and service whenever this may be necessary.

We want to help you get the best results from your new trencher/bed cutter and to operate it safely. This manual contains the information on how to do that - please read it carefully. Think of this operator's manual as a valuable document. By following its' content (assembly, environmental awareness, operation, maintenance, etc.) the life span and the second-hand value of the machine can be extended. If you lend, rent or sell this machine, make sure that the new operator receives the owner's manual.

Thank you for using a TrenchBadger product.

TrenchBadger has a policy of continuous development and product improvement and therefore reserves the right to modify the design and appearance of products without prior notice.

Best Wishes,

TrenchBadger, Inc.

SAFETY AWARENESS

A FEW WORDS ABOUT SAFETY

Your safety, and the safety of others, is very important. And using this trencher/bed cutter safely is an important responsibility.

To help you make informed decisions about safety, we have provided operating procedures and other information on labels and in this manual. This information alerts you to potential hazards that could hurt you or others.

Of course, it is not practical or possible to warn you about all the hazards associated with operating or maintaining a trencher/bed cutter. You must use your own good judgment.

You will find important safety information in a variety of forms, including:

- **Safety Labels**—on the trencher/bed cutter.
- **Safety Messages**—preceded by a safety alert symbol and one of three signal words: DANGER, WARNING, or CAUTION.
- **Safety Headings**—such as IMPORTANT SAFETY INFORMATION.
- **Safety Section**—such as TRENCHER SAFETY.
- **Instructions**—how to use this trencher/bed cutter correctly and safely.

This entire book is filled with important safety information—please read it carefully!

Note: Illustrations and specifications in this manual may vary according to Country requirements and are subject to change without notice by the manufacturer.

SYMBOLS

These signal words mean the following, if you don't follow instructions:

-  **DANGER**
-  **WARNING**
-  **CAUTION**

You WILL be KILLED or SERIOUSLY HURT
You CAN be KILLED or SERIOUSLY HURT
You CAN be HURT



Your manual contains special messages to bring attention to potential safety concerns, machine damage as well as helpful operating and servicing information. **PLEASE READ ALL THE INFORMATION CAREFULLY TO AVOID INJURY AND MACHINE DAMAGE.**



When operating this equipment, always wear:

- A protective helmet where there is a risk of falling objects
- Approved hearing protection
- Approved eye protection



Wear non-slip, heavy-duty protective gloves when operating and handling the blades.



Wear safety shoes or boots having skid-proof sole and anti-piercing / steel toed inserts.



Watch out for thrown objects and ricochets.



The operator of the machine must ensure, while working, that no persons or animals come closer than 50ft (15m).

Kickback - Machine can be thrown violently up or to the side when the blade comes into contact with a fixed object. The blade is capable of amputating an arm or leg. Always keep people and animals at least 50ft (15m) from the machine.

SAFETY AWARENESS

THE OPERATOR'S MANUAL

Your operator's manual is for your protection. READ IT. Keep it in a safe place for reference. Know what you are doing before you begin assembly of the unit. Proper preparation and upkeep go hand-in-hand with satisfactory performance of the trencher/bed cutter and safety.

Contact your dealer or the distributor for your area if you do not understand any of the instructions in this manual. In addition to the operating instructions, this manual contains paragraphs that require your special attention.

ENVIRONMENTAL AND OPERATIONAL WARNINGS



WARNING: To ensure safe and correct operation of the trencher/bed cutter, this operator's manual should always be kept with or near machine.



WARNING: Allow only persons who understand this manual and have had proper training to operate your trencher/bed cutter.



WARNING: A trencher/bed cutter can be dangerous if used incorrectly or carelessly, and can cause serious or fatal injury to the operator or others. It is extremely important that you read and understand the contents of this operator's manual.



WARNING: Under no circumstances may the design of the machine be modified without the permission of the manufacturer. Always use genuine accessories. Non-authorized modifications and/or accessories can result in serious personal injury or the death of the operator or others.



WARNING: The ignition system produces an electromagnetic field of a very low intensity. This field may interfere with some pacemakers. To reduce the risk of serious or fatal injury, persons with pacemakers should consult their physician and the pacemaker manufacturer before operating this tool.



WARNING: Muffler surfaces are very hot during and after operation of the trencher/bed cutter, keep all body parts away from the muffler. Serious burns may occur if contact is made with the muffler.



WARNING: Long-term exposure to noise can result in permanent hearing impairment. So always use approved hearing protection.



WARNING: Exposure to vibrations through prolonged use of gasoline powered hand tools could cause blood vessel or nerve damage in the fingers, hands, and wrists of people prone to circulation disorders or abnormal swellings. Prolonged use in cold weather has been linked to blood vessel damage in otherwise healthy people. If symptoms occur such as numbness, pain, loss of strength, change in skin color or texture, or loss of feeling in the fingers, hands, or wrists, discontinue the use of this tool and seek medical attention.



WARNING: The engine exhaust from this product contains chemicals known to the State of California to cause cancer, birth defects or other reproductive harm. Operate your trench/bed cutter outdoors only in a well ventilated area.

SAFETY AWARENESS

IMPORTANT MESSAGE TO EMPLOYERS

As an employer, you have a special responsibility to the people who work for you. Before you ask anyone to operate this trencher/bed cutter, you need to determine whether the operator is capable and strong enough to safely handle and control the trencher/bed cutter.

If you decide he/she is, make sure the employee(s) read and understand all instructions and warnings in this manual and on the labels before operating the trencher/bed cutter.

Allow adequate time for hands-on training by a qualified instructor, and personally supervise practice sessions, until you feel sure the employee is ready to operate the trencher/bed cutter.

Also, be sure employees wear proper clothing, eye and hearing protection, and any other gear that may be required by local ordinances or your insurance company.

Remember, too, that you are responsible for keeping the trencher/bed cutter properly maintained and in safe operating condition.

Your commitment to safety on the job can help prevent accidents and result in longer and more productive years of service.

STATE AND LOCAL REQUIREMENTS

The engine is NOT equipped with a Spark Arrester System complying with the requirements of SAE Recommended Practice J335 and California Codes 4442 and 4443. All national forest land and land managed by the states of California, Maine, Washington, Idaho, Minnesota, New Jersey and Oregon require internal combustion engines to be equipped with a spark arrester screen by law. Other states and federal agencies are enacting similar regulations. Operating this engine in a state or locale where such regulations apply, could result in a violation of the law.

GENERAL SAFETY PRECAUTIONS

• Do not handle or operate a trencher/bed cutter when you are fatigued, ill, or upset, or if you have taken alcohol, drugs, or medication. You must be in good physical condition and mentally alert. Trencher/bed cutter work is strenuous. If you have any condition that might be aggravated by strenuous work, check with your doctor before operating a trencher/bed cutter. Be more cautious before rest periods and towards the end of your shift.

- Major cases of trencher/bed cutter accidents happen when the blade or thrown objects hits the operator. While working with the trencher/bed cutter, always use safety protective approved clothing. The use of protective clothing does not eliminate injury risks, but reduces the injury effects in case of accident. Consult your trusted clothing supplier to choose equipment in compliance with legislation. The clothing must be proper and not an obstacle. Wear adherent protective clothing. Protective jackets and dungarees leggings are ideal. Do not wear loose clothing, scarves, ties or bracelets. Tie up and protect long hair (example with foulards, cap, helmets, etc.). Safety boots having skidproof sole and anti-piercing insert. Wear protective goggles or face screens. Use protections against noises: for example, noise reduction ear guards or earplugs. The use of protections for the ear requires much more attention and caution, because the perception of audible warning signals (screaming, alarms, etc.) is limited. Always remove your hearing protection as soon as the engine stops. Wear gloves that permit the maximum absorption of vibrations.
- Check the trencher/bed cutter each day to ensure that each device, whether for safety or otherwise, is functional.
- Never use a damaged, modified, or improperly repaired or assembled trencher/bed cutter. Do not remove damage or deactivate any of the safety devices. Always replace cutting tools or safety devices immediately if it becomes damaged, broken or is otherwise removed.
- Carefully plan your operation in advance. Do not begin cutting until you have a clear work area, secure footing, and a planned retreat path.
- The trencher/bed cutter must only be used for trenching to appropriate depths or bed edging. It is unadvisable to perform other types of uses.

SAFETY AWARENESS

FUEL HANDLING



WARNING: The engine exhaust from this product contains chemicals known to the State of California to cause cancer, birth defects or other reproductive harm. Operate your trench/bed cutter outdoors only in a well ventilated area.



WARNING: Fuel and fuel fumes can cause serious injury when inhaled or allowed to come in contact with the skin. For this reason observe caution when handling fuel and make sure there is adequate ventilation.



WARNING: Beware of carbon monoxide poisoning.



WARNING: Mufflers fitted with catalytic converters get very hot during use and remain so for some time after stopping. This also applies at idle speed. Contact can result in burns to the skin. Remember the risk of fire!

- To reduce the risk of fire and burn injury, handle fuel with care. It is highly flammable.
- Mix, store and transport fuel in a container approved for gasoline.
- Mix fuel outdoors where there are no sparks or flames.
- Select bare ground, stop engine, and allow cooling before refueling.
- Loosen fuel cap slowly to release pressure and to keep fuel from escaping around the cap.
- Tighten fuel cap securely after refueling. Unit vibration can cause an improperly tightened fuel cap to loosen or come off and spill quantities of fuel.
- Wipe spilled fuel from the unit and allow remaining fuel to evaporate. Move 10 feet (3 m) away from refueling site before starting engine.
- Never attempt to burn off spilled fuel under any circumstances.
- Do not smoke while handling fuel or while operating the trencher/bed cutter.
- Store fuel in a cool, dry, well ventilated place.

- Never place the trencher/bed cutter in a combustible area such as dry leaves, straw, paper, etc.
- Store the unit and fuel in an area where fuel vapors cannot reach sparks or open flames from water heaters, electric motors or switches, furnaces, etc.
- Never take the cap off the tank when the engine is running.
- Never use fuel for cleaning operations.
- Take care not to get fuel on your clothing. If you have spilt fuel on yourself or your clothes, change your clothes. Wash any part of your body that has come in contact with fuel. Use soap and water.

OPERATIONAL SAFETY



WARNING: Always hold the trencher/bed cutter with both hands when the engine is running. Use a firm grip with thumbs and fingers encircling the trencher/bed cutter handles.

- Keep all parts of your body away from the cutting attachment when the engine is running.
- Always carry the trencher/bed cutter with the engine stopped and the muffler away from your body. When transporting your trencher/bed cutter, carry from appropriate handles. When transporting in a vehicle, keep blades covered. Properly secure your trencher/bed cutter to prevent turnover, fuel spillage and damage.
- **Do not operate a trencher/bed cutter with one hand!** Serious injury to the operator, helpers, bystanders, or any combination of these persons may result from one-handed operation. **A trencher/bed cutter is intended for two-handed use.**
- Shut off the engine before setting down the trencher/bed cutter. Do not leave the engine running unattended.
- Only use the trencher/bed cutter in well-ventilated places, do not operate the trencher/bed cutter in explosive or flammable atmospheres or in closed environments. Beware of carbon monoxide poisoning.
- Always cut from a firm-footed and safe position on the ground.



WARNING: Take great care when working on sloping ground.

SAFETY AWARENESS

- Do not cut near electric cables.



WARNING: Call you local utilities before you dig. Find the local 811 call center in the U.S.

- Keep the handles dry, clean, and free of oil or fuel mixture.
- Never cut with the trencher/bed cutter above ground level.
- Never use the trencher/bed cutter without blade deflector.

Kickout

Recognize that kickout can happen. With a basic understanding of kickout, you can reduce the element of surprise which contributes to accidents.



WARNING: Avoid kickout which can result in serious injury. Kickout is the sideward, or sudden forward motion of the machine occurring when the blade contacts any object such as a log or stone, or when the wood closes in and pinches the saw blade in the cut. Contacting a foreign object can also result in loss of trencher control.

Maintaining Control

- Keep a good, firm grip on the trencher with both hands when the engine is running and don't let go. A firm grip will help you reduce kickout and maintain control of the trencher. Keep your fingers encircling the handle.
- Stand with your weight evenly balanced on both feet.
- Do not overreach. You could be drawn or thrown off balance and lose control of the trencher.



WARNING: As a trencher/bed cutter user, do not solely rely on the product's safety features. You must follow all safety precautions, instructions, and maintenance in this manual to help avoid serious injury.

- Position of handlebars, designed with correct distance with each other. The spread and position of the hands provided by this design work together to give balance and resistance in controlling the machine.

First Aid Kit

Always have a first aid kit nearby.

Machine Safety Equipment

This section describes the machine's safety equipment, its purpose, and how checks and maintenance should be carried out to ensure that it operates correctly. See the Assembly section to locate where this equipment is positioned on your machine.

The life span of the machine can be reduced and the risk of accidents can increase if machine maintenance is not carried out correctly and if service and/or repairs are not carried out professionally. If you need further information please contact your nearest service workshop.



IMPORTANT! All servicing and repair work on the machine requires special training. This is especially true of the machine's safety equipment. If your machine fails any of the checks described below you must contact your service agent. When you buy any of our products we guarantee the availability of professional repairs and service. If the retailer who sells your machine is not a servicing dealer, ask him for the address of your nearest service agent.



WARNING: Never use a machine with faulty safety equipment. The machine's safety equipment must be checked and maintained as described in this section. If your machine fails any of these checks contact your service agent to get it repaired.

SAFETY AWARENESS

Throttle Lockout

The throttle lockout is designed to prevent accidental operation of the throttle control. When you press the lock (A) (i.e. when you grasp the handle) it releases the throttle control (B). When you release the handle the throttle control and the throttle lockout both move back to their original positions. This movement is controlled by two independent return springs. This arrangement means that the throttle control is automatically locked at the idle setting.

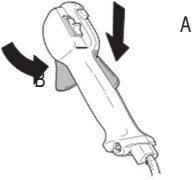

Make sure the throttle control is locked at the idle setting when the throttle lockout is released.

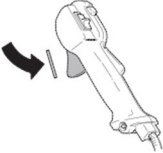

Press the throttle lockout and make sure it returns to its original position when you release it.



Check that the throttle trigger and throttle lockout move freely and that the return springs work properly.

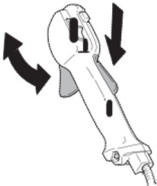

Stop Switch

Use the stop switch to switch off the engine.



Start the engine and make sure the engine stops when you move the stop switch to the stop setting.

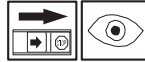

Trenching Deflector

This deflector is intended to prevent loose objects from being thrown towards the operator. The deflector also protects the operator from accidental contact with the cutting blades.

Check that the deflector is undamaged and not cracked. Replace the deflector if it has been exposed to impact or is cracked.



WARNING: Never use a cutting attachment without an approved deflector. If an incorrect or faulty deflector is fitted, this can cause serious personal injury.

Vibration Damping

Your machine is equipped with a vibration damping system that is designed to minimize vibration and make operation easier.

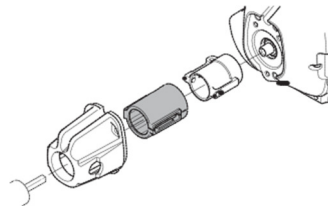

The machine's vibration damping system reduces the transfer of vibration between the engine unit/cutting equipment and the machine's handle unit.

Regularly check the vibration damping units for cracks or deformation.

Centrifugal Clutch

Your equipment is fitted with a centrifugal clutch that engages and disengages the engine from the attachment and blades based on throttle.

When throttle is applied, the clutch is engaged and rotational power is transferred to the blades. When the throttle is released, the clutch begins to disengage and remove power transfer to the blades.



WARNING: THE CUTTING ATTACHMENT SHOULD NEVER TURN AT IDLE. Turn the idle speed screw "T" counter-clockwise to reduce the idle RPM, or contact a Servicing Dealer for adjustment and discontinue use until the repair is made. Serious personal injury may result from the cutting attachment turning at idle.

A damaged clutch may cause a cutting attachment to rotate at idle speed and increase the risk of personal injury from loss of control and from contact with the cutting tool.

Harness Strap

Your equipment comes with a Harness Strap that permits the trench/bed cutter to be properly balanced and at an appropriate height from the ground.

Check that the harness strap is correctly positioned over the far shoulder and across the chest to support the balanced weight of the machine.

ASSEMBLY

PRODUCT AND COMPONENT VIEWS

Accessories and Layouts

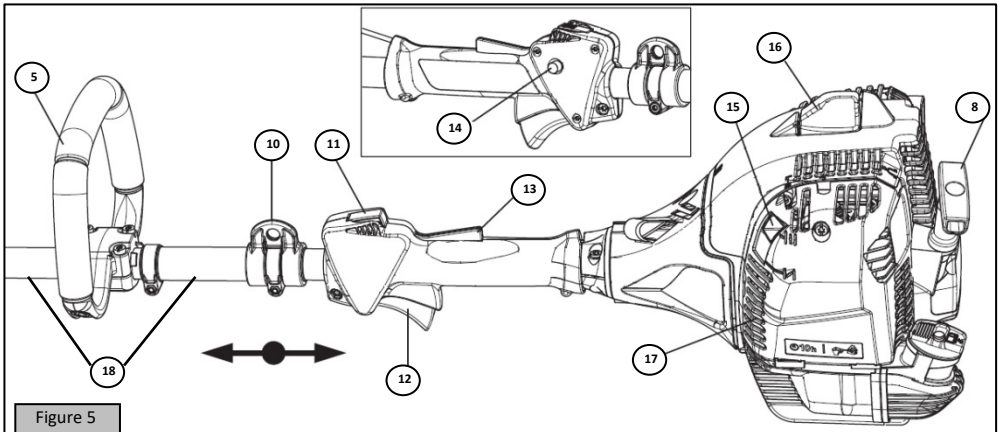
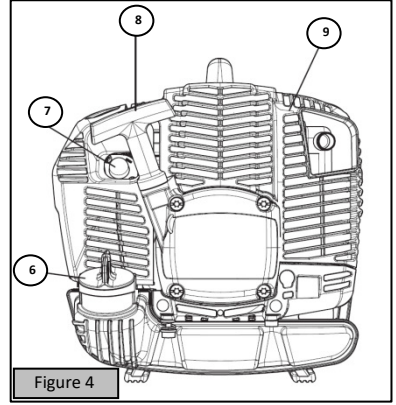
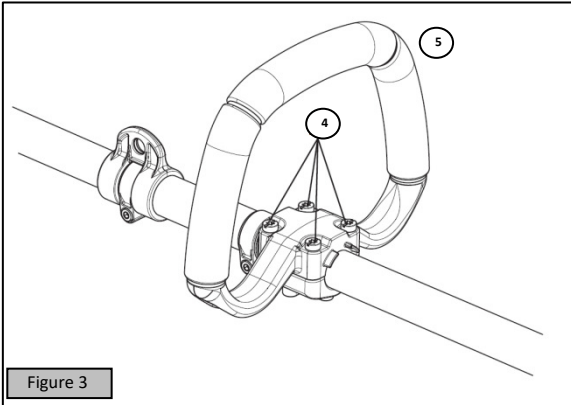
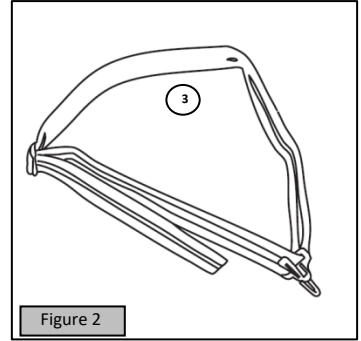
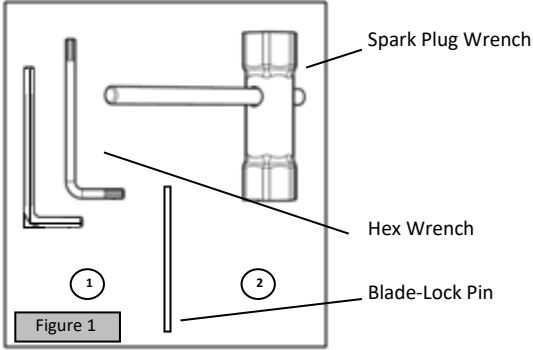

ASSEMBLY

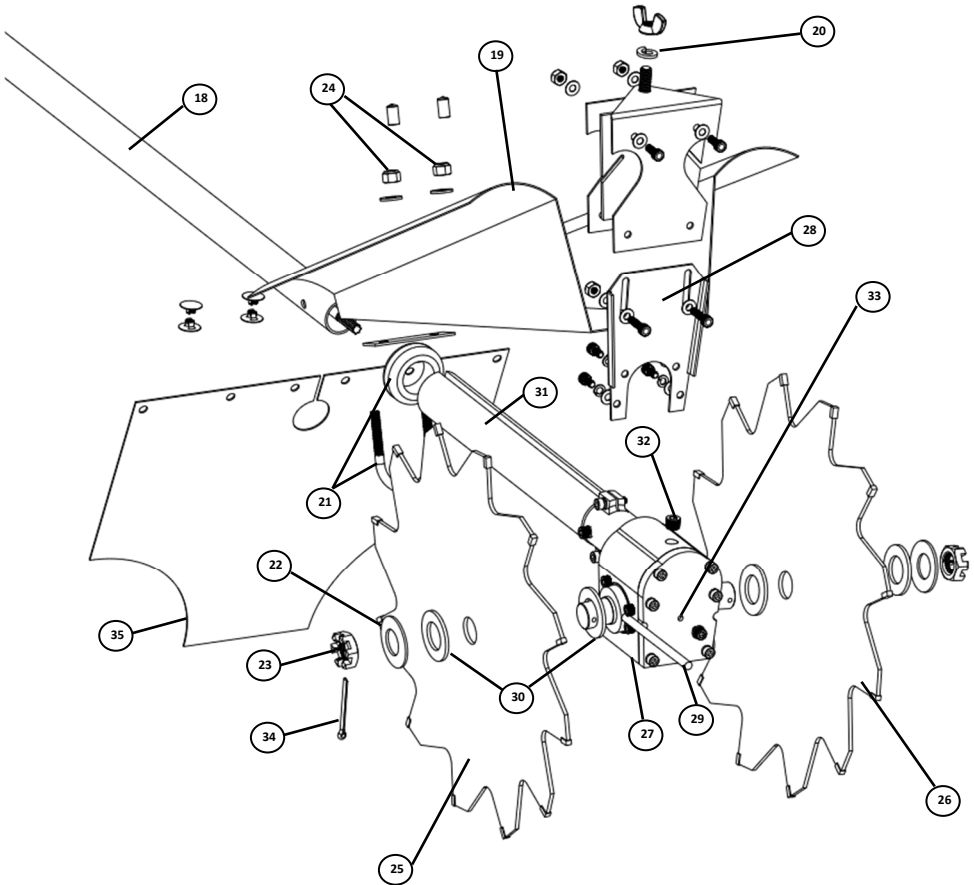

Figure 5 (some parts removed for clarity)

1-2. Supplied Tools	14. Half-throttle Button	25. RH V-Trench Blade
3. Harness	15. Choke Lever	26. LH V-Trench Blade
4-5. Handle and Mounting Screws	16. Spark Plug	27. Gear Box
6. Fuel Cap	17. Air Filter	28. Front Bridge Plate Assy
7. Fuel Purge Bulb	18. Engine Pole	29. Anti-rotation Pin
8. Pull Start Handle	19. Front 'Bikini' Deflector	30. Slip Disk (4x)
9. Muffler Guard	20. Wing Nut and Lock Washer	31. Pole Guard
10. Harness Attachment	21. U-Bolt/Grommet Assembly	32. Gearbox Fill Plug
11. STOP Button	22. Blade Belleville Washer (2x)	33. Gearbox Lub. Level Screw
12. Throttle Lever	23. Blade Castle Nut (2x)	34. Cotter Pin (2x)
13. Throttle Trigger Lockout	24. Nylon Lock Nut/Washer (2x)	35. Rubber Flap

PRODUCT ASSEMBLY



WARNING: Always stop the engine before doing any work on the trench/bed cutter. The attachment continues to rotate even after the throttle has been released. Ensure that the cutting attachment has stopped completely and disconnect the HT lead from the spark plug before you start to work on it.



WARNING: After use the bevel gear may be very hot, always wear protective gloves when performing maintenance.

Assembly of the Pole Shield

Loosen the Front Deflector Screw and slide Pole Shield (29) onto Engine Pole (18) to desired height. Position and tighten.



WARNING: Never use machine without an approved safety deflector. If an incorrect or faulty deflector is fitted, this can cause serious personal injury.



WARNING: The deflector provided with your trench/bed cutter may not protect the operator from all foreign objects (gravel, glass, wire, etc) thrown by the rotating cutting attachment. Thrown objects may also ricochet and strike the operator.

Assembly of the Gearbox

Slide Gearbox (27) onto Engine Pole (18) until Drive Shaft is fully engaged into Gearbox. Confirm full engagement on Engine Pole.

With engine sitting flat to ground level, orient bottom of Gearbox flat to ground level. Install and tighten side Set Screws to torque (32 in-lbs) – **Set Screw to align with hole in Engine Pole.** Then tighten (2x) Pole Clamp screws on Gearbox evenly until to torque (32 in-lbs).

Assembly of the Front Deflector

Install Front Deflector (19) as shown (under Bridge Plate flange). Install U-Bolt/Grommet Assy/Plate (21). Insert center holes in Rubber Flap (35) through U-Bolt and on top of Plate. Overlay Deflector on Rubber Flap. Install Wing Nut/Lock Washer (20) and Nylon Lock Nut (24) and tighten.

Assembly of Blades

Tools required: Inside: Anti-rotation, Blade Lock Pin (Tool); Outside: Wrench; pliers; side cutters.

Remove and clean all debris/dirt on blade components and Gearbox before assembly/disassembly.

- 1) Rotate Blades until Anti-rotation Arbor Hole aligns with Pin groove. Insert Anti-rotation Pin into either side to keep Shafts from rotating.
- 2) Install 'inner' Slip Disc (30) on Output Shafts.
- 3) Install Blades on respective sides where cutting teeth are facing forward/away from engine.
- 4) Install 'outer' Slip Disc (30) against Blades.
- 5) Install Blade Belleville Washer (22) (cup towards blade / Green side facing out)
- 6) Install Castle Nut (23). By hand, thread on until it securely seats against Belleville Washer.
- 7) Using a torque wrench, torque Castle Nut to 18-20ft-lbs and align slot in Castle Nut with closest hole in Output Shaft – DO NOT fully flatten Belleville Washer.
- 8) Insert Cotter Pin (34) through slot/hole – do not bend tip over yet.
- 9) With proper gloves, check for blade slippage by rotating Blade by hand. If Blade does NOT slip, remove Cotter Pin, and loosen Castle Nut by one slot. Reinsert Cotter Pin and Re-check for Blade slippage.

Note: Damage will occur to Gearbox and Drivetrain if proper Blade slippage does NOT occur. Warranty will be void.

- 10) Finish by splitting and bending long-end of Cotter Pin over Output Shaft. Snip short-end and bend toward Belleville Washer. Remove Anti-rotation Pin.



WARNING: Properly assemble the blade washers and apply proper torque to Blade Collar Nuts. Serious personal injury may result from the blades loosening during operation. If proper torque is not possible, discontinue use until the repair is made.



WARNING: Always discard a blade that is bent, twisted, cracked, broken or damaged in any other way. Never attempt to straighten a twisted blade so that it can be reused. Only use original blades of the specified type.



WARNING: Never touch or adjust the blade while the motor is running. The blade is very sharp; always wear protective gloves when performing maintenance.

Assembly of the Handle

Fit the Handle (5) onto the Engine Pole (18) and secure using the (4x) screws (4). The handle position is calculated depending on the requirements of the operator.

OPERATION

FUELING



Do Not Smoke!

This product is powered by a 2-cycle engine and requires pre-mixing gasoline and 2-cycle oil. Pre-mix unleaded gasoline and 2-cycle engine oil in a clean container approved for gasoline.

RECOMMENDED FUEL: THIS ENGINE IS CERTIFIED TO OPERATE ON UNLEADED GASOLINE INTENDED FOR AUTOMOTIVE USE WITH AN OCTANE RATING OF 89 (IR + M) / 2) OR HIGHER.

Mix 2-Cycle Engine Oil with gasoline according to the instructions on the package. We strongly recommend the use of 2% (50:1) Efco Two Cycle Engine Oil, which is specifically formulated for all Efco air-cooled two-stroke engines.

The correct oil / fuel proportions shown in the table below are suitable when using the Efco Two Cycle Engine Oil or an equivalent high quality engine oil (JASO specification FD or ISO specification L-EGD). When oil specifications are NOT equivalent or unknown use 4% (25:1) fuel / oil mixing ratio.

condensed out of humid air or be a contaminant in the fuel system, including tank.

The use of oxygenated gasoline may cause the occurrence of vapor-lock easier.

Alkylate Gasoline



CAUTION: Alkylate fuels have A different density than normal fuel. Therefore engines, set with normal fuel, need different H jet regulation to avoid critical issues. For this operation, it's necessary to be turned at a Licensed Service Dealer.

Fuel Mixture

2-Cycle Engine Oil (25:1) 4%

Gasoline	Oil
1 Gallon (US)	5.2 oz.
1 Liter	40 cc (40 ml)

2-Cycle Engine Oil (50:1) 2%

Gasoline	Oil
1 Gallon (US)	2.6 oz.
1 Liter	20 cc (20 ml)

Filling the Tank



WARNING: Follow safety instruction for fuel handling. Always shut off engine before fuelling. Never add fuel to a machine with a running or hot engine. Move at least 10 feet (3 m) from refuelling site before starting engine. **DO NOT SMOKE!**

1. Clean surface around fuel cap to prevent contamination.
2. Loosen fuel cap slowly.
3. Carefully pour fuel mixture into the tank. Avoid spillage.
4. Prior to replacing the fuel cap, clean and inspect the gasket.
5. Immediately replace fuel cap and hand tighten. Wipe up any fuel spillage.



WARNING: Check for fuel leaks. If any are found, correct before use. Contact a Servicing Dealer if necessary.

CAUTION: DO NOT USE AUTOMOTIVE OIL OR 2-CYCLE OUTBOARD OIL.



CAUTION:
- Match your fuel purchases to your consumption; don't buy more than you will use in one or two months;
- Store gasoline in a tightly-closed container in a cool, dry place.



CAUTION: For the mixture, never use a fuel with an ethanol percentage higher than 10%; gasohol (mixture of gasoline and ethanol) up to 10% ethanol or E10 fuel are acceptable.

Oxygenated Gasoline

When using an oxygenated gasoline, a good practice of fuel management is necessary.

Gasoline oxygenated with alcohol readily takes up water when it is present; the water may be

OPERATION

BASIC OPERATOR TIPS

1. Wear non-slip gloves for maximum grip and protection.
2. Maintain a proper grip on the trencher/bed cutter whenever the engine is running. The fingers should encircle the handlebar and the thumb is wrapped under the handlebar.

STARTING THE ENGINE

Place the trencher on level ground and ensure that no objects or obstructions are in immediate vicinity which could come in contact with the cutting attachment.

1. Place the trencher/bed cutter on the ground in a stable position. Check that the blade is free.
2. Slowly push the purge bulb 6 times (Fig.4, (7))
3. Pull the choke lever (Fig. 5, (15)) in the CLOSE position (A)

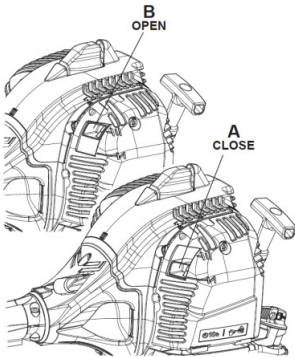

4. Hold the body of the machine on the ground using your left hand (CAUTION! Not with your foot!). Pull the starter rope until the first kick over of the engine is heard (no more than 3 pulls). A new unit may require additional pulls.

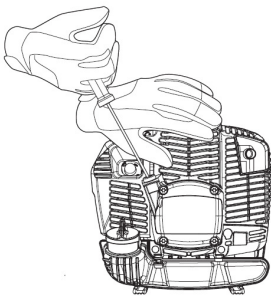

5. Push the choke lever in OPEN position
6. Pull the starter cord to start the engine.

7. Once the machine is started, warm up the machine for few seconds, without touching the throttle lever. The machine could need more seconds to warm up with cold weather or at high altitudes.



CAUTION:

- Never wrap the starter cord around your hand.
- When pulling the starter rope, do not use the full extent of the rope as this can cause the rope to break.
- Do not let starter rope snap back. Hold the starter handle and let the rope rewind slowly.



WARNING: Do not trench/cut with the choke lever at the CLOSE position. Do not operate with the starting throttle lock engaged. Cutting with the starting throttle lock engaged does not permit the operator proper control.

Starting Warm Engine

Follow above starting instructions, but do not use the CLOSE position (A) for start up again.

Breaking-in the Engine

NOTE: It is normal for smoke to be emitted from a new engine during and after first use.

The engine reaches the maximum power after 5-8 hours of activity.

During this period of breaking-in, do not make the machine function idly at full throttle, to avoid excessive functioning stress.

Keep the engine at full throttle the entire time you are trenching/cutting.



CAUTION: During the break-in period, do not vary the carburetion to obtain a presumed power increment; the engine can be damaged.

STOPPING THE ENGINE

Set the throttle lever to idle position and wait a few seconds to let the engine cool off.

Turn off the engine, pushing the ON/OFF switch (Fig. 4, (11)).

OPERATION

GENERAL WORKING INSTRUCTIONS



WARNING: This section describes the basic safety precautions for working with the trencher/bed cutter. If you encounter a situation where you are uncertain how to proceed, you should ask an expert. Contact your dealer or your service workshop. Avoid all usage which you consider to be beyond your capability. You must understand the difference between trenching and bed cutting before use.

Preparation for Trench/Bed Cutting



WARNING: The trencher/bed cutter is to be used at ground level with the cutting attachment perpendicular to the ground. Use above ground level or with the cutting attachment parallel to the ground may increase the risk of injury. Never use your trencher/bed cutter as a hedge/tree trimmer or outside its intended use.



WARNING: Neither the operator of the machine nor anyone else may attempt to remove cut material while the engine is running or the cutting equipment is rotating, as this can result in serious injury. Stop the engine and cutting equipment before you remove material that has wound around the blade/equipment as otherwise there is a risk of injury.

Safety Harness Adjustment

- Prior to operation, adjust and fit Safety Harness (Fig. 2). Lift both trencher/ bed cutter and Safety Harness Strap. Slip Safety Harness over far shoulder and across chest. Adjust harness at buckle as to carry partial load of machine.
- Safety Harness should not interfere with Throttle Control or operational movement of machine.

Basic Safety Rules

1. Look around you:
 - To ensure that people, animals or other things cannot affect your control of the machine.
 - To ensure that people, animals, etc., do not come into contact with the cutting attachment or loose objects that are thrown out by the cutting attachment.

2. Do not use the machine in bad weather, such as dense fog, heavy rain, strong wind, intense cold, etc. Working in bad weather is tiring and often brings added risks, such as icy ground, unpredictable felling direction, etc.
3. Make sure you can move and stand safely. Check the area around you for possible obstacles (roots, rocks, branches, ditches, etc.) in case you have to move suddenly. Take great care when working on sloping ground.
4. Switch off the engine before moving to another area.
5. Never put the machine down with the engine running.
6. Always use the correct equipment.
7. Make sure the equipment is well adjusted.
8. Follow the safety precautions.
9. Organize your work carefully.
10. Always use full throttle when starting to cut with the blade.
11. Always use sharp blades.
12. Avoid large stones/rocks.

Check Before Starting

- Check the blades are free to rotate without binding to each other or gearbox.
- Check the blades to ensure that no cracks have formed at the bottom of the teeth or by the center hole. Discard a blade if cracks are found.
- Check that the blade washers are not cracked due to fatigue or due to being tightened too much. Discard the washer if it is cracked.
- Ensure the blade locking nuts have not lost their captive force or too loose.
- Check Deflector and Bikini for cracks and proper mounting.



WARNING: Always discard a blade that is bent, twisted, cracked, broken or damaged in any other way. Never attempt to straighten a twisted blade so that it can be reused. Only use original blades of the specified type.

WORKING TECHNIQUES



WARNING: Watch out for thrown objects. Always wear approved eye protection. Never lean over the cutting attachment guard. Stones, rubbish, etc. can be thrown up into the eyes causing blindness or serious injury. Stop the machine immediately if anyone approaches. Never swing the machine around without first checking behind you to make sure no-one is within the safety zone.

Trenching

- Once equipment is started and engine is at idle, lift both trencher/ bed cutter and Safety Harness (Fig. 2). Slip Safety Harness over far shoulder and across chest. Confirm harness carry's partial load of machine.
- To begin trenching, start with the machine at full throttle and ease the blades into the soil until half the blade is in ground.
- Work systematically, forward, down, and backwards, trenching 3-5in of additional soil with each motion until depth is reached.
- Continue forward, down, and backwards trenching from bottom of trench depth to the top, excavating another segment of soil.
- With each forward and down trench, take a step backwards and pull trencher towards operator.

Bed Cutting

- Remove one of the trenching blades and reinstall Belleville Washer, Slips Washers, and Castle Nut.
- Once equipment is started and engine is at idle, lift both trencher/ bed cutter and Safety Harness (Fig. 2). Slip Safety Harness over far shoulder and across chest. Confirm harness carry's partial load of machine.
- At which ever end of the bed is easiest, start with the machine at full throttle and ease the blade into the soil until half the blade is in ground.
- Carefully walk backwards following the bed line and excavate soil.

MAINTENANCE



WARNING: Always wear protective gloves during maintenance operations. Do not carry out maintenance with the engine hot.



WARNING: Never repair damaged cutting attachments by welding, straightening or modifying the shape. This may cause parts of the cutting tool to come off and result in serious or fatal injuries.



WARNING: Don't try to force the screws outside the range!



WARNING: Don't modify the carburetor in any way in such case the engine will not run in compliance with emissions regulations.

CARBURETOR ADJUSTMENT

Before adjusting the carburetor, clean the cover vents and air filter as shown in Illustration. Refer to Maintenance-Air Filter Sections for details.

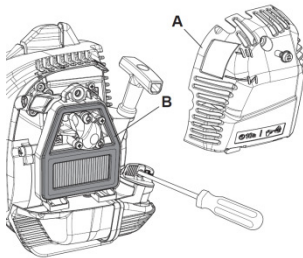

Allow the engine to warm up prior to carburetor adjustment.

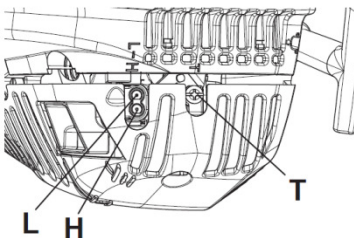

This engine is designed and manufactured in order to comply with EPA (Environmental Protection Agency) Phase 3 regulations. The carburetor is designed to permit only the adjustment of L and H screws in a range of 1/4 round; the $\pm 1/8$ round the hall range admissible for L and H screws is determined by the manufacturer and you cannot modify it.

Idle Speed Adjustment

- If the engine starts, runs, and accelerates but will not idle; turn the idle speed screw "T" clockwise to increase idle speed.
- If the cutting attachment turns at idle, turn the idle speed screw "T" counterclockwise to reduce the idle RPM and stop the cutting attachment movement. If the cutting attachment still moves at idle speed, contact a Servicing Dealer for adjustment and discontinue use until the repair is made.
- Screw L must be adjusted so that the engine promptly responds to sharp accelerations and gives good idle operation.
- Screw H must be adjusted so that the engine gives maximum power during the cutting phase.



WARNING! If the idle speed cannot be adjusted so that the cutting attachment stops, contact your dealer/service workshop. Do not use the machine until it has been correctly adjusted or repaired.

FUEL FILTER

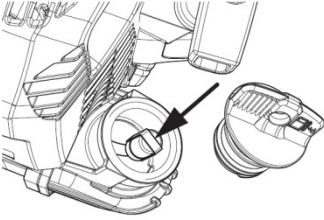

Check the fuel filter periodically. Replace it if contaminated or damaged.

AIR FILTER



WARNING: Do not clean filter in gasoline or other flammable solvent to avoid creating a fire hazard or producing harmful evaporative emissions.

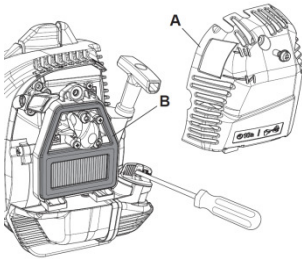

If a power drop is noticed, check the air filter. Open the air filter cover (A) and check the air filter (B) each day, change the filter if heavily clogged or damaged.

Blow with compressed air, at a distance. Reinstall the air filter into cover. Place the air filter cover onto the trencher. Tighten the air filter cover screw securely. A used air filter can never be completely cleaned. It is advisable to replace your air filter with a new one after six month of operation. Make sure the cover and the support are clean before fitting the new filter.



CAUTION: Never run the engine without the air filter, serious damage could result. Make sure the air filter is correctly placed in the air filter cover before reassembly. Always replace damaged filters. Do not clean a filter with a brush.

STARTER UNIT



WARNING: The coil spring is under tension and could fly apart causing serious injuries. Never try to disassemble or modify it.

ENGINE

Clean the cylinder fins with compressed air or a brush periodically. Dangerous overheating of engine may occur due to impurities on the cylinder.

To keep the working temperature as low as possible the machine is equipped with a cooling system.

SPARK PLUG

This engine uses a NGK BPMR7A with .02" (0.5 mm) electrode gap. Use an exact replacement and replace every six months or more frequently, if necessary.

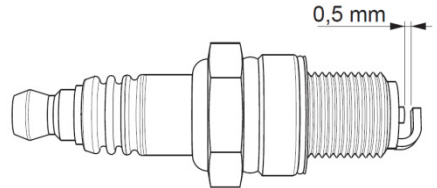

BPMR7A



WARNING: Never test the ignition system with ignition wire connector removed from spark plug or with unseated spark plug, since uncontained sparking may cause a fire. A loose connection between spark plug terminal and ignition wire connector in the boot may create arcing that could ignite combustible fumes and cause a fire.

Use only resistor type spark plugs of the approved range.

Factors such as:

- too much oil in fuel mix;
- dirty air filter;
- unfavorable running conditions (e.g. operating at part load) may result in rapid deterioration of the spark plug.

MUFFLER



WARNING: This muffler is fitted with a catalytic converter needed for the engine to be in compliance with the emissions requirements. Never modify or remove the catalytic converter: failure to do so is a violation of law.



WARNING: Mufflers fitted with catalytic converters get very hot during use and remain so for some time after stopping. This also applies at idle speed. Contact can result in burns to the skin. Remember the risk of fire!



WARNING: Do not operate your machine if the muffler is damaged, missing or modified. An improperly maintained muffler will increase the risk of fire and hearing loss.

DEFLECTORS

Inspect and clean both the Top and Bikini Deflectors in regulator intervals. Build up of debris could hide damage and/or necessary repair.

GEARBOX

Clean the Gearbox Output Shafts (between blades and Gearbox) with compressed air or a brush periodically. Overheating of Gearbox may occur due to improper ventilation.



WARNING: The Gearbox (Fig. 5, (27)) can get hot during use and may remain so for a while afterwards. You could get burnt if you touch it.

Gearbox Lubricant

The Gearbox lubricant is specifically selected for the internal gear type and material. **Lubricant level must be checked and maintained per maintenance schedule or prior to each use.**



WARNING: Use of any other lubricant type and/or manufacturer, or operating without proper lubricant level, will cause damage to internal gears and void warranty.

Proper lubricant: KLUBERSYNTH GH 6-320
Lubricant capacity: 0.5 fl. oz (15 ml)

CONTINUAL MAINTENANCE ADVISABLE

It is advisable to inspect the machine by a specialized technician at an authorized service network at the end of season, if used intensively, and every two years if with normal use.



ATTENTION: All maintenance operations not reported in this manual must be carried out by an authorized Service Center.

To ensure steady and regular trencher/bed cutter operation, remember that parts must only be replaced with ORIGINAL SPARES.

TROUBLESHOOTING

Using Troubleshooting Chart



WARNING: Always stop unit and disconnect spark plug before performing all of the recommended remedies below except remedies that require operation of the unit.

When you have checked all the possible causes listed and you are still experiencing the problem or if you are experiencing a problem that is not listed in this chart, see your Servicing Dealer.

PROBLEM	POSSIBLE CAUSE	POSSIBLE SOLUTION
Engine will not start or will run only a few seconds after starting.	<ol style="list-style-type: none"> 1. No spark 2. Flooded engine 3. Out of gas 	<ol style="list-style-type: none"> 1. Check Spark. Remove spark plug cover. Remove spark plug from cylinder. Reattach the spark plug wire and lay spark plug on top of cylinder. Pull the starter rope and watch for spark at spark plug tip. If there is no spark, repeat test with a new spark plug (BPMR7A). 2. With the ignition switch off, remove spark plug. Move choke lever to Run position and pull starter cord 15 to 20 times. This will clear excess fuel from engine. Clean and reinstall spark plug. Pull starter three times with choke lever at run. If engine does not start, move choke lever to choke and repeat normal starting procedure. If engine still fails to start, repeat procedure with a new spark plug. 3. Remove Fuel Cap and refill tank.
Engine starts but will not accelerate properly.	<ol style="list-style-type: none"> 1. Carburetor requires "L" (Low jet) adjustment. 2. Clogged air filter 	<ol style="list-style-type: none"> 1. Adjust with in allowable limits. Outside of limits, contact a Servicing Dealer for carburetor adjustment. 2. Clean per Maintenance section
Engine starts but will not run properly at high speed.	<ol style="list-style-type: none"> 1. Carburetor requires "H" (High jet) adjustment. 2. Clogged air filter 	<ol style="list-style-type: none"> 1. Adjust with in allowable limits. Outside of limits, contact a Servicing Dealer for carburetor adjustment. 2. Clean per instructions in Maintenance-Air Filter Section.
Engine does not reach full speed and / or emits excessive smoke	<ol style="list-style-type: none"> 1. Check oil fuel mixture. 2. Clogged air filter 3. Carburetor requires "H" (High jet) adjustment. 	<ol style="list-style-type: none"> 1. Use fresh fuel and the correct 2-cycle oil mix. 2. Clean per instructions in Maintenance-Air Filter Section. 3. Adjust with in allowable limits. Outside of limits, contact a Servicing Dealer for carburetor adjustment.

TROUBLESHOOTING

<p>Engine starts, runs, and accelerates but will not idle.</p>	<p>Idle Screw adjustment</p>	<p>Turn idle speed screw “T” clockwise to increase idle speed. If cutting attachment turns at idle, turn idle speed screw “T” counterclockwise to decrease speed; see Operation-Carburetor Adjustment.</p>
<p>Cutting attachment running incorrectly and with high vibration</p>	<ol style="list-style-type: none"> 1. Gearbox damaged. 2. Gearbox assembled incorrectly 3. Blade(s) assembled incorrectly 	<ol style="list-style-type: none"> 1. Replace if necessary – Contact a Servicing Dealer 2. Reassemble the Gearbox to Engine Pole with care 3. Reassembles the Blade(s) with care
<p>Engine starts and runs, but cutting attachment is not rotating</p> <div data-bbox="68 443 398 528" style="border: 2px solid black; padding: 5px; margin-top: 10px;">  <p>WARNING: Never touch the blade while the engine is running.</p> </div>	<ol style="list-style-type: none"> 1. Gearbox damaged. 2. Gearbox assembled incorrectly 3. Clutch drum damaged. 	<ol style="list-style-type: none"> 1. Replace if necessary – Contact a Servicing Dealer 2. Reassemble the Gearbox to Engine Pole with care 3. Replace if necessary – Contact a Servicing Dealer

STORAGE



WARNING: Stop engine and allow to cool, and secure the unit before storing or transporting in a vehicle. Store unit and fuel in an area where fuel vapors cannot reach sparks or open flames from water heaters, electric motors or switches, furnaces, etc. Store unit with all guards in place. Position so that any sharp object cannot accidentally cause injury to passersby. Store the unit out of reach of children and other unauthorized persons.

1. Drain and clean the fuel tank in a well ventilated area.
2. Drain all fuel from tank into a container approved for gasoline. Run engine until it stops. This will remove all fuel-oil mix which could become stale and leave varnish and gum in the fuel system.
3. Clean all foreign material from the trencher. Keep away from corrosive agents such as garden chemicals and de-icing salts.
4. Abide by all Federal and local regulations for the safe storage and handling of gasoline. Excess fuel should be used in other 2-cycle engine powered equipment.



CAUTION: It is important to prevent gum deposits from forming in essential fuel system parts such as the carburetor, fuel filter, fuel hose, or fuel tank during storage. Alcohol blended fuels (called gasohol or E10 or using ethanol, methanol) can attract moisture which leads to fuel mixture separation and formation of acids during storage. Acidic gas can damage the engine.

TECHNICAL DATA

ENGINE (Pro 12 / Pro 10):

Manufacturer: EFCO DS 3500 / DS 3000
 Displacement: 2.21 cu.in (36.3 cc) / 1.86 cu .in (30.5 cc)
 Bore: 1.50 in (38 mm) / 1.41 in (36 mm)
 Stroke: 1.36 in (32 mm) / 1.10 in (30 mm)

PERFORMANCE (Pro 12 / Pro 10):

Idle Speed: 2,800 RPM / 2,800 RPM
 WOT (With Blade): 11,700 RPM / 11,900 RPM
 Power: 1.9 HP / 1.4 kW (8,500 RPM) / 1.5 1.1 kW (7,500 RPM)

FUEL AND OIL SYSTEMS (Pro 12 / Pro 10):

Carburetor: Multi Position Diaphragm Carburetor
 Fuel Tank Capacity: 20.3 fl .oz. (600 ml) / 19.6 fl .oz. (580 ml)
 Fuel Mix: See Operation-Fueling Section /

IGNITION SYSTEM (Pro 12 / Pro 10):

Spark Plug: NGK BPMR7A / NGK CMR7A
 Spark Plug Gap: 0.02 in. (0.5 mm)

TRENCHING ASSEMBLY

Gearbox Assy: 10:1 ratio, V-output shaft; internal lubrication
 Gearbox Lubricant: 0.5 fl. oz (15 ml); Manf./Type: KLUBERSYNTH GH 6-320
 Blades: 12 or 10 inch carbide tipped (standard)