

3 CCT SELECTABLE LED WALLPACK CUBE LR40605, LR40615

WARNING

1. TO AVOID ELECTRIC SHOCK, DISCONNECT POWER AT SOURCE PRIOR TO INSTALLATION.
2. THE INSTALLATION SHOULD BE PERFORMED BY QUALIFIED ELECTRICIANS OR LIGHTING TECHNICIANS.
3. BEFORE CONDUCTING ANY INSTALLATION, MAINTENANCE, OR REMOVAL, DISABLE ALL POWER TO THE LUMINAIRES AND WAIT UNTIL THE FIXTURE HAS COOLED DOWN.
4. DO NOT TOUCH THE FIXTURE WHILE IT IS IN USE.
5. IF THERE IS ANY PROBLEM WITH FIXTURE, DO NOT TURN OFF THE POWER AND DO NOT ATTEMPT TO REPAIR UNLESS YOU ARE A QUALIFIED ELECTRICIAN.
6. THE ELECTRICAL RATING OF THIS PRODUCT CONTAINS A PHOTOCELL WHICH IS 110-277VAC.
7. MOUNTING INSTRUCTIONS SPECIFY THE USE OF A SEALING COMPOUND TO FULLY FILL THE GAP OF THE FIXTURE AND MOUNTING SURFACE.
8. WALL MOUNT ONLY

INSTALLATION

JUNCTION BOX MOUNT

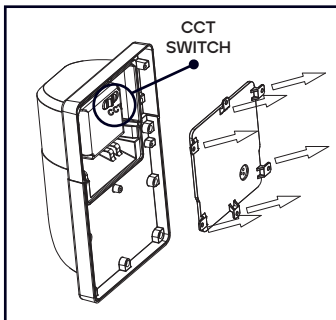

1. Loosen the 6 screws on the back cover of the fixture to open the back cover and adjust the CCT switch.

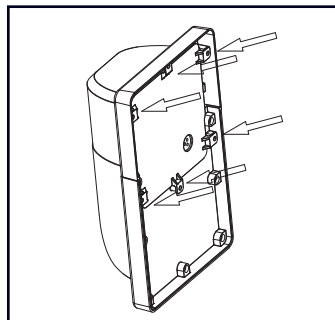

2. Fix the back cover with fixture by using the 6 screws.

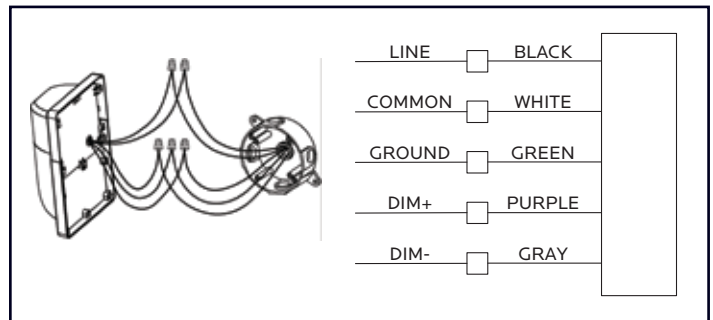

3. Make supply wire (power and dimming) to fixture wire connections as required thru splice access. Universal voltage driver allows operation at 110V thru 277V, 60 or 60Hz. 0-10V control wires must be rated for 300V minimum. For 0-10V dimming, refer to the above diagram.

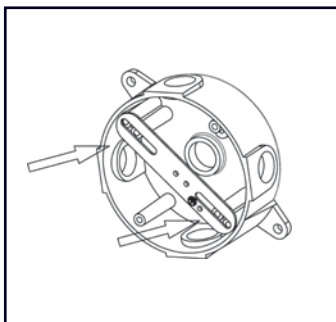

4. Install the bracket on the junction box with 2 screws.

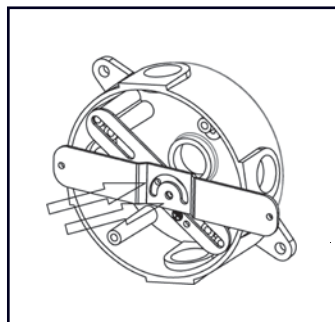

5. Use 2 screws to fix bracket after adjusting position.

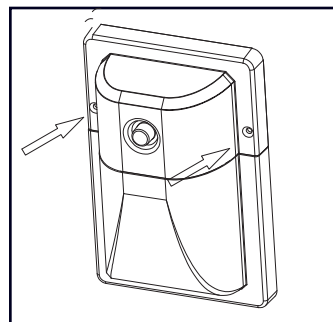

6. Attach the fixture to the bracket by using 2 sets of screws and washers.

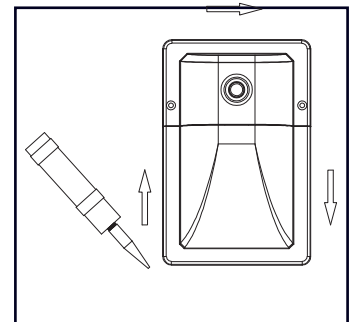

7. After the fixture is installed on the wall, fill the gap between the wall and the fixture with glue. (Only 3 mounting surfaces need to be filled)