

LED 3" UP/DOWN WALL SCONCE CUBE - 3 CCT SELECTABLE LR40343

PLEASE READ AND UNDERSTAND THIS INSTRUCTIONS BEFORE ATTEMPTING TO ASSEMBLE, OPERATE OR INSTALL THE PRODUCT.

WARNING

AVOID FIRE OR ELECTRIC SHOCK. THIS PRODUCT MUST BE INSTALLED IN ACCORDANCE WITH THE APPLICABLE INSTALLATION CODE BY A PERSON FAMILIAR WITH THE CONSTRUCTION AND OPERATION OF THE PRODUCT AND THE HAZARDS INVOLVED. BEFORE INSTALLING THE FIXTURE, ENSURE THAT ALL PARTS ARE PRESENT AND SAME AS THE PART LIST. IF ANY PART IS MISSING OR DAMAGED, DO NOT ATTEMPT TO ASSEMBLE, INSTALL OR OPERATE THIS FIXTURE. WALL MOUNT ONLY. MIN 75°C SUPPLY CONDUCTOR. SUITABLE FOR WET LOCATION.

CAUTION: TURN OFF POWER AT FUSE OR CIRCUIT BREAKER BOX BEFORE INSTALLATION AND MAINTENANCE TO AVOID ELECTRIC SHOCK. THIS FIXTURE REQUIRES A 120V AC POWER SOURCE. DO NOT CONNECT THIS FIXTURE TO A DIMMER OR TIMER. FIXTURE MUST BE INSTALLED ACCORDING TO THE NATIONAL ELECTRICAL CODE AND LOCAL BUILDING CODES. IF YOU ARE UNSURE ABOUT WIRING, CONSULT A QUALIFIED ELECTRICIAN.

THIS DEVICE COMPLIES WITH PART 15 OF THE FCCA RULES. OPERATION IS SUBJECT TO THE FOLLOWING TWO CONDITIONS: (1) THIS DEVICE MAY NOT CAUSE HARMFUL INTERFERENCE, AND (2) THIS DEVICE MUST ACCEPT ANY INTERFERENCE RECEIVED, INCLUDING THAT MAY CAUSE UNDESIRABLE OPERATION.

RETAIN THESE INSTRUCTIONS FOR FUTURE MAINTENANCE REFERENCE.

INSTRUCTIONS

STEP 1. PREPARING FOR INSTALLATION

- A. DISCONNECT ELECTRICAL POWER AT FUSE OR CIRCUIT BREAKER BOX BEFORE INSTALLING OR SERVICING ANY PART OF THIS FIXTURE.
- B. REMOVE FIXTURE FROM CARTON; REMOVE COMPONENTS FROM HARDWARE KIT.
- C. REMOVE THE MOUNTING BRACKET (4) FROM THE FIXTURE (1).
- D. INSTALL MOUNTING BRACKET (4) TO SHEET PLATE (5) BY TIGHTENING TWO SCREWS (6).
- E. INSTALL MOUNTING BRACKET (4) AND SHEET PLATE (5) TO JUNCTION BOX (NOT PROVIDED) BY TIGHTENING TWO SCREWS (2) TO SECURE THEM.

WIRING - ALL WIRING MUST TAKE PLACE INSIDE JUNCTION BOX (NOT INCLUDED)

STEP 2. WIRING FIXTURE

- A. MAKE ALL WIRE CONNECTIONS TO APPROPRIATE WIRE. SECURE WITH WIRE NUTS (PROVIDED).
- B. CONNECT THE BARE WIRE FROM THE FIXTURE AND THE SUPPLY POWER SOURCE GROUND WIRE.
- C. CONNECT THE BLACK WIRE FROM THE FIXTURE TO THE BLACK (L) WIRE FROM THE SUPPLY POWER SOURCE.
- D. CONNECT THE WHITE WIRE FROM THE FIXTURE TO THE WHITE (N) WIRE FROM THE SUPPLY POWER SOURCE.
- E. PULL ON EACH WIRE LEAD TO MAKE SURE CONNECTIONS ARE SECURE. MAKE SURE NO BARE WIRES ARE EXPOSED OUTSIDE OF WIRE CONNECTORS. TUCK ALL CONNECTIONS NEATLY INTO THE JUNCTION BOX.

*ADJUST CCT SWITCH ON THE BACK OF THE FIXTURE ACCORDING TO THE DESIRED COLOR TEMPERATURE AS SEEN IN FIG. 2

STEP 3. MOUNTING

- A. INSTALL FIXTURE (1) TO MOUNTING BRACKET (4) BY TIGHTENING TWO SCREWS (3) ON TOP AND BOTTOM TO SECURE AS SEEN IN FIG. 1
- B. AFTER MOUNTING THE FIXTURE, CAULK THE SURFACE BETWEEN THE FIXTURE BACK AND THE MOUNTING SURFACE.

STEP 4 - FOR WET APPLICATION

- A. Apply a small amount of silicone (not included), per manufacturer's recommendation, around the upper perimeter of the fixture (2) where it contacts with the surface of the wall but not the bottom.

STEP 5. RESTORE POWER AT FUSE OR CIRCUIT BREAKER BOX.

BOX CONTENTS

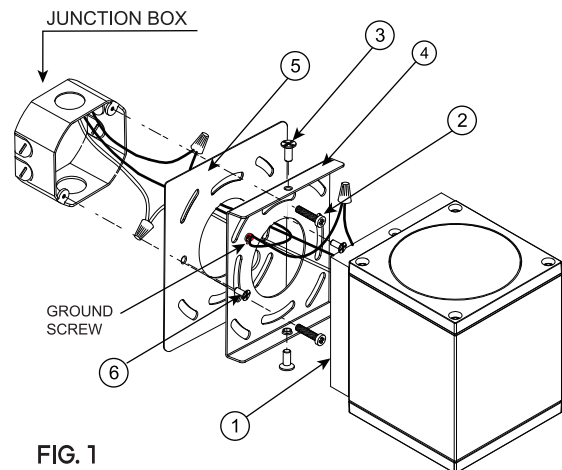
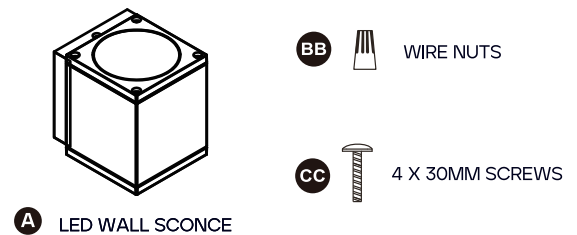

FIG. 1

FIG. 2

