

EMERGENCY LED BATTERY LR35127

LED/EMR/30W/UFO/100-347V
30W AC

EM LED BATTERY



UFO HIGHBAY



REMOTE CONTROL



LR35127
EMERGENCY
LED BATTERY

FEATURES

- Simple wiring: directly connect to AC INPUT of LED driver.
- Constant power output 30W/40W/60W.
- Universal input range, 100-347Vac, 50/60Hz.
- High output voltage DC 170V .
- Optimized design for UFO highbay fixture, private mold patent design.
- Built-in integrated junction box.
- Protection: over-voltage, short-circuit, over-load, open-circuit.
- Wireless remote control or non-remote control for emergency test are optional.
- UL Listed for field or factory installation.
- Comply with UL924 standard and CSA 22.2, No. 141 for USA and Canada.
- California Energy Commission (CEC) Title 20 with BC compliant.

SPECIFICATIONS

Input Voltage	100-347V AC 50/60Hz	Test switch/charging indicator light	Remote Control
Output Voltage	170V DC	Battery	Li-ion battery
Input Current	≤200mA	Charging time	≥24hours
Input Power	15W	Output power	30W
Emergency Time	90 minutes		
Warranty	5 Years	Weight	3.3kg
Ambient Temp	5°C-50°C	Dimensions	273.26 x Φ142.3mm

EMERGENCY LED BATTERY

LR35127

30W AC



IMPORTANT SAFEGUARDS

When using electrical equipment, basic safety precautions should always be followed including the following

PLEASE READ AND FOLLOW ALL SAFETY INSTRUCTIONS.

CAUTION: RISK OF SHOCK-disconnect emergency and normal input power sources before servicing.

ASSEMBLY and FIELD INSTALLATION WIRING: WARNING: AC power must be off before proceeding with assembly or installation of emergency driver.

IMPORTANT: An unswitched AC power source is required (100-347 VAC, 50/60 Hz).

This device is designed for fixtures listed for dry, damp or wet locations.

IMPORTANT: Customers are advised to charge emergency LED driver 24 hours every 6 months during storage.

IMPORTANT: For LED/EMR/30W/UFO/100-347V suggested to use for LED lamp less than 200W (when dimming to minimum the power needs to be less than 25W).

For LED/EMR/40W/UFO/100-347V suggested to use for LED lamp less than 300W (when dimming to minimum the power needs to be less than 35W).

IMPORTANT: Make sure all connections are in accordance with the National Electrical Code or Canadian Electrical Code and any local regulations.

CAUTION: To reduce the risk of electric shock disconnect both normal and emergency sources within this unit before servicing any equipment connected to this unit.

CAUTION: Do not mount near gas or electric heaters.

CAUTION: Equipment should be mounted in locations and at heights where it will not be subjected to tampering by unauthorized personnel.

CAUTION: The use of accessory equipment not recommended by the manufacturer may cause an unsafe condition.

CAUTION: Do not use this equipment for other than its intended use.

CAUTION: Use with grounded, UL Listed, dry or damp location rated fixtures. Case should also be grounded.

CAUTION: This product is for use in indoor fixtures only. Do NOT use near heated air handling outlets or hazardous locations.

Suitable for use in 5°C -50°C ambient temperatures. Max. mounting height: 48.65ft.

CAUTION: Battery is rechargeable Li-ion type and must be recycled or disposed of properly.

Do not use this emergency driver with accessory equipment other than recommended by the manufacturer.

Failure to follow this may cause an unsafe condition and will void warranty.

Servicing of this equipment should be performed by qualified personnel only.

IMPORTANT: Illuminated Indicator (LED light) means battery is in charge mode when AC power is applied.

It is recommended and required by applicable code to test emergency function to ensure proper operation of the system; press the remote controller ON button every 30 days to ensure the emergency driver is functioning and LED light source is illuminated. Conduct a ninety minute (90) discharge test one time (1) per year.

LED light source should be illuminated for a minimum of ninety minutes (90).

TESTING SYSTEM: The emergency battery requires a minimum charge of one (1) hour before testing the circuit.

A full charge requires twenty four(24) hours.

WIRING DIAGRAM

1 WITH DIMMER

For UFO LED Highbay ≤ 300W and have 0-10V dimming function

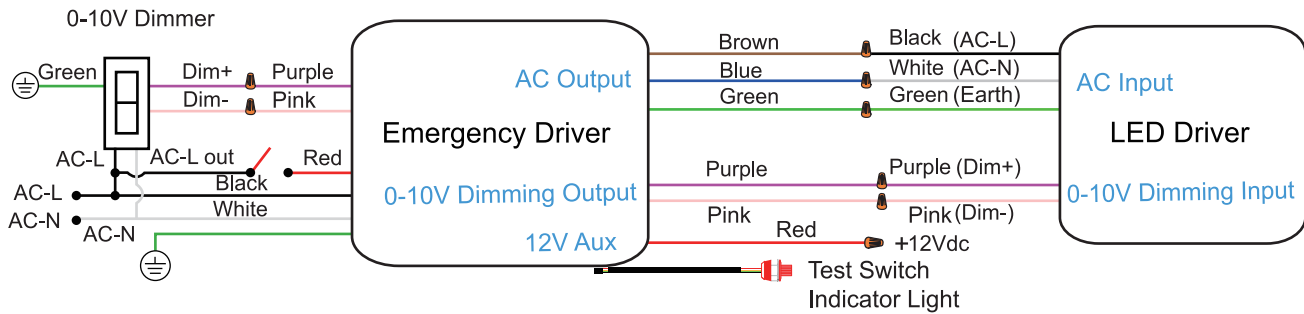

IMPORTANT

Emergency driver 0-10V dimming wires must be connected to UFO LED driver dimming wires for EM to function properly. will NOT operate if not connected.

RECOMMENDATION:

Emergency Output Power ≥ 20% Output Power of UFO LED High Bay

2 WITH WALL SWITCH (WITHOUT DIMMER)

For UFO LED Highbay ≤ 300W and have 0-10V dimming function

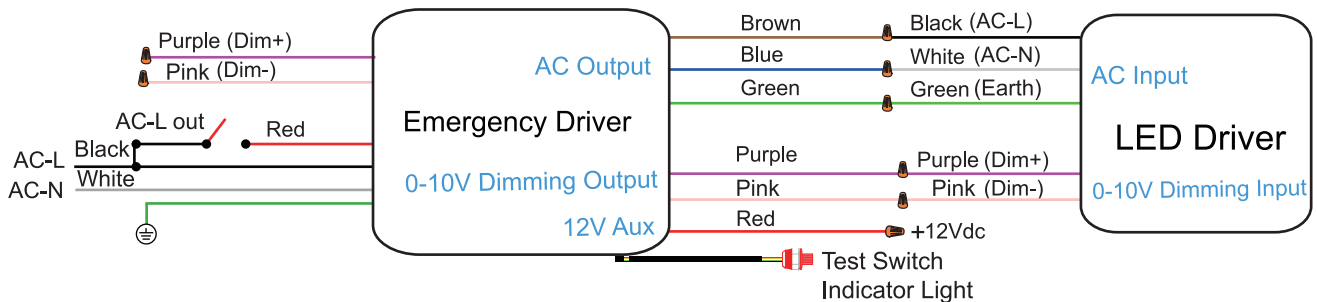

IMPORTANT

Emergency driver 0-10V dimming wires must be connected to UFO LED driver dimming wires for EM to function properly. will NOT operate if not connected.

RECOMMENDATION:

Emergency Output Power ≥ 20% Output Power of UFO LED High Bay

3 WITHOUT WALL SWITCH & DIMMER, 24Hr LIGHTING

For UFO LED Highbay ≤ 300W and have 0-10V dimming function

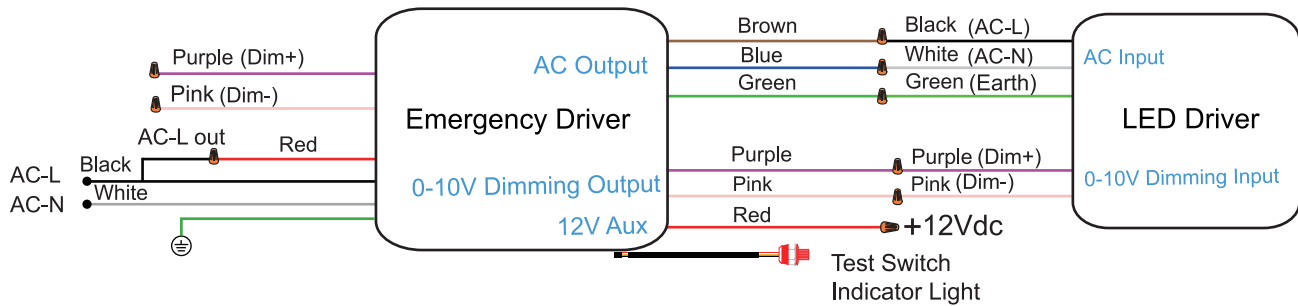

IMPORTANT

Emergency driver 0-10V dimming wires must be connected to UFO LED driver dimming wires for EM to function properly. will NOT operate if not connected.

RECOMMENDATION:

Emergency Output Power ≥ 20% Output Power of UFO LED High Bay

4 WITH SENSOR (100-277/347V AC)

For UFO LED Highbay ≤ 300W and have 0-10V dimming function

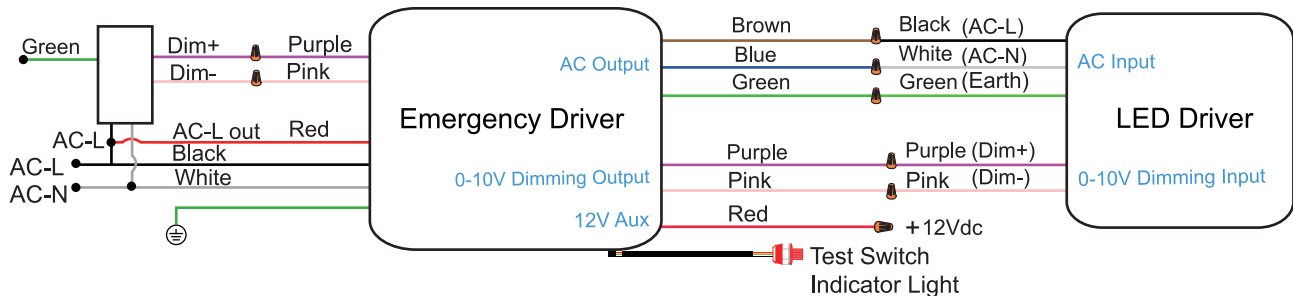

IMPORTANT

Emergency driver 0-10V dimming wires must be connected to UFO LED driver dimming wires for EM to function properly. will NOT operate if not connected.

RECOMMENDATION:

Emergency Output Power ≥ 20% Output Power of UFO LED High Bay

WIRING DIAGRAM

5 WITH 12VDC SENSOR (The current is less than 30mA)

For UFO LED Highbay ≤ 300W and have 0-10V dimming function

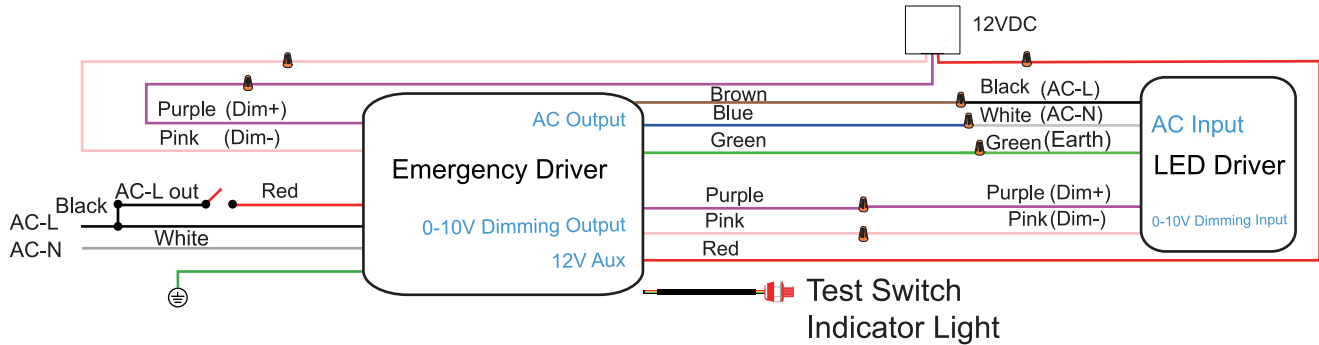

IMPORTANT

Emergency driver 0-10V dimming wires must be connected to UFO LED driver dimming wires for EM to function properly. will NOT operate if not connected.

RECOMMENDATION:

Emergency Output Power ≥ 20% Output Power of UFO LED High Bay

INSTALLATION STEPS



CAUTION: MAKE SURE THE AC POWER IS OFF BEFORE INSTALLING

STEP 1: NOTICE

- (A): Disconnect all power sources to the lighting fixture and ensure they are locked out during installation and maintenance.
- (B): Select a suitable location on the ceiling for proper mounting of LED emergency driver (battery).

STEP 2: INSTALLATION

- (A) Install the ring bolt to the top thread hole of LED emergency driver and fix it with screw.
- (B) Install M10-rod or ring bolt or G-hook to the Bottom thread hole of LED emergency driver and fix it with screw.
- (C) Install the LED emergency driver to UFO highbay fixture with screw.
- (D): Open the LED emergency cover and remove the plastic covers and install the waterproof connectors (4pcs).

STEP 3: WIRING

Pull all wires through the waterproof connectors into the cavity of emergency driver.

- (A): Connect the AC output wires (Brown, Blue and Green) of emergency driver with AC input wires of LED highbay fixtures.
- (B): Connect the dimming output wires (Purple and Pink) of emergency driver with the dimming input wires of LED Driver.
- (C): Connect AC input wires (Black, White and Red) of emergency driver with AC main power cord.
- (D): Connect the input dimming wires (Purple, Pink) of emergency driver with dimming wires from dimmer.
- (E): Close and lock emergency driver and secure shut using screw.

Make sure all connections are in accordance with manufacturer's installation details.

OPERATION INSTRUCTIONS TYPICAL INSTRUCTIONS

CHAIN OR CABLE MOUNT

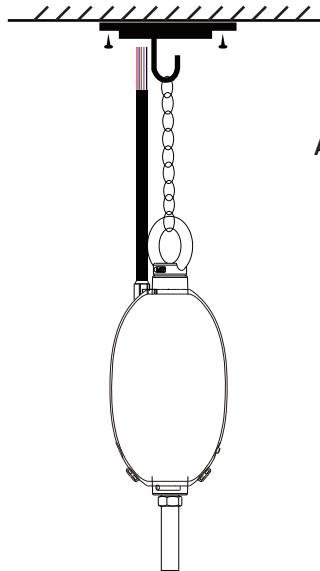

ACCESSORIES

RING BOLT
*INCLUDED

**OPTIONAL
G-HOOK**
*SOLD
SEPARATELY

*See instruction manual for typical installation and select appropriate mounting method

INSTRUCTIONS FOR REMOTE CONTROL

- ON** Press the ON button to test emergency function. this light will switch to its emergency lighting mode and the indicator light will turn off.
- OFF** Press the OFF button, the light will revert to normal lighting mode.
When main power supply is OFF (emergency mode), press the off button to turn off emergency function.

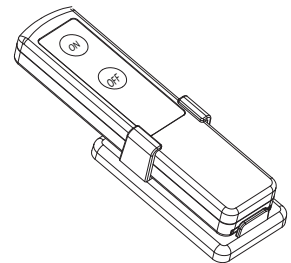

TEST SWITCH & INDICATOR

RED ON: Charging mode

RED OFF: Discharging mode

Note: remote controller must be pointed at the indicator light and be within 45degree angle to receive signal.

Remote controller needs two AAA batteries to operate(not included in unit)

DIMENSIONS

