

4' T5 RETROFIT TUBE

LR34156, LR34157, LR34158, LR34159

NOTE:

- RISK OF FIRE OR ELECTRIC SHOCK - Please read and understand the detailed installation instructions before installing the LED T5 tube light.
- If the tube is installed as Type B, the luminaire, once modified as a retrofit fixture will no longer operate fluorescent lamps.
- LED T5 tube lights are designed to work with electronic/magnetic ballast (Check the ballast compatibility list) or work with AC direct wire double-end power input.
- DO NOT use where directly exposed to water or weather. Non-submergible (not water tight).
- Use in dry or damp locations only.
- NOT suitable for use with dimmers.
- Disable all power to the fixture before inspection, installation, or removal. Failure to do so will create a hazardous and fatal working environment.
- DO NOT open - No user serviceable parts inside.

WARNING:

- a. **RISK OF FIRE OR ELECTRIC SHOCK.** LED retrofit kit installation requires knowledge of luminaires electrical systems. If not qualified, DO NOT attempt installation. Contact a qualified electrician.
- b. **RISK OF FIRE OR ELECTRIC SHOCK.** Install this kit only in the luminaires that have the construction features and dimensions shown in the photographs and/or drawings and where the input rating of the retrofit kit does not exceed the input rating of the luminaire.
- c. **DO NOT** make or alter any open holes in an enclosure of wiring or electrical components during kit installation.
- d. To prevent wiring damage or abrasion, DO NOT expose wiring to edges of sheet metal or other sharp objects.
- e. Installers should not disconnect existing wires from lamp holder terminals to make new connections at lamp holder terminals. Instead installers should cut existing lamp holder leads away from the lamp holder and make new electrical connections to lamp holder lead wires by employing applicable connectors.
- f. For a linear tubular LED lamp conversion, there shall be text or a diagram showing how the supply connections were made to the lampholders so the correct connections will be made to the lamp when the lamp is installed or replaced.
- g. This retrofit kit accepted as a component of a luminaire where the suitability of the combination shall be determined by authorities having JURISDICTION.

TYPE A - ASSEMBLY INTRODUCTION

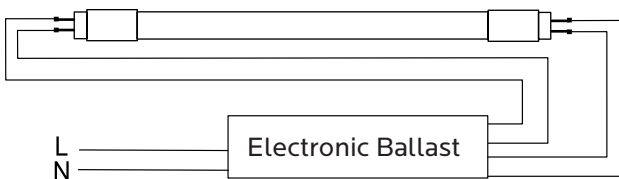

TYPE A - INSTALLATION GUIDE

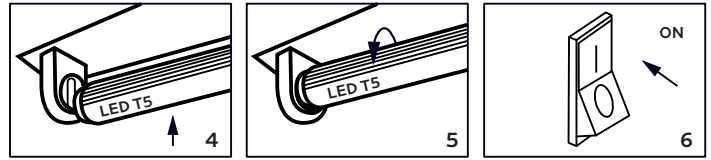
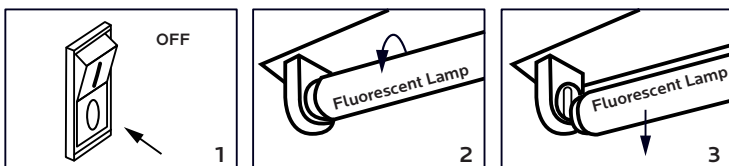

INSTRUCTIONS:

1. Switch-off power to the luminaire
2. Remove diffuser (if provided).
3. Remove the existing fluorescent lamps from the luminaire
4. Install the LED tube lamp
5. Install diffuser (if removed in step 2)
6. Switch on power to the luminaire.
7. Before installation, check specifications for the most current ballast compatibility list. If not compatible, insert LED tubes according to Type B installation instructions.

TYPE B - ASSEMBLY INTRODUCTION

NOTE: The tube can work with double-end power input only.

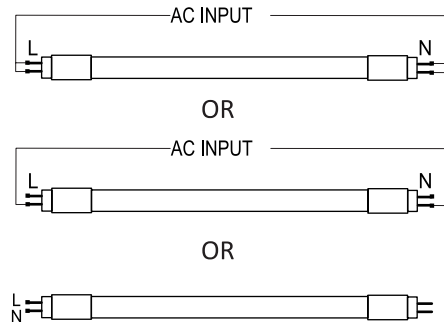

TYPE B - INSTALLATION GUIDE

INSTRUCTIONS:

1. DISCONNECT POWER TO LUMINAIRE

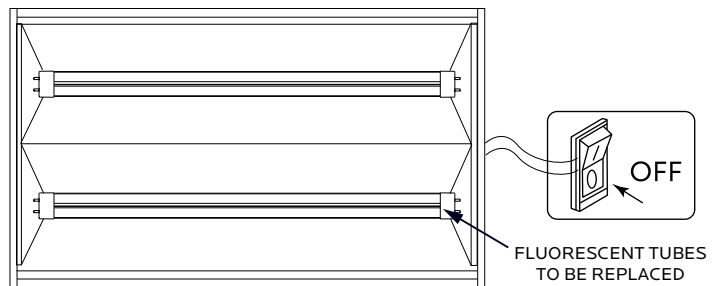

Disconnect power to luminaire or circuit (if possible). Ensure all power is OFF by using a voltmeter or other approved method to confirm.

2. REMOVE EXISTING TUBE LAMP(S)

- a. Remove troffer lens, if present.
- b. Remove existing fluorescent tube by rotating one-quarter turn and sliding lamp(s).

c. Remove ballast cover. (Cover may be secured with screws or tabs).

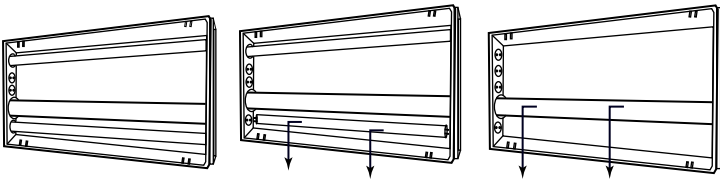

3. a. RETROFIT LUMINARE

- Retrofit luminaire with one lamp and one electronic ballast. Disconnect the wires between ballast according to the figure below.

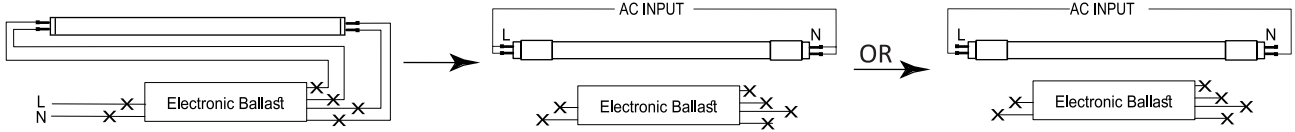

b. RETROFIT LUMINARE

- Retrofit luminaire with two lamps and one electronic ballast. Disconnect the wires between ballast according to the figure below.

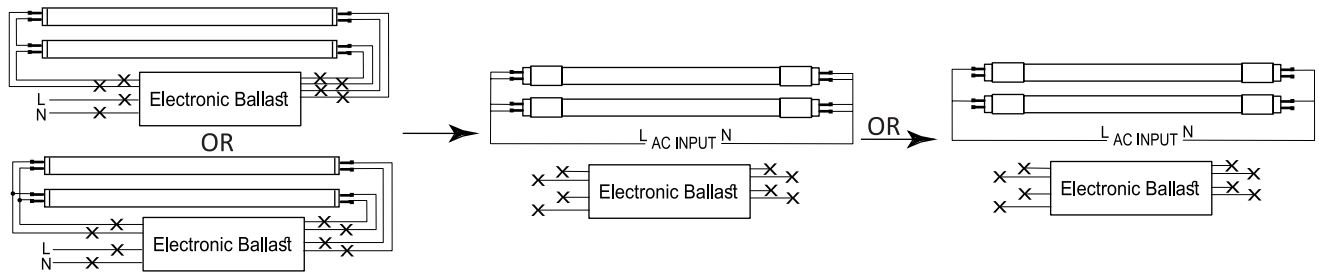

c. RETROFIT LUMINARE

- Retrofit luminaire with three lamps and one electronic ballast. Disconnect the wires between ballast according to the figure below.

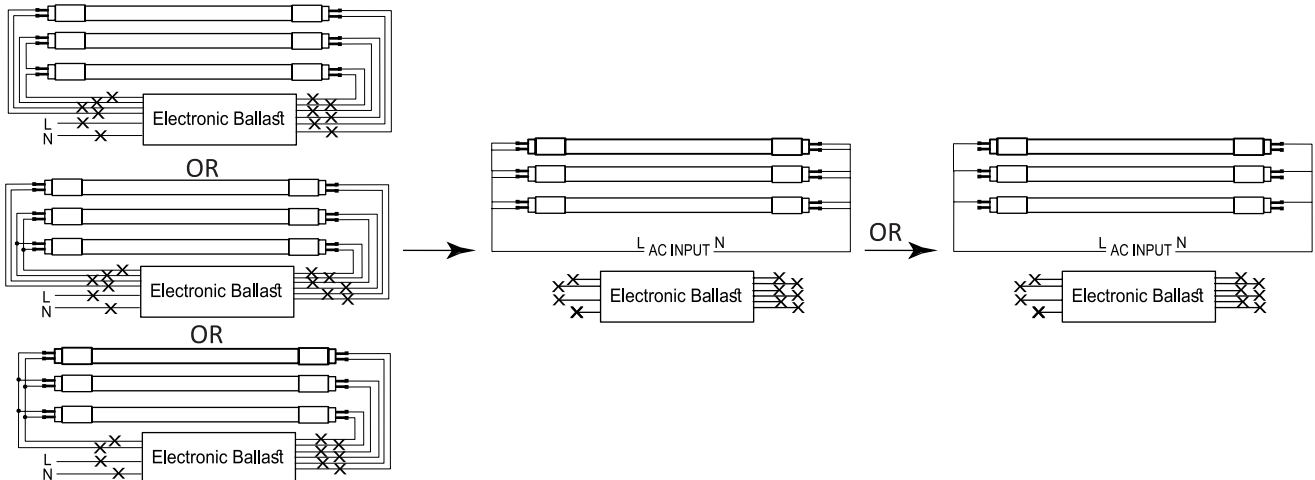

d. RETROFIT LUMINAIRE

- Retrofit luminaire with four lamps and one electronic ballast. Disconnect the wires between ballast according to the figure below.

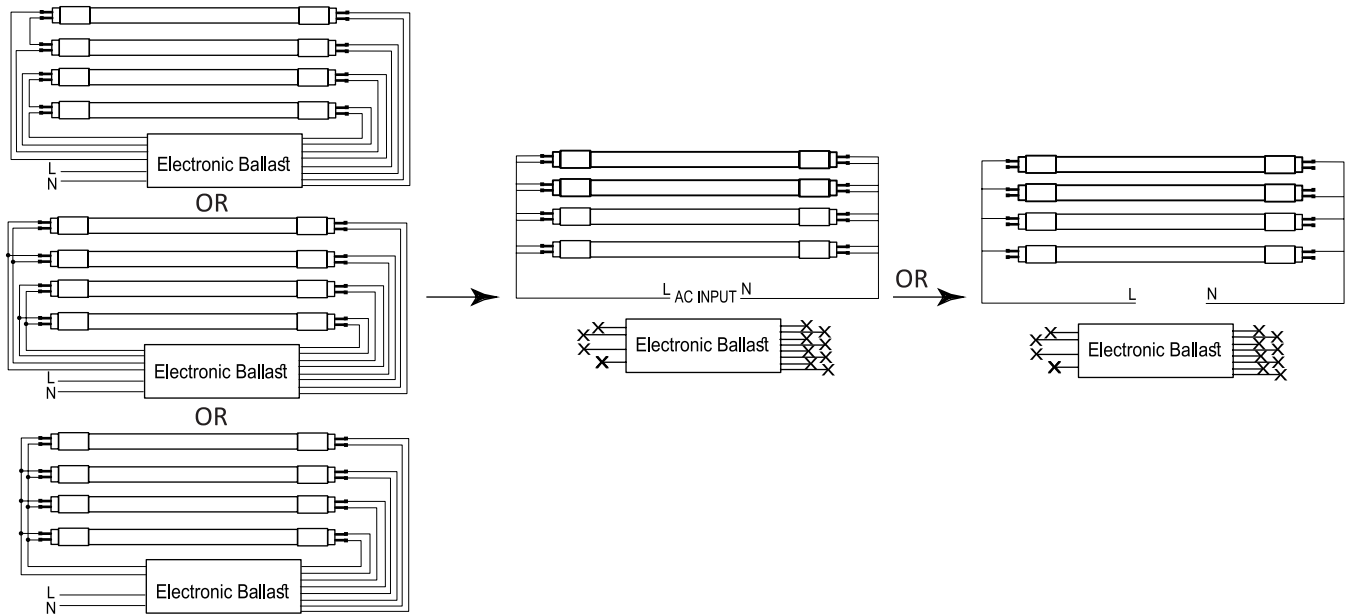

4. INSERT LED TUBES

- Ensure both the ends of the LED tube are aligned with socket, then insert LED lamp in the normal way by sliding pins into sockets and rotating quarter turn until the LED tube locks in place.
- LED lamps are now fully installed.
- Replace troffer lens, if present.
- After modification completed, attach the replacement marking and cautionary label to a visible place on the luminaire and keep it visible after installation.

5. RESTORE THE POWER OF LUMINAIRE.

Restore power to circuit/luminaire and test light. If necessary, adjust position of LED tube, and enjoy your new LED tube.

BALLAST COMPATIBILITY LIST	
BRAND	MODEL
PHILLIPS ADVANCE	ICN-2S54-T
PHILLIPS ADVANCE	ICN-2S54-N
PHILLIPS ADVANCE	ICN-2S54-90C-N
PHILLIPS ADVANCE	ICN-2S54-90C-T
PHILLIPS ADVANCE	ICN-4S54-90C-2LS-G
PHILLIPS ADVANCE	HCN-2S54-90C-WL
GE	GE254MVPS90-A-L
GE	GE254MVPS-D-1
GE	GE454PS347/480-E
ESPEN	VE454MVHRP T1088
ESPEN	VE254MVHRP11101
OSRAM	QTP 2X54T5HO/347-480 PSN HT
UNIVERSAL	B454PUNV-E
KEYSTONE	KTEB-113-1-TP-SN-MB/A