

1X4, 2X2, 2X4 LED CCT & WATTAGE SELECTABLE TROFFER LR25135, LR25136, LR25137

PLEASE read these instructions carefully before installation and keep for reference.

WARNINGS

- WARNING - Risk of electric shock. Do not open or remove covers
- WARNING - Refer servicing to qualified service personnel
- DISCONNECT POWER BEFORE REPAIRS AND MAINTENANCE
- WARNING - Risk of electric shock. Use in dry or damp locations only
- WARNING - Risk of electric shock. Not for use where exposed to weather

IMPORTANT

- Read instructions carefully before installation.
- Keep these instructions for future reference.
- The troffer must be wired in accordance with the National Electrical Code and all applicable local codes.
- Proper grounding is required for safety.
- This product must be installed in accordance with the applicable installation code by a qualified electrician who is familiar with the construction and operation of the product and the hazards involved.

CAUTION

- Inherently protected
 - Access above ceiling required
 - Suitable for damp location use
 - This product must be installed in accordance with the applicable installation code by a person familiar with the construction and operation of the product and the hazard involved.
 - Suitable for operation in ambient not exceeding 104°F
 - Do not press the diffuser with your fingers (when installing the troffer).
- RISK OF FIRE OR ELECTRIC SHOCK. THE TROFFER INSTALLATION REQUIRES KNOWLEDGE OF LUMINAIRES AND ELECTRICAL SYSTEMS. IF NOT QUALIFIED, DO NOT ATTEMPT INSTALLATION. CONTACT A QUALIFIED ELECTRICIAN.
 - TURN OFF ELECTRICAL POWER AT FUSE OR CIRCUIT BREAKER BOX BEFORE WIRING FIXTURE TO THE POWER SUPPLY.
 - TURN OFF THE POWER WHEN YOU PERFORM ANY MAINTENANCE.

RECESSED INSTALLATION

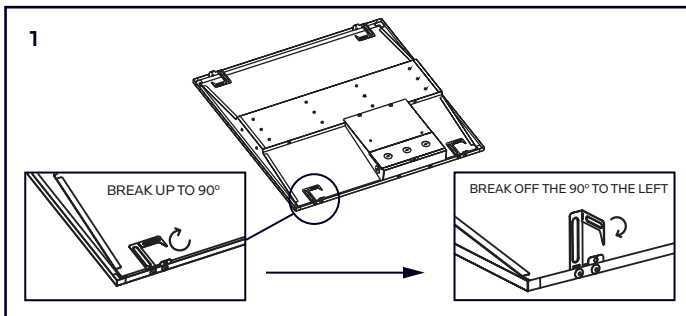

1. Remove the original ceiling tile for the Troffer.

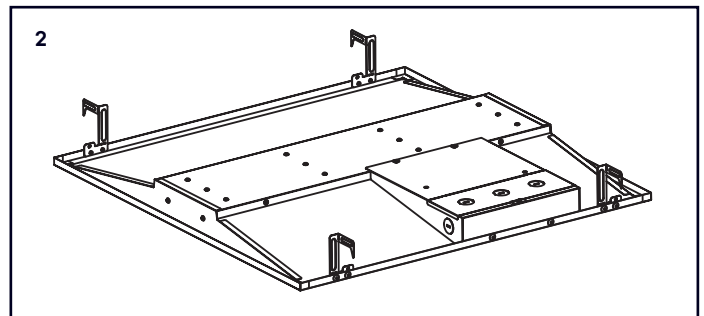

2. Turn off the electrical power then connect with L/N/GND wire leads.

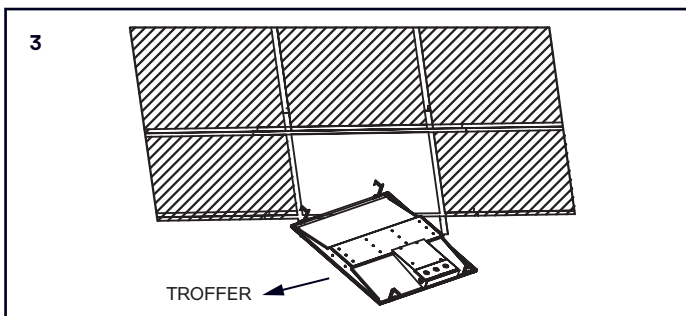

3. Use the protective brackets for safety.

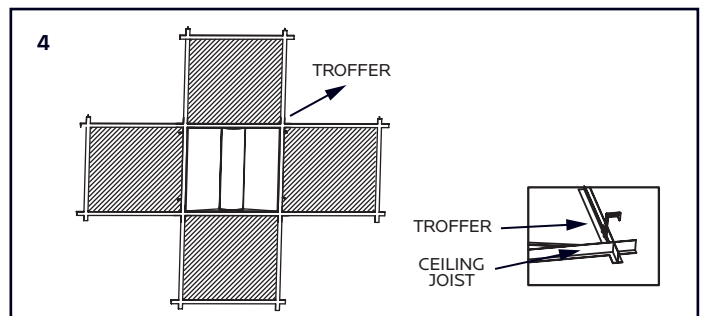

4. Adjust appropriate location in the T bar

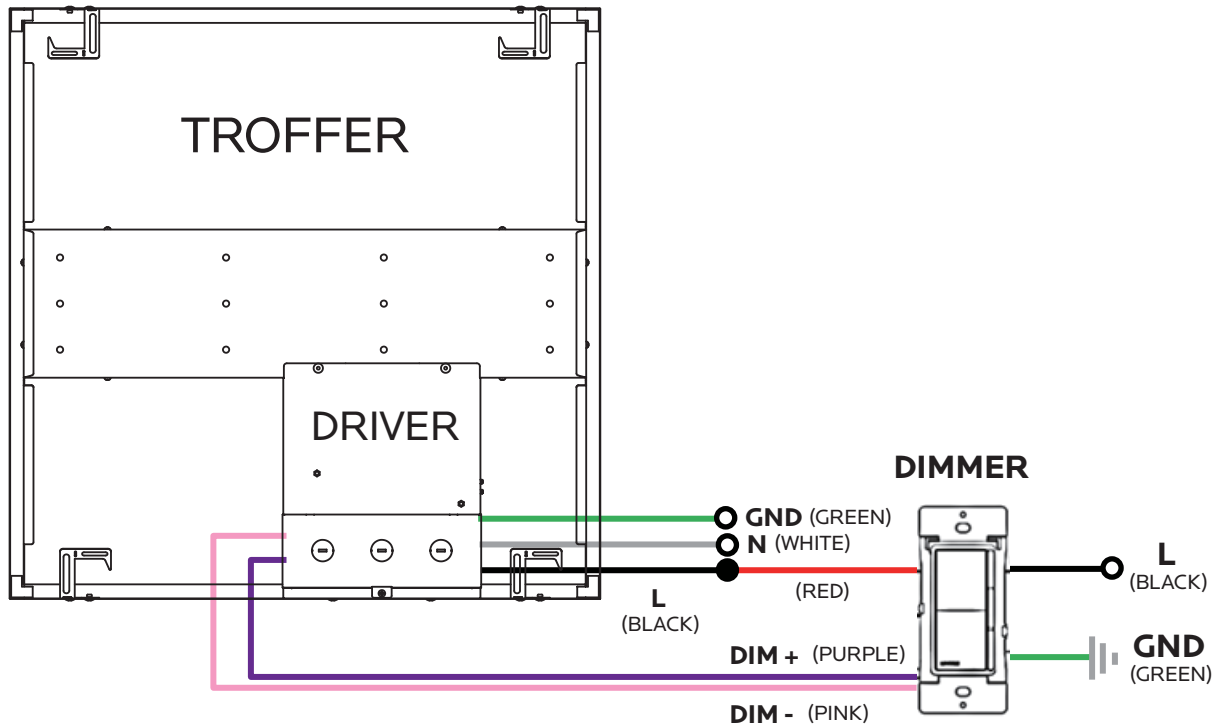

CCT & POWER SWITCH

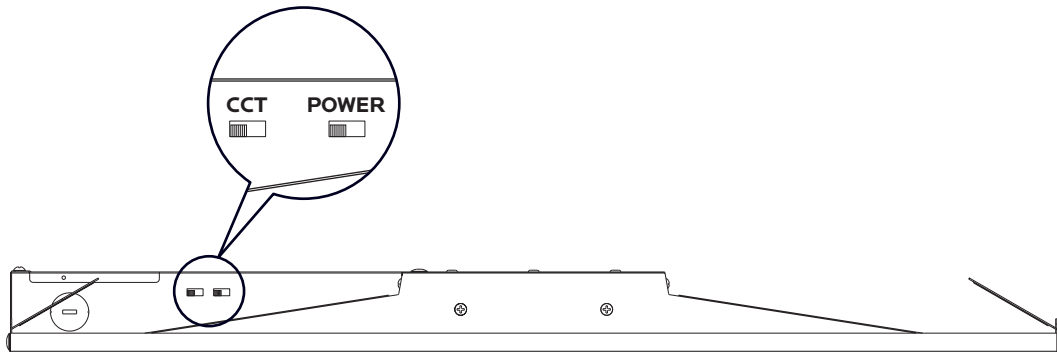

1X4 TROFFER	
3500K <input type="checkbox"/>	16W <input type="checkbox"/>
4000K <input type="checkbox"/>	20W <input type="checkbox"/>
5000K <input type="checkbox"/>	30W <input type="checkbox"/>

2X2 TROFFER	
3500K <input type="checkbox"/>	20W <input type="checkbox"/>
4000K <input type="checkbox"/>	30W <input type="checkbox"/>
5000K <input type="checkbox"/>	40W <input type="checkbox"/>

2X4 TROFFER	
3500K <input type="checkbox"/>	30W <input type="checkbox"/>
4000K <input type="checkbox"/>	40W <input type="checkbox"/>
5000K <input type="checkbox"/>	50W <input type="checkbox"/>