

## 6" LED DISK LIGHT - 5 CCT SELECTABLE LR23870, LR23871, LR23872, LR23873

### WARNING

RISK OF FIRE SUPPLY CONDUCTORS (POWER WIRES) CONNECTING THE FIXTURE MUST BE RATED MINIMUM 90°C. IF UNCERTAIN, CONSULT AN ELECTRICIAN.  
RISK OF ELECTRIC SHOCK DISCONNECT POWER AT FUSE OR CIRCUIT BREAKER BEFORE INSTALLING OR SERVICING.  
RISK OF FIRE/ELECTRIC SHOCK IF NOT QUALIFIED, CONSULT AN ELECTRICIAN.

### CAUTION

1. FOR YOUR SAFETY READ AND UNDERSTAND INSTRUCTIONS COMPLETELY BEFORE STARTING INSTALLATION.
2. THESE LUMINAIRES (FIXTURES) ARE DESIGNED TO MEET THE LATEST NEC REQUIREMENTS AND ARE LISTED IN FULL COMPLIANCE WITH UL 1598.
3. BEFORE ATTEMPTING INSTALLATION, CHECK YOUR LOCAL ELECTRICAL CODE, AS IT SETS THE WIRING STANDARDS FOR YOUR LOCALITY.

### INSTALLATION ONTO OUTLET BOX

1. Twist lens cover counter-clockwise to remove from Disk Light.
2. Attach the fixture to the outlet box by fastening supplied 1 1/2" outlet box screws through canopy keyholes. Make sure Disk Light is flush to the ceiling. (FIG. 1)
3. Replace the lens back on to the Disk Light by reversing step 1.

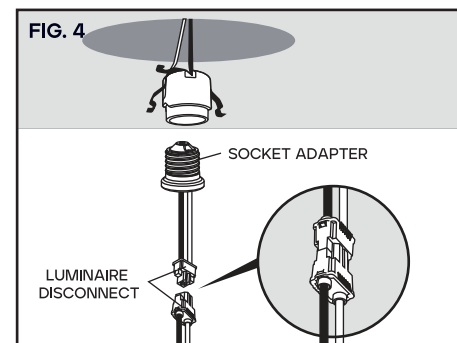
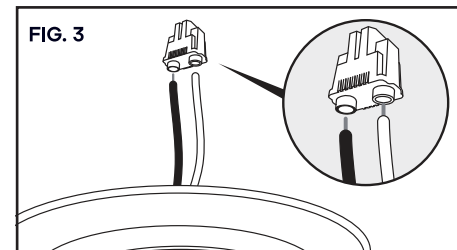
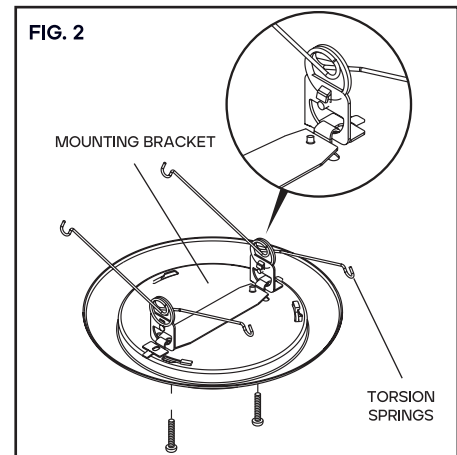
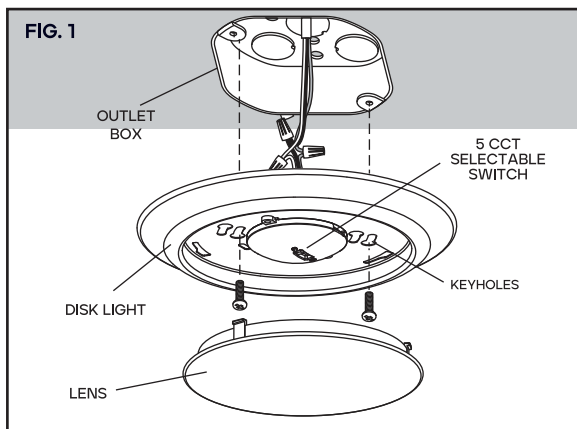

### ELECTRICAL CONNECTION

1. Provide electrical service according to the "National Electrical Code" or your local electrical code to the outlet box.
2. Connect supply wires to fixture wires and insulate with proper size wire nuts (FIG. 2)
  - a) Connect incoming ground wire (green or bare) to fixture ground wire (green or bare).
  - b) Connect incoming common (white) wire to fixture common (white).
  - c) Connect incoming hot (typically black) wire to fixture black wire.

### INSTALLATION INTO 5" & 6" RECESSED HOUSING

1. Insert torsion springs on to the mounting bracket. Make sure that the tab on the clips is positioned inwards.
2. Attach mounting bracket to Disk Light keyholes with supplied 1/4" screws (FIG. 2)
3. Detach the 2 halves of the luminaire disconnect, insert black and white wires of fixture into non-wired half of luminaire disconnect following colour code marked on connector. (FIG. 3)
4. Screw the socket adapter to socket in housing. (FIG. 4)
5. Plug the female connector of the Disk Light onto the male connector of the socket adapter assembly. (FIG. 4)
6. Install torsion spring of Disk Light to the spring retainer inside the housing.
7. Tuck all wires into the housing and carefully push the Disk Light into housing.

### CCT SELECTABLE SWITCH

#### CAUTION: TURN OFF POWER BEFORE SETTING COLOR TEMPERATURE

Choose color temperature using switch on the front of the fixture before installing.

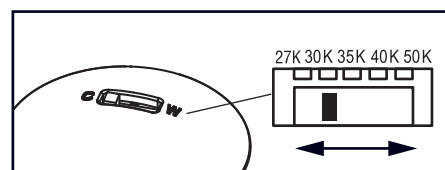

5 CCT SWITCH