

LED SURFACE MOUNT DOUBLE RING - CHROME EMERGENCY + BI-LEVEL MOTION SENSOR 12", 14", 16"

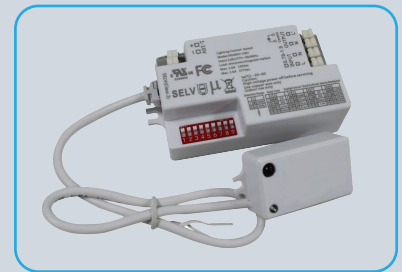

LR25190 - MOTION SENSOR



LR35120 - EM LED DRIVER

**CRI
80**

COLOR SELECTABLE

2700K 3000K 3500K 4000K 5000K

DIMMABLE

0-10V

**DAMP
LOCATION
RATED**

**5
YEAR
WARRANTY**

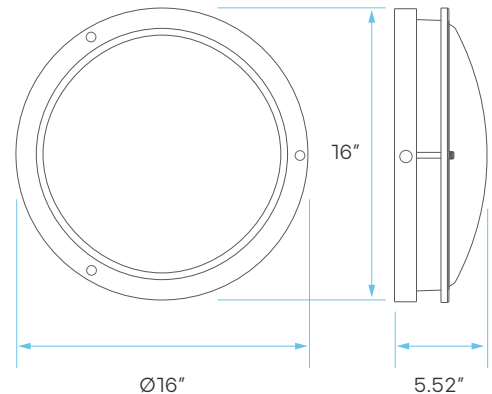
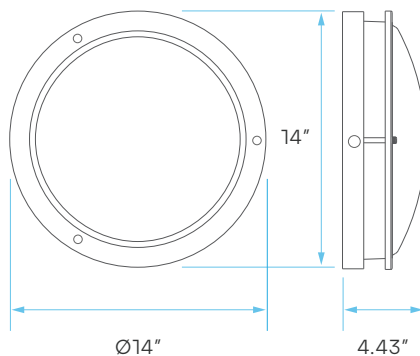
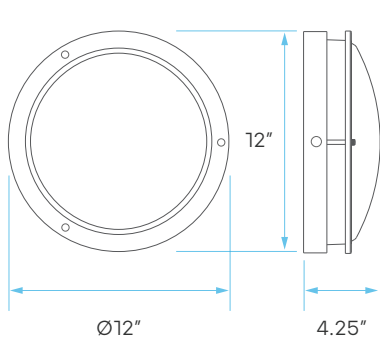

ELECTRICAL

	MODEL	DESCRIPTION	POWER	INPUT VOLTS	EFFICACY	LIFETIME	COST/YR
12"	LR23286+EM+MS	LED12"FLUSH/CHROME/5CCT+EM+MS	14	120-277V	77	50,000	\$ 2.17
14"	LR23287+EM+MS	LED14"FLUSH/CHROME/5CCT+EM+MS	18	120-277V	75	50,000	\$ 2.65
16"	LR23288+EM+MS	LED16"FLUSH/CHROME/5CCT+EM+MS	24	120-277V	75	50,000	\$ 3.13

PHOTOMETRIC

MODEL	DESCRIPTION	COLOR (CCT)	TEMP	LUMEN	FLOOD	CRI	ETL
LR23286+EM+MS	LED12"FLUSH/CHROME/5CCT+EM+MS	2700K/3000K/3500K/4000K/5000K	CCT SELECT	1120	120°	80	YES
LR23287+EM+MS	LED14"FLUSH/CHROME/5CCT+EM+MS	2700K/3000K/3500K/4000K/5000K	CCT SELECT	1440	120°	80	YES
LR23288+EM+MS	LED16"FLUSH/CHROME/5CCT+EM+MS	2700K/3000K/3500K/4000K/5000K	CCT SELECT	1920	120°	80	YES

EMERGENCY LED DRIVER 8-15W LR35120, LR35121



FEATURES

- Meets most of safety standards for lighting
- Standard CSA C22.2 NO. 141, UL924
- External lithium battery
- Battery protection: Overcharge protection, over discharge protection, short circuit protection.
- Indicator shows a variety of working modes
- The batteries Meet 500 cycles of standard CH and standard DCH
- RoHS compliant
- Emergency 1.5 Hrs

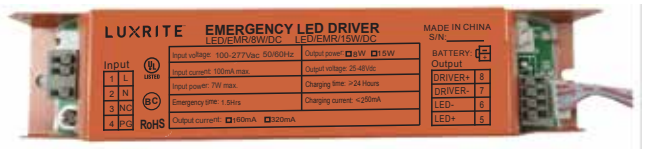

LED/EMR/8W/DC

LED/EMR/15W/DC

SPECIFICATIONS

Universal Input Voltage	100-277VAC, 50/60Hz
AC Input Current	100mA max
AC Input Power Rating	7.0W max
Output Current and Voltage	160-320mA 25-48Vdc
Output Power	8W/15W
Emergency Time	≥ 90 mins
Full Warranty	5 Years
Test Switch Indicator Light	Illuminated Test Switch, indicator light
Battery	Li-ion battery 7.4V/2500mAh Li-ion battery 14.8V/2000mAh
Battery Charging Current	250mA
Recharge Time	≥ 24 Hours
Temperature Rating (Ambient)	Li-ion 0°C to 40°C (32°F to 104°F)
Dimensions	7.4"x1.5"x1.1" (188mmx38mmx29mm)

WIRING

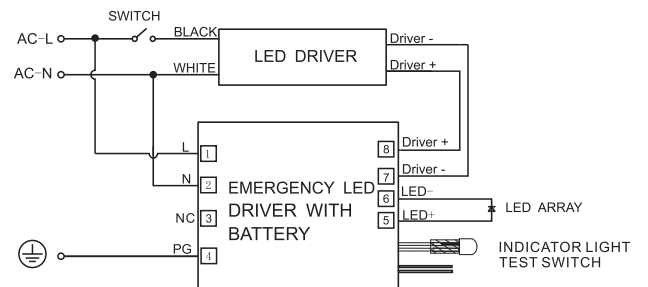

1. DO NOT MATE CONNECTOR UNTIL INSTALLATION IS COMPLETE AND AC POWER IS SUPPLIED.
2. TEST ACCESSORY LEADS-OBSERVE PROPER POLARITY WIRING.

DIMENSIONS

Li-ion battery 14.8V/2000mAh

Case: 7.4" x 1.5" x 1.14"
(Mounting center - 7.0")

Battery: 6.1" x 1.57"

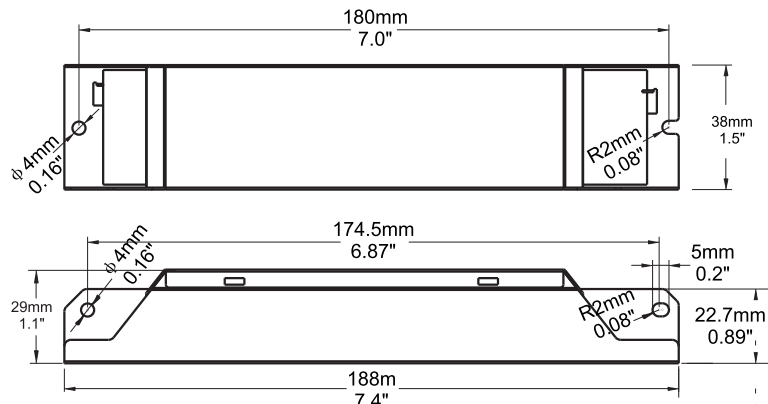

DIMENSIONS

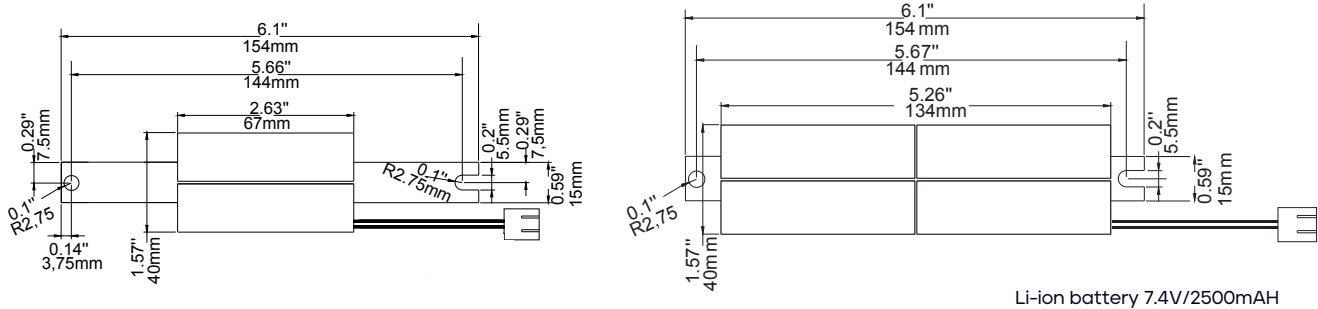

IMPORTANT SAFEGUARDS

When using electrical equipment, basic safety precautions should always be followed including the following:

READ AND FOLLOW ALL SAFETY INSTRUCTIONS

- **RISK OF FIRE OR ELECTRIC SHOCK** – Luminaire wiring and electrical parts may be damaged when drilling for installation of LED Emergency Backup. Check for enclosed wiring and components.
- **RISK OF FIRE OR ELECTRIC SHOCK** – This LED Emergency Backup installation requires knowledge of luminaires electrical systems. If not qualified, do not attempt installation. Contact a qualified electrician.
- Before installing, make certain the AC power to the fixture is off.
- The electrical rating of this product is 100-277VAC. Installer must confirm that there is 100-277VAC the fixture before installation.
- To prevent electrical shock, only mate unit connector after installation is complete and before the AC power to the fixture is back on.
- Do not use outdoors.
- This LED Emergency Backup unit requires an un-switched AC power source of 100-277VAC, 50/60Hz. The AC driver must be on the same branch circuit as the LED Emergency Backup unit.
- Do not let power supply cords touch hot surfaces.
- Do not mount near gas or electric heaters.
- Do not connect battery pack connector until all other wiring is complete and AC power is on.
- The emergency LED driver is for use with grounded, UL Listed LED luminaires, it shall be enclosed by the LED luminaire and bonded to the grounding of LED luminaire.
- Verify that all replacement lamp types marked on the installed luminaire are also identified as suitable for use with this emergency battery pack.
- The battery pack is fixed by the screw and the indicator lamp is attached to the shell of the luminaire by 3M tape.
- Equipment should be mounted in locations and at heights where it is not subject to tampering by unauthorized personnel.
- The use of accessory equipment is not recommended by the manufacturer and may cause an unsafe condition.
- Do not use this equipment for other than its intended use.
- Use with grounded, UL listed, dry or damp location rated fixture.

SAVE THESE INSTRUCTIONS

• APPLICATIONS

The BLD-AM15D-480600 emergency driver can be used with most LED loads that have a rated voltage of 25-48VDC. These emergency driver has been evaluated and found compliant to UL 924. The emergency pack assembly is accepted as a component of a luminaire where the suitability of the combination shall be determined by UL or Authorities Having Jurisdiction. The as-installed performance of the system must meet or exceed all Federal, State, and Local code requirements.

• OPERATION

AC OPERATION – AC power is present. The LED load from the LED driver is normal power supply, AC LED driver output current can not exceed 150W or 4A, the emergency driver is charging in a standby mode, the green LED light on to indicate that it is charging.

EMERGENCY OPERATION – When the AC power goes out, the emergency driver detects the AC power outage and automatically switch to the working emergency mode. The green LED light off. When the AC power is restored, the emergency driver backs to AC power working and starts re-charging, the green LED light is on.

LR25190 MICROWAVE SENSOR

1. Dual setting by DIP switch and remote control.
2. Suitable for Tri-Proof light.
3. Tri-Level control by 1-10V output.
4. Loop in and loop out for easy installation.
5. Sensitive and reliable
6. 8-15m High altitude installation.
7. 5 year limited warranty.

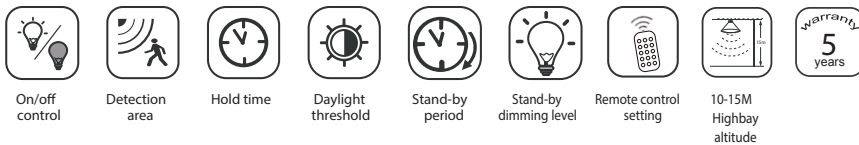

DETECTION COVERAGE

This figure indicates the maximum distance at the highest mounting height with 100% sensitivity.
Typical installation height 8-15m

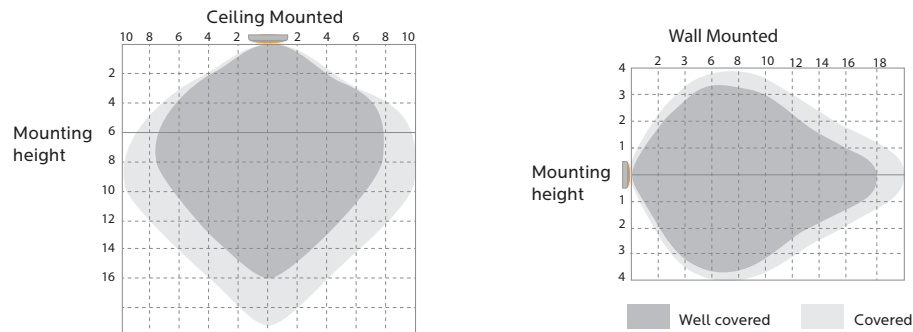

TECHNICAL DATA

Operating voltage	120-277VAC,50Hz/60Hz
Switching capacity	Max,3.0A@120Vac,50/60Hz; Max,2.0A@277Vac,50/60Hz
Stand-by power	≤1W
Control method	On/off / 1-10V Dimming Remote Control
Microwave frequency	5.8GHz±75MHz
Microwave power	<0.3mW
Detection area	50%/100%
Hold time	5s/30s/1min/10min
Daylight threshold	2Lux/10Lux/50Lux/Disable
Stand-by period	0s/30s/20min/+∞
Stand-by dimming level	10%/20%/30%/50%
Mounting height	8-15m /26.25-49.2ft
Detection range	Max.ø14m/45.93ft
Motion detection	0.5~1.5m/s
Operating temperature	-30°C~+70°C
IP rating	IP20
Warranty	5 years

MECHANICAL STRUCTURE

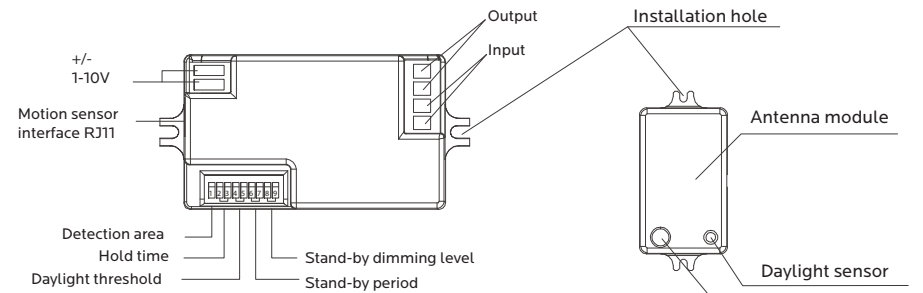

DIMENSIONS (UNIT: MM)

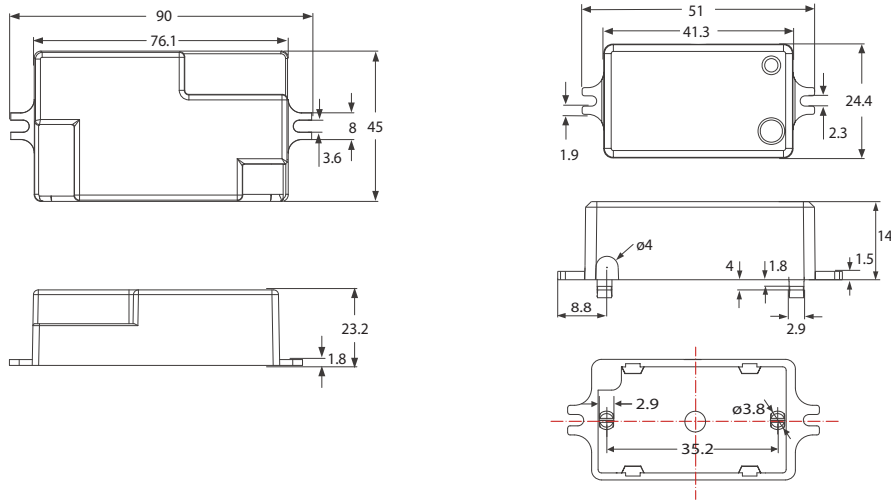

Note: Motion sensor setting and dimming setting please refer to remote control HD03R.
 HD02VRH Wire diameter 4mm, Standard Version Cable Length 48.5 cm (can be customized).

WIRING DIAGRAM

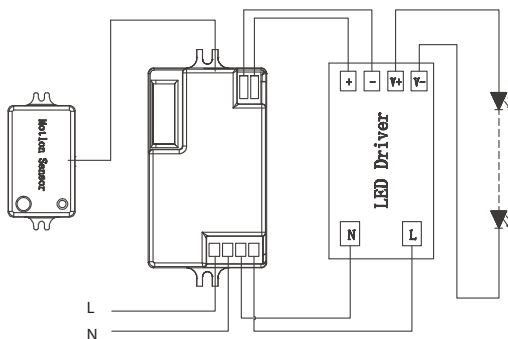

SETTINGS

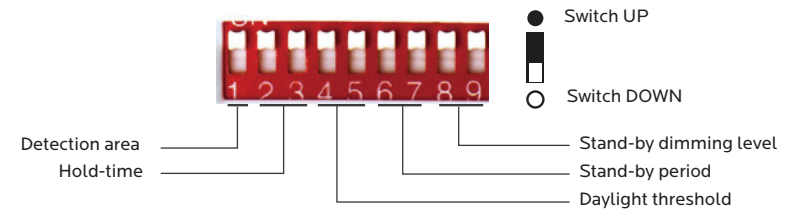

DETECTION AREA

●	100%
○	50%

In this area, movement will be detected and able to trigger the sensor. 100% detection area is also known as the strong sensitivity.

HOLD-TIME

●	●	5s
○	●	30s
●	○	1min
○	○	10min

The period of light keeping 100% brightness after moving objects leave the detection area.

DAYLIGHT TRESHOLD

●	●	Disable
○	●	50lux
●	○	10lux
○	○	2lux

Definition of the ambient brightness; only when the ambient brightness is lower than the preset specific lux amount, the sensor will work; when it's preset as "disable", the sensor works everytime it detects motion regardless the ambient brightness.

STAND-BY PERIOD

●	●	0s
○	●	30s
●	○	20min
○	○	+ ∞

The period of light keeping low output before it's completely switched off. When it's preset as "←", the light always keep at low output if no movement in the detection area and doesn't turn off.

STAND-BY DIMMING LEVEL

●	●	10%
○	●	20%
●	○	30%
○	○	50%

The definition of low output in the standby period.

APPLICATION

1. AUTOMATICALLY ON/OFF FUNCTION:

Light on when detect movement and off after people leave at night. Applications: Corridor, Staircase.

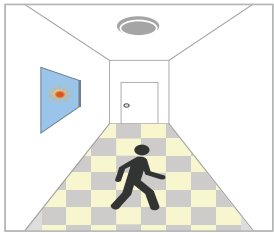

With sufficient daylight, even when motion detected, light remains OFF.

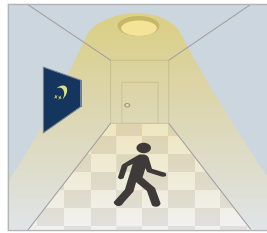

With insufficient daylight, when motion detected, light ON.

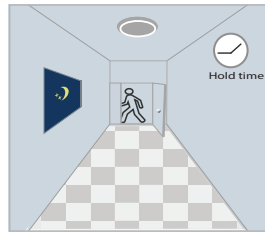

After the last detection and the present hold time elapsed, light OFF.

2. NO DAYLIGHT FUNCTION

The daylight threshold is set to "Disable".

Light on when detect movement, After people leave, Light off after stand-by period.

Applications: Dim places such as Basement Parking, Underpass.



When motion is detected, the sensor will switch on the light to 100% brightness.

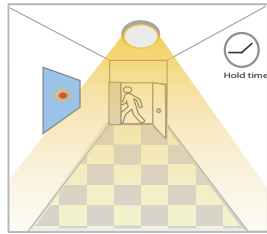

After people leave the detection area, light remains 100% brightness within hold time.

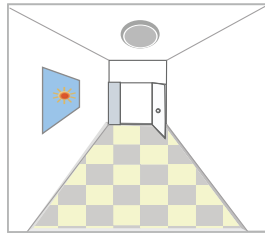

After the last detection and the present hold time elapsed, light OFF.

3. FUNCTION DEMO - DIMMABLE CONTROL/CORRIDOR FUNCTION

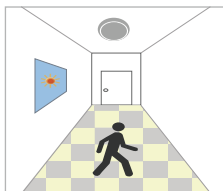

With sufficient daylight, even when motion detected, light remains OFF.



With insufficient daylight, when motion detected, light ON.

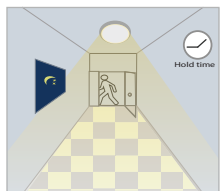

After last detection, the light will be dimmed down to the stand-by dimming level (10%,20%,30% or 50%)

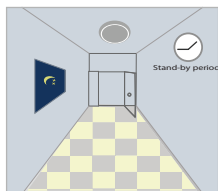

After the stand-by period, light OFF.

INSTALL METHOD

4 WAYS OF INSTALLATION

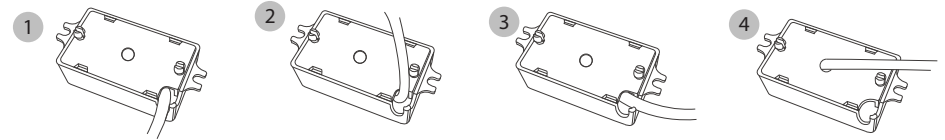

CABLE ON CENTER

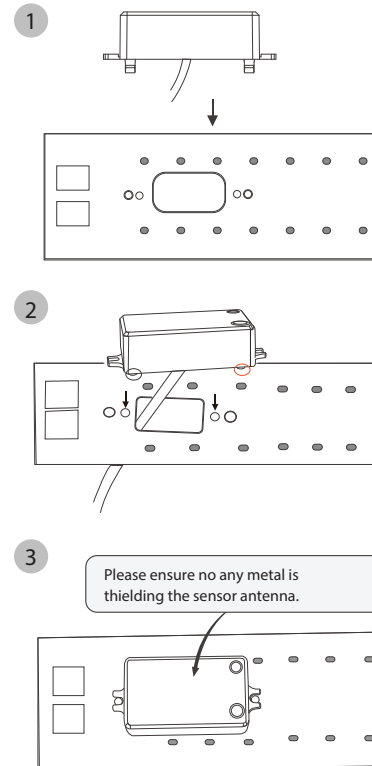

CABLE ON TIP SIDE

