

**FREE  
PATTERN**

Freshly Made to bring your ideas to life.



## Butterfly Quilt (Q-015B) by Melissa Stramel

Difficulty Level: Beginner  
Finished Size: 76" x 88"

# Disney PRINCESS

HEART OF A PRINCESS

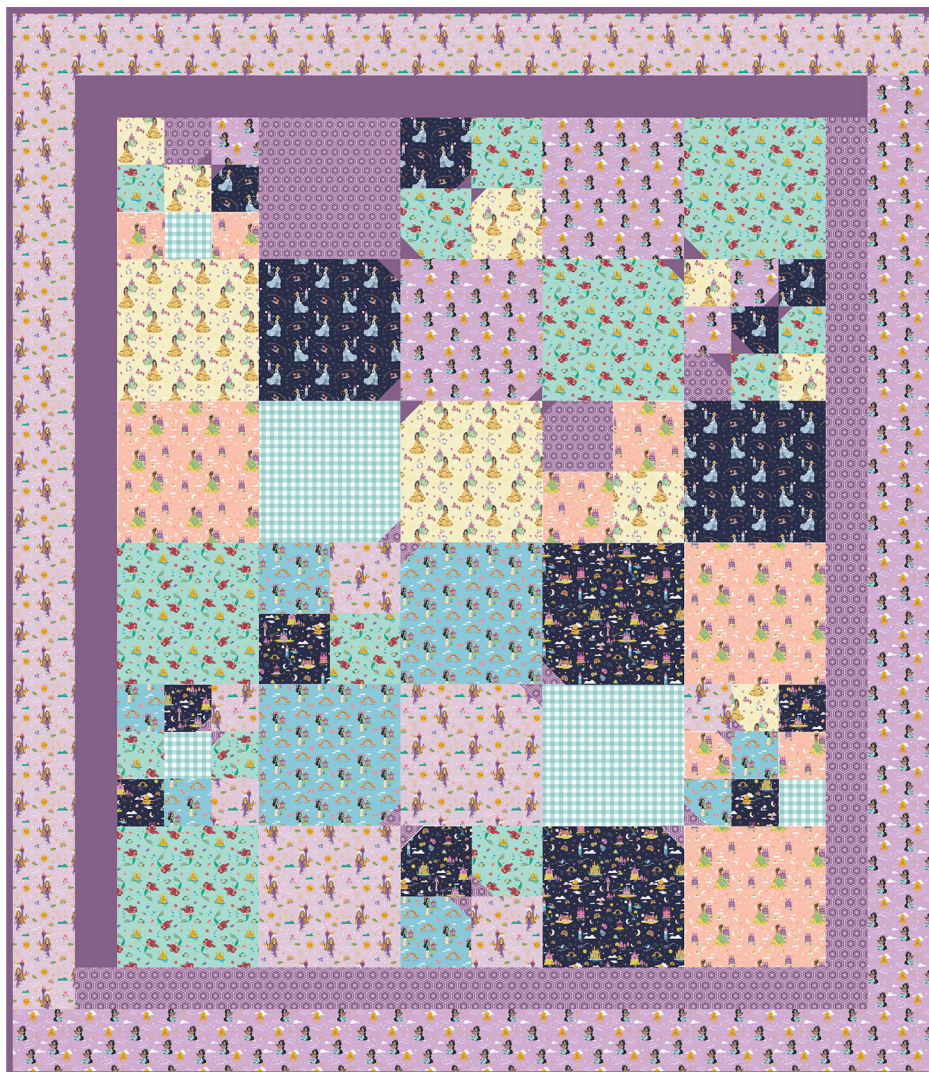

Exclusive Quilt Design by Melissa Stramel of Lilac Lane Patterns for Camelot Fabrics.  
The direction of the fabrics in the digital imagery may not be accurate to the final product.  
© Disney

### Fabric requirements



Fabric A: 214-0032  
2-1/8 yards  
(includes binding)



Fabric B: 2142-0032  
2-1/8 yard

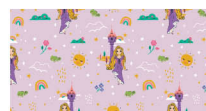

Fabric C: 85102108 03  
2-1/4 yards

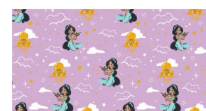

Fabric D: 85102107 02  
2-1/4 yard



Fabric E: 85102106 03  
1/2 yard

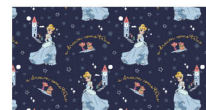

Fabric F: 85102103 03  
1/2 yard

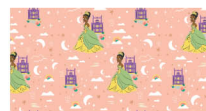

Fabric G: 85102109 01  
2/3 yard



Fabric H: 85102104 02  
1/2 yard



Fabric I: 85102105 03  
1/2 yard



Fabric J: 85102101 03  
1/2 yard



Fabric K: 85102104 02  
1/2 yard



Fabric L: 21007-0043  
1/2 yard



Fabric M: 2142-0032  
1/2 yard

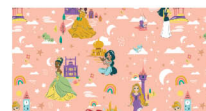

Suggested Backing:  
85102102 01  
5 yards



camelotfabrics.com  
info@camelotfabrics.com

COLLECTION  
Disney Heart of a Princess

## Other Supplies

- rotary cutter & fabric shears
- sewing machine
- iron & pressing surface
- needle & coordinating thread
- measuring tape/ruler

## Notes

- Please wash, dry & iron your fabric before beginning, and trim your selvages.
- Use the quilt layout on page 1 as your guide for all block composition.
- WOF = width of fabric.
- Use an accurate 1/4" seam allowance for all seams.
- Press your seams as you go; press open or toward the darker fabric, whichever you prefer.

### Fabric A

- Cut (2) strips 3-1/2" x 2-1/8 yds.
- Cut (11) strips 2-1/2" x 32" for Binding.
- Cut (1) strip 4" x 32" - sub-cut (8) 4" squares.
- Cut (1) strip 2" x 16" - sub-cut (8) 2" squares.

### Fabric B

- Cut (2) strips 3-1/2" x 2-1/8 yds.
- Cut (2) strips 4" x 32" - sub-cut (10) 4" squares & (4) 2" squares.

### Fabric C

- Cut (2) strips 5-1/2" x 2-1/4 yds.
- Cut (2) 12-1/2" squares, (2) 6-1/2" squares & (3) 4-1/2 squares.

### Fabric D

- Cut (2) strips 5-1/2" x 2-1/4 yds.
- Cut (2) 12-1/2" squares & (3) 4-1/2" squares.

### Backing

- Cut (2) Rectangles 2-1/2 yds x WOF.

## Squares

### Fabric E

- Cut (2) 12-1/2" squares, (2) 6-1/2" squares & (5) 4-1/2" squares.

### Fabric F

- Cut (2) 12-1/2" squares, (1) 6-1/2" square & (3) 4-1/2" squares.

### Fabric G

- Cut (3) 12-1/2" squares, (2) 6-1/2" squares & (3) 4-1/2" squares.

### Fabric H

- Cut (2) 12-1/2" squares, (2) 6-1/2" squares & (3) 4-1/2" squares.

### Fabric I

- Cut (2) 12-1/2" squares, (2) 6-1/2" squares & (4) 4-1/2" squares.

### Fabric J

- Cut (2) 12-1/2" squares, (2) 6-1/2" squares & (4) 4-1/2" squares.

### Fabric K

- Cut (2) 12-1/2" squares, (2) 6-1/2" squares & (2) 4-1/2" squares.

### Fabric L

- Cut (2) 12-1/2" squares & (2) 4-1/2" squares.

### Fabric M

- Cut (1) 12-1/2" square, (1) 6-1/2" square & (2) 4-1/2" squares.

## Assembly

### Butterfly Wings

We're using a small wing in our examples, but the method for adding the butterfly wings is the same for all wing/square combinations.

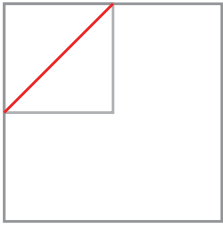

1. Place a small square (Fabric A or B) on top of a larger square (Fabrics E to M) as shown, Right Sides together. Draw a diagonal line between two opposite corners of the smaller square.

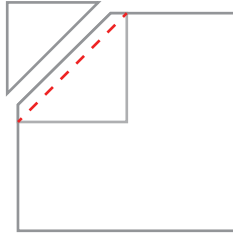

2. Sew along the marked line and trim the excess, leaving a 1/4" seam allowance.

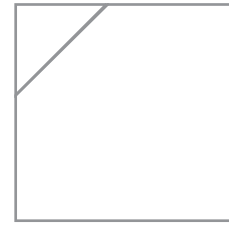

3. Open up your work and press the seam open.

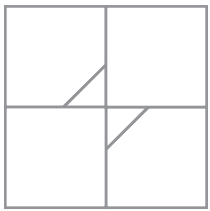

Good

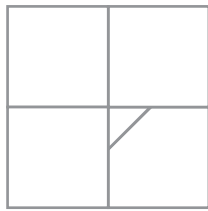

No Good

You may choose to place the butterfly wings exactly as we did, in which case you can use the quilt layout on page 1 as a guide, or you may want to place them differently. In this case, take care that each half-wing has a matching half-wing across from it when you put the blocks together.

4. Sew the 4-1/2" squares together in rows of three.



5. Assemble the 3-square rows into 3-row blocks.

Make (4) 9-square blocks, finished size 12-1/2" square.

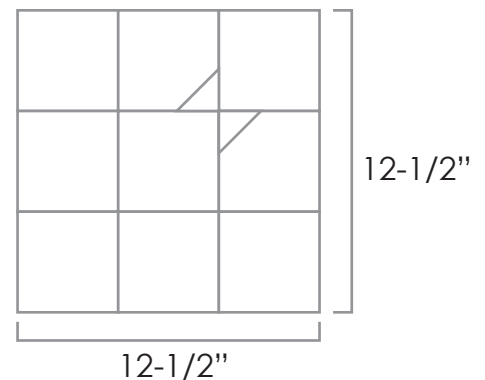

6. Sew the 6-1/2" squares together in pairs; sew the pairs together to make 4-square blocks.

Make (4) 4-square blocks, finished size 12-1/2" square.

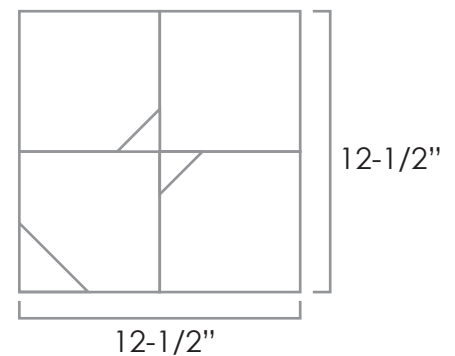

You should now have the following (30) 12-1/2" units:

(4) 9-squares composed of 4-1/2" squares.

(5) 4-squares composed of 6-1/2" squares.

(21) 12-1/2" squares.

7. Sew the 12-1/2" blocks together in rows of (5), according to the quilt layout on page 1.

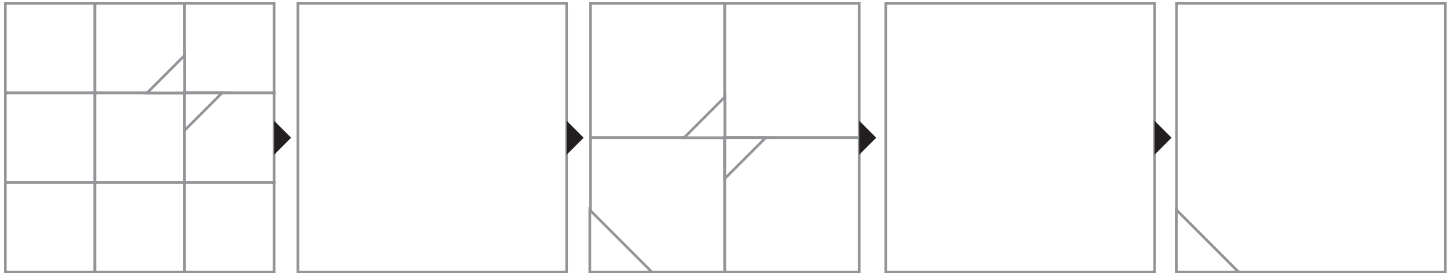

8. Sew the (6) 5-block rows together to complete the center of the quilt.

Adding the Borders - please see the diagram on the following page.

9. Measure the height of the quilt center through the middle. It should be about 72-1/2" tall, but use your own measurement for a perfect fit. Cut (1) 3-1/2" wide Fabric A strip to this length and sew it to the left-hand side of the quilt center. Cut (1) 3-1/2" wide Fabric B strip to this length and sew it to the right-hand side of the quilt center.

10. Measure the width of the quilt center through the middle, including the Inner Border pieces you just attached (about 67" wide). Cut (1) 3-1/2" wide Fabric A strip to this length and sew it to the top of the quilt center. Cut (1) 3-1/2" wide Fabric B strip to this length and sew it to the bottom of the quilt center.

11. Measure the height of the quilt center through the middle, including the Inner Border - it should be about 79" tall. Cut (1) 5-1/2" wide Fabric C strip to match this height and sew it to the left-hand side of the quilt center. Cut (1) 5-1/2" wide Fabric D strip to match this height and sew it to the right-hand side of the quilt center.

12. Measure the width of the quilt, including the Outer Border strips. Cut (1) 5-1/2" wide Fabric C strip to this length and sew it to the top of the quilt. Cut (1) 5-1/2" wide Fabric D strip to this length and sew it to the bottom of the quilt.

13. Piece the two Backing panels along their long edges with a 1/2" seam.

14. Sew the 2-1/2" wide Fabric A strips together end to end for the binding.

15. Quilt and bind your work as desired.

# Adding the Borders

