



E-Z ANCHOR PULLER MFG. CO.
America's Anchor Winch Since 1990



Hinged Pontoon & Retractable Tritoon Anchoring Solution Installation Reference Guide

Thank you for your interest in E-Z Anchor Puller and our **Pontoon Anchoring Solutions**. These systems were developed for pontoon and tritoon owners that want a better anchoring experience. This manual is intended as a reference guide to your boat's custom installation. We don't specify the steps or specifics, but offer guidance as to how the systems should be installed. After reviewing this manual, if there are any questions or concerns please contact customer support at **1.800.800.1640**.



As a reminder, this manual is intended solely for the E-Z Anchor Puller Mfg. Co. **Pontoon Anchoring Solutions** - for complete instructions on how to mount your HERO EX-1, EX-2 or PATRIOT EZ-1, please follow instructions provided in the **Hero, Patriot & Rebel Installation Manual** included with your drum anchor winch purchase.

The E-Z Anchor Puller Pontoon Anchoring Solutions are patent-pending systems created **solely** for the E-Z Anchor Puller *Hero EX-1*, *Hero EX-2*, or *Patriot EZ-1* drum anchor winch, and was **manufactured with the intention of being its own separate device** to be purchased in addition to an E-Z Anchor Puller drum anchor winch. E-Z Anchor Puller's patent-pending pontoon anchoring solution does not include the anchor, rode or the drum anchor winch.

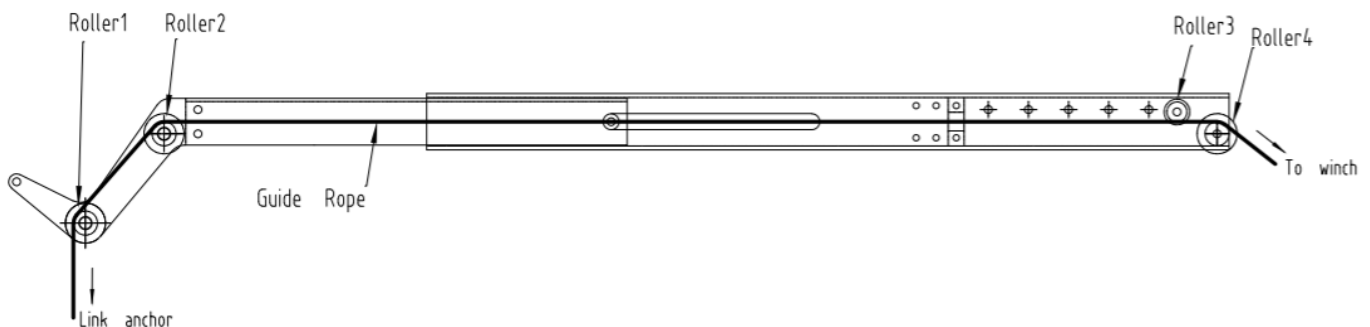

**If you have any questions or concerns,
please contact technical support at 1.800.800.1640**

Pontoon Anchoring Solution Guide Index:

Pontoon Anchoring Solution Disclaimer	Page 3
Anchor Winch Installation Briefing	Page 4
Winch Mounting Plates	Page 5 - 6
Anchoring Suggestion for Your Solution	Page 6
Included Pontoon Solution Hardware	Page 7
Hinged Pontoon Anchoring Solution Installation	Page 7 - 8
Retractable Pontoon Anchoring Solution Installation	Page 9 - 11
Wiring Diagram	Page 12
Full-Page Universal Undermount Diagram	Page 13
Warranty Information	Page 14
Warranty Form	Page 15

Drum Anchor Winch Resources

Hero EX-1, EX-2 and Patriot EZ-1 Printable Drawings:

<https://www.ezanchorpuller.com/pages/drawings>

Hero, Patriot & Rebel Manual Download:

<https://www.ezanchorpuller.com/pages/manuals>

Warranty & Guarantee for Hero EX-1, EX-2 & Patriot EZ-1 anchor winch

<https://www.ezanchorpuller.com/pages/warranty-information>

Manufacturer Information in Footer:

Email questions to contactus@ezanchorpuller.com

Retractable Tritoon & Hinged Pontoon Anchoring Solution Disclaimer

Each of E-Z Anchor Puller's pontoon anchoring solutions (the *Retractable Tritoon Anchoring Solution* or *Hinged Pontoon Anchoring Solution*) are patent-pending systems created **solely** to be powered by E-Z Anchor Puller's **Hero EX-1**, **Hero EX-2**, or **Patriot EZ-1** drum anchor winch, and was manufactured with the intention of being its own, separate device to be purchased **in addition to** an E-Z Anchor Puller drum anchor winch. E-Z Anchor Puller's patent pending pontoon anchoring solutions do not include the anchor, anchor rode or the drum anchor winch.

These systems are designed around the structural limitations of the deck or crossmembers of the pontoon / tritoon. Therefore a claw, danforth or plow-style anchor are not recommended as they do not easily break away when retrieving the anchor from lake or river beds.

Although the lifting force of the winch is great, the installation of the winch to the crossmembers of the pontoon or tritoon is not recommended to apply more force / torque than needed to lift an easily dislodged anchor, such as a river or mushroom style.



The Retractable Tritoon Anchoring Solution (**Retractable**) and Hinged Pontoon Anchoring Solution (**Hinged**) kits consist of the following components: raceway, U-bracket raceway mount (pictured left), L-bracket mounts and bolt, bow roller, string rode guide and universal underside mounting plate. Each anchoring solution contains a similar raceway that mounts to the underside of the crossmembers of the pontoon or tritoon.

The difference between the **Retractable** and **Hinged** systems lies within the hollow raceway we provide: the Hinged system has a folding bow roller that lifts the anchor up and out-of-the-way of a pull-in dock, while the Retractable system has an internal compression spring that allows the bow roller and anchor to be hidden under the deck of the boat when anchor and anchor rode are fully retrieved. Both raceways have several pre-drilled holes to correctly locate the included mounting tabs and U-shaped mounting bracket to the underside of the boat.

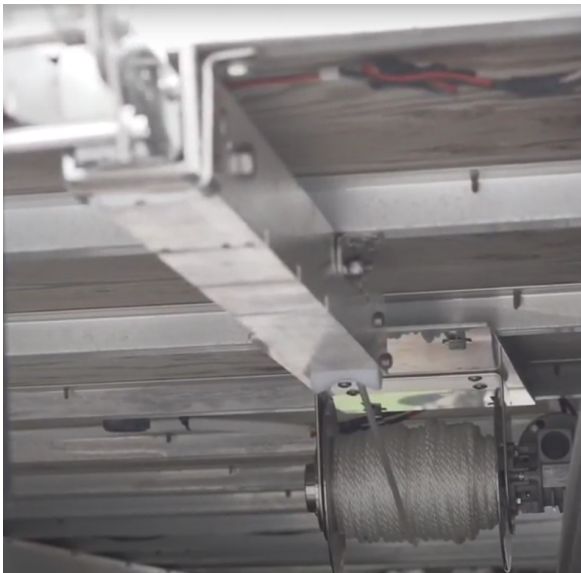

The solution is mounted below-deck on the aluminium crossmembers of the pontoon/tritoon or drilled into the "underskin" of the boat securely fastening it. Tips on installing the Retractable/Hinged underskin on pg 6

Getting Started: Mounting your E-Z Anchor Puller Winch to your Pontoon



Pictured left: the Hero EX-1 / Hero EX-2 or Patriot EZ-1 drum anchor winch you purchase in addition to your Pontoon Anchoring Solution selection comes with the pictured mounting hardware.

**NOTE - you WILL NOT use the drum anchor winch mounting plate for the pontoon anchoring solution (pictured left) - see page 6 for the Universal Mounting Plate*

Mounting your E-Z Anchor Puller Winch to your Pontoon

The Hero EX-1, Hero EX-2, or Patriot EZ-1 drum anchor winch should be installed between 6-to-24 inches away from the Hinged / Retractable square tube raceway and mounted onto the Universal Underside Mounting Plate, pictured on Page 13. The **Universal Underside Mount**, which can be applicable to any one of three unit sizes is the standard, included mounting plate for any anchor winch purchased. The bolts provided for the drum anchor winch are included in your anchor winch purchase, **not** in your pontoon anchoring solution kit.

Page 6 further explains how to correctly mount the universal mounting plate in regards to winch size and the boat's build. Refer to the instructions below regarding additional tips to mount your winch **in addition to** your Hero, Patriot or Rebel Manual.

Remember: **the bolts for your Hero or Patriot drum anchor winch are included with the anchor winch, not in the pontoon anchoring solution kit.**

Locate the drum anchor winch in a suitable position so there is no interference from other ropes or objects. Ensure that the rope has a clear lead to the winch. Ensure that there is sufficient room to run the electrical cables to the winch underneath the deck.

1. Both exposed wires* from the E-Z Anchor Puller motor must be connected via joiners/solder and then heat shrink, including internal silicon to wires (thicker wire, see bottom of page for wiring size) to eliminate any corrosion or water entering wires when attaching power cables to other attachments.
2. The drum must be in-line and centered to the guide roller on the raceway to ensure an even spread of the rope and chain to the drum.
3. Gearbox output flange to drum bracket can rotate in eight different mounting positions for your motor and gearbox components. This will allow you to position motor/gearbox at the most convenient configuration required.

for wiring help, see page 10

What's the Best Anchor for the Pontoon Solution?

The River and/or Mushroom-Style anchor is made in the shape of an upside-down mushroom with a lip around the mushroom cap. These anchors settle nicely into soft surfaces to hold your boat while you enjoy your day out on the water. The Mushroom / River Anchor gets its holding power by sinking into soft-bottom sediments found at the bottom of slow-moving rivers and stillwater lakes. This shape of anchor “suctions” itself into the silt and mud of the lake or river you are boating in, making it difficult for this anchor to break loose.

This system and it's installation is designed & rated for the following styles of anchors up to 30 pounds:



River Anchor



Mushroom Anchor

You should NEVER depend on a mushroom anchor to hold a boat in rough water or rough weather!

What's the Best Rope/Chain Configuration for the Pontoon Solution?

Series	Model #	Suggested Boat Length													
		18' - 21'		21' - 24'		24' - 27'			27' - 35'			35' - 45'		45' - 55'	
		1/4" Line	1/4" Chain	5/16" Line	1/4" Chain	3/8" Line	1/4" Chain	5/16" Chain	1/2" line	1/4" Chain	5/16" Chain	5/8" Line	5/16" Chain	3/4" Line	3/8" Chain
HERO	EX-1	250'	10'	175'	10'	125'	10'								
HERO	EX-2	375'	10'	225'	10'	175'	10'		125'	10'					

While anchoring needs across the United States may be vastly different, E-Z Anchor Puller Mfg. Co. recommends no more than 3X the length of anchor rode to the depth of the body of water customers are pontooning in. Also, the E-Z Anchor Puller Retractable and Hinged manufactured solutions work best with chain diameters no larger than 5/16". See the Hero rope and chain chart below for drum winch rope capacities:

Tips for Rope Spooling on your new Solution:

Position the drum anchor winch carefully checking rope path before mounting to your deck or bulkhead. Naturally, rope does not want to lay on top of itself: it wants to lay in between each “ring”, and the further back the installation is from the roller the more even your lay will be with each use. When you first receive your drum winch, spool the rope on wet the first time and take your time to ensure it is even: this will be the most even lay on your spool. E-Z Anchor Puller drums are specifically engineered to the width and height optimal for the most even lay, all the time! Leave at least, 24 inches from the roller and more if you can. When operating in shallow water, avoid overloading spool / drum with rope and chain

Understanding the Universal Underside Deck Mounting Plate

Included Kit Option for Hero EX-1, EX-2 or Patriot EZ-1 Installation

The universal underside mounting plate (pictured below) mounts the drum anchor winch onto the crossmembers and is included with every kit. The four mounting slots are on each corner of the universal mounting plate, which is designed to be used in conjunction with either the Hero EX-1, Hero EX-2 or Patriot EZ-1. For any unit, be sure to calculate where you will drill into the aluminium C-Channel crossmembers of your pontoon before the Universal Underside Plate via the adjustable mounting slots. These adjustable slots on each corner are designed for crossmembers between 16 to 26 inches, ensuring that any brand pontoon/tritoon can be equipped with the Hinged/Retractable.

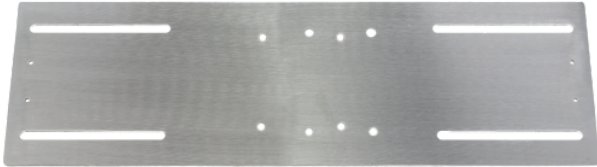

In addition to the four adjustable slots, you will see four (4) holes that are drilled towards the middle of the plate. If you own a **Hero EX-1** unit, attach the drum anchor winch to the Universal Mounting Plate using the four (4) smaller holes *only*.

The **Hero EX-2** or **Patriot EZ-1** drum anchor winch will be attached to the mounting plate using the four (4) larger holes. Additional holes are drilled into the plate for the optional add-on wifi wireless camera that would be focused on the drum anchor winch if purchased. These four (4) 1/4"-20 holes are located on either side of See **page 13** for more details.

If the pontoon/tritoon that is being equipped with one of the anchoring solutions has flat, aluminium underskin in addition of aluminium crossmembers, E-Z Anchor Puller recommends taking these tools and steps to securely and efficiently install the chosen solution:

- Rivet Nut/ Plus nut Hardware
- Hole Saw
- Anti-Seize
- Measuring Tape
- Pen or Marker

Be aware of the location that you wish to install the winch and carefully measure and mark where you plan to drill into the underskin to mount the plate and anchor winch. Be aware that some pontoon skins are thicker than others and because body styles are different, there could be bends in the skin when measuring for winch and raceway placement. It is best practice to center the winch as evenly as possible between the tubes of the pontoon/tritoon so it is free of obstructions while in operation. Use a hole saw to drill holes large enough, but also snug enough to hold the plus nuts where applicable. Always use anti-seize lubricant on bolts, pre-threading.



Attach the mounting plate to the aluminium crossmembers of your pontoon with the following hardware listed below:

Attach the mounting plate to the aluminium crossmembers of your pontoon with the following hardware listed below:

Getting Started: Included Hardware in the Pontoon Anchoring Solutions

The hardware included in your pontoon anchoring solution should be packaged in a clear plastic bag:

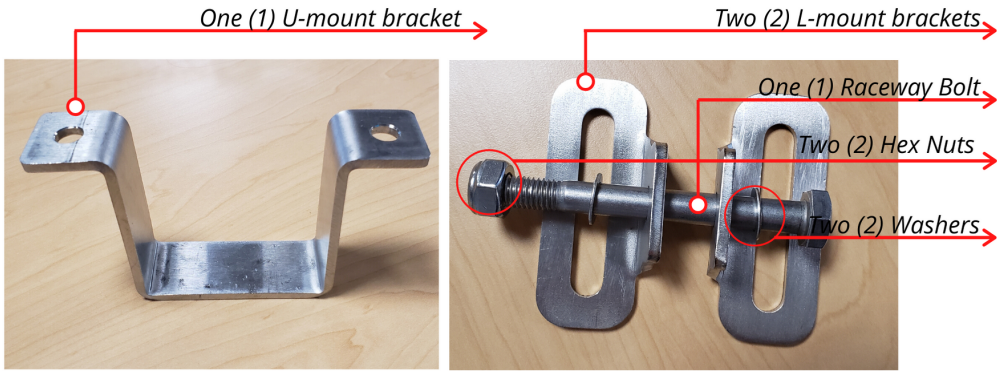

- (8) each x 18-8 Stainless Steel Hex Head Screw, 3/8"-16 Thread Size, 1-1/4" Long
- (8) each x 18-8 Stainless Steel Nylon-Insert Locknut, 3/8"-16 Thread Size

- (18) each x 18-8 Stainless Steel Washer for 3/8" Screw Size, 0.406" ID, 0.875" OD

Warning! Please use extreme caution before removing the through bolt as the inner spring is fully collapsed and under tension.

With a second person, hold both ends of the raceway and roller so you can slowly let the inner spring extend before installation.

Before using the stainless steel nuts and bolts be sure to apply an anti-seize lubricant to prevent the nylon lock nut from galling or seizing on the bolt as it is tightened. Be sure to remove the front through bolt from the raceway to allow the inner raceway to extend and retract in the outer raceway.

Hinged Pontoon Anchoring Solution Raceway & Bow Roller Installation

The hinged-style pontoon solution should be placed so that the bow roller head protrudes from underneath the deck, as shown in the two diagrams provided. The sleeve of the hollow raceway, which is immediately connected to the hinged bow roller's head, will be placed **directly on the edge** of the bullnose/front of decking bracket, which secures the square, hollow raceway to the vessel's crossmember with the **3/8" x 1-1/4" SS Hex Bolt** and **3/8" SS Lock Nut** and the two (2) rear slidable L-Brackets with a connecting bolt.

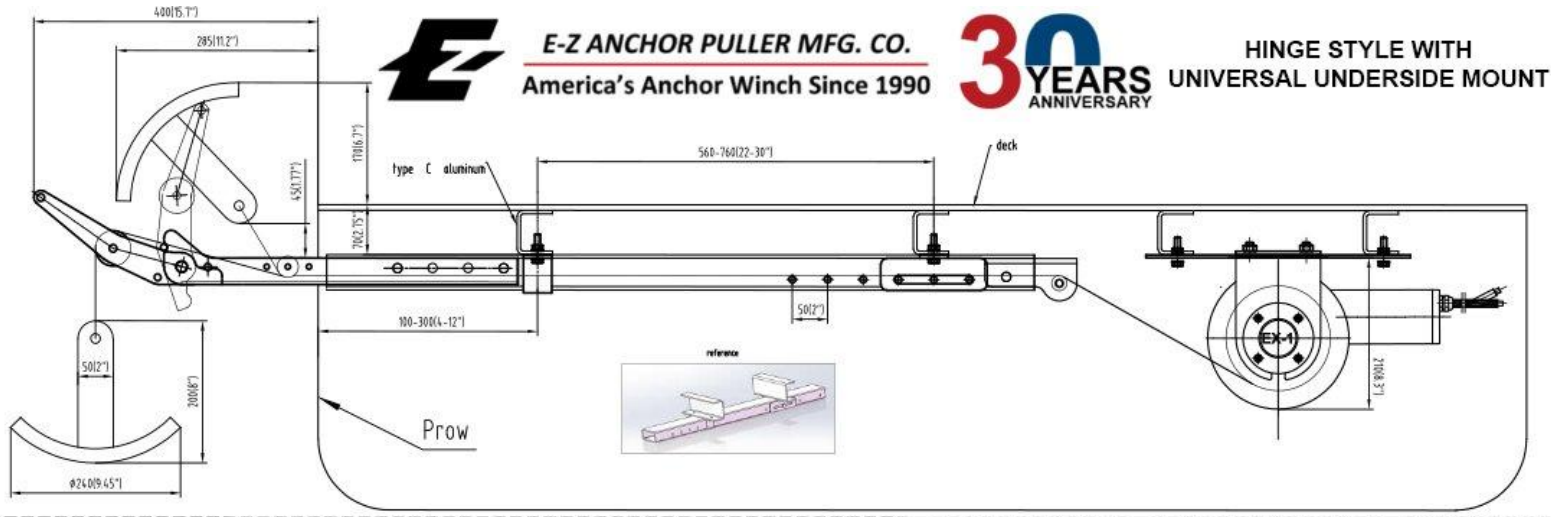

You will notice there are four (4) holes towards the rear/drum winch-end of the hollow raceway. This is to ensure that you can mount your aluminium raceway to the crossmembers, no matter the make and model of your vessel. Choose where to attach your L-mount brackets then flip them towards the vessel's crossmember and drill the **3/8" x 1-1/4" SS Hex Bolts & 3/8" SS Lock Nuts** in. *Please keep in mind that the anchor winch and pontoon anchoring solution will be mounted in the middle of a pontoon, but to the left or right of a tritoon's middle tube.*

Hinged Rope Installation Guide

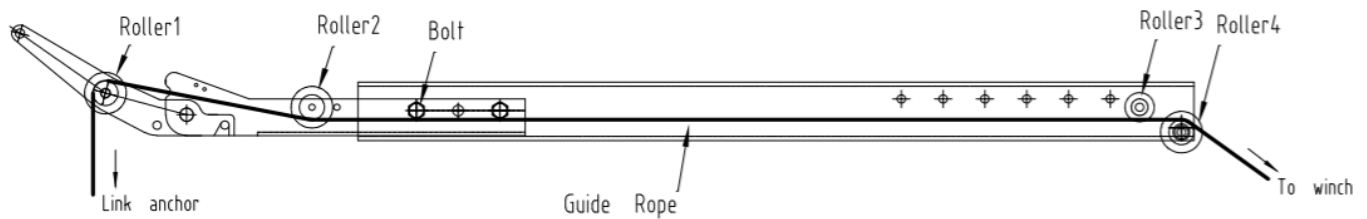

There are several ways to thread your anchor rode through the hinged pontoon anchoring solution, regardless of whether or not you have already spooled your Hero EX-1, Hero EX-2 or Patriot EZ-1. Every pontoon anchoring solution will have a thread "string rode guide" that travels through the hollow tube raceway from the rear/anchor winch end to the head of your front view of the solution. One method to thread your anchor rode through the raceway, is to tie the excess string wrapped around the winch end of your solution and tie it to your

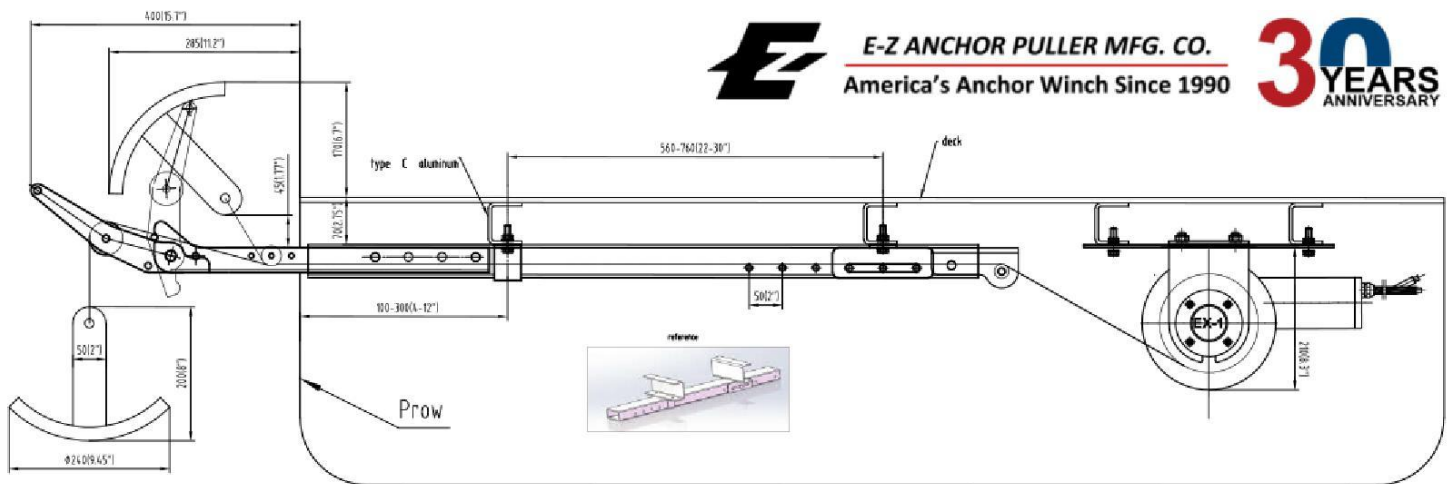

rode. Then, gently tug the thread toward the other end until the anchor rode travels all the way through.

If your drum winch is already spooled, detach your anchor from your anchor rode and winch. Once there is only anchor rode on the spool, tie the end of your anchor rode to the string behind roller 4, and pull the anchor rode through from roller 1 and the front of your retractable bow roller until the anchor rode is completely threaded through. Then dispose of the string and re-attach your anchor. Please note that your mounting bolts for your Hero or Patriot drum winch were included with your anchor winch. Refer to the Hero, Patriot & Rebel Manual for mounting instructions. View Page 10 for an example of the string rode guide.

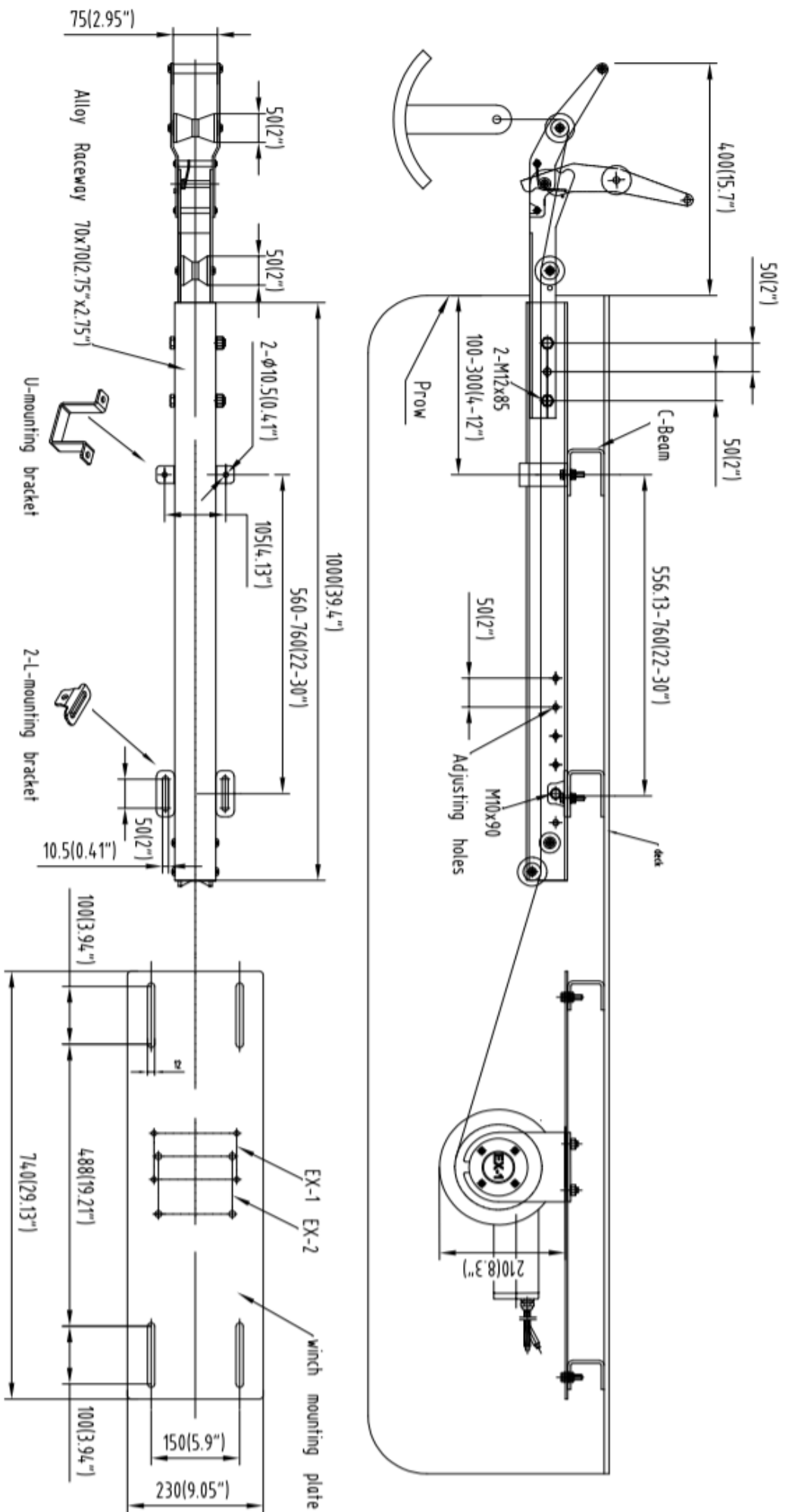

Retractable Tritoon Anchoring Solution Raceway & Bow Roller Installation

The Retractable Style should be installed so the raceway is 10-12 inches in from the front of the boat so that, when fully retracted, it is under the deck out of sight as shown in the figure below. In this solution, we've provided three (3) mounting brackets: the front U-shaped bracket, which secures the square, hollow raceway to the vessel's crossmember with a **3/8" x 1-1/4" SS Hex Bolt and 3/8" SS Lock Nut**, and the two (2) rear slidable L-mounting brackets with a connecting bolt. You will notice there are four (4) holes towards the rear/drum winch-end of the hollow raceway. This is to ensure that you can mount your aluminium raceway to the crossmembers, no matter the make and model of your vessel. Choose where to attach your L-mount brackets, using **3/8" x 1-1/4" SS Hex Bolt and 3/8" SS Lock Nut**, then flip them towards the vessel's crossmember and drill the bolts in.

Retractable Rope Installation Guide

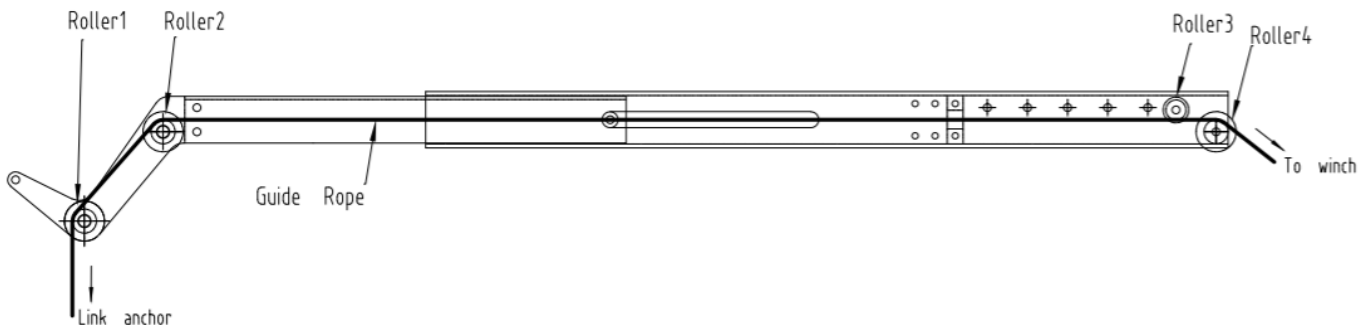

There are several ways to thread your anchor rode through the hinged pontoon anchoring solution, regardless of whether or not you have already spooled your Hero EX-1, Hero EX-2 or Patriot EZ-1. Every pontoon anchoring solution will have a thread that travels through the hollow tube raceway from the rear/anchor winch side to the head of your pontoon solution. One method to thread your anchor rode through the raceway, is to tie the excess string wrapped around the winch end of your solution and tie it to your rode. Then, gently tug the thread toward the other end until the anchor rode travels all the way through.

Anchoring / Rode Warnings

- During retrieval or deployment, NEVER place any obstruction or tool in or near the rope spool.
- Do NOT pull a load greater than what is rated for the anchor winch or pontoon solution.
- Ensure the anchor rode is properly spooled on the winch & properly threaded through the solution before using.

Optional Add-On Solution Accessories Available to You



- **12v Long-Range Wireless Remote:** The wireless connects to the anchor winch solenoid and allows customers to deploy/retrieve away from the rocker switch. See the Wireless Remote Manual online
- **Wifi Waterproof Video Camera:** The wifi camera is bolted into the universal underside mount and points toward the winch. Connect the camera to your phone via a wifi signal after downloading the app via scan code in the user manual.

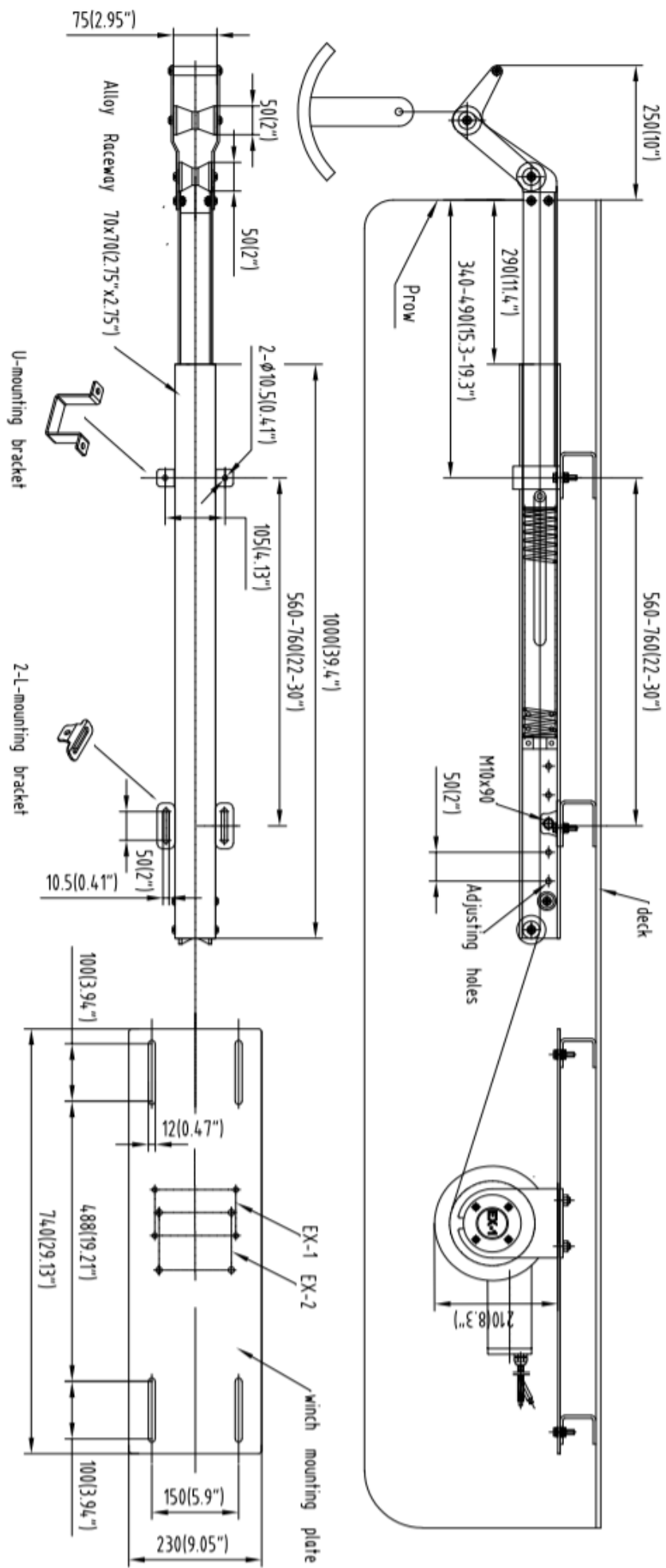

Wiring Diagram for Hero EX-1/ EX-2 & Patriot EZ-1

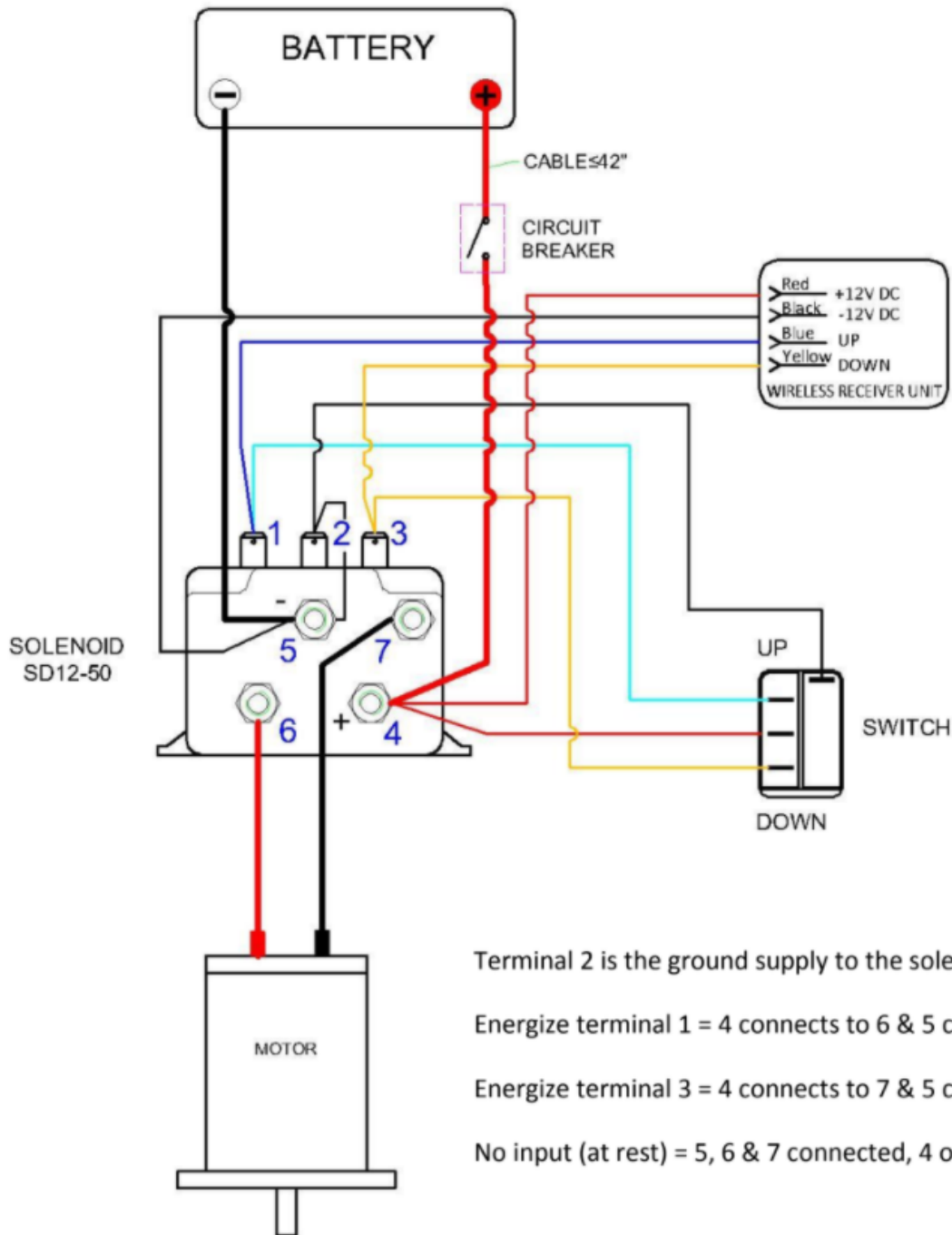

Universal Underside Deck Mount

Drum anchor winch mounting plate for Hero EX-1, Hero EX-2 & Patriot EZ-1

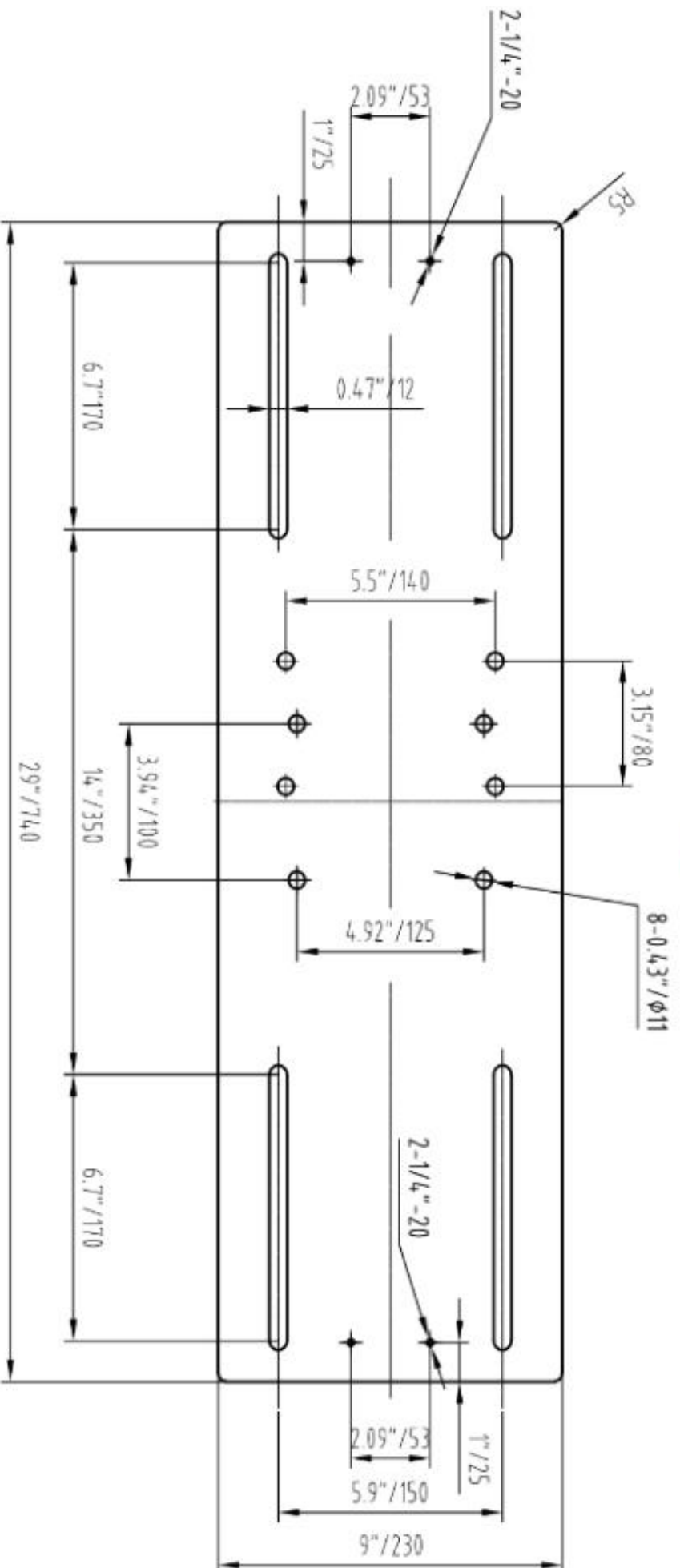

WARRANTY INFORMATION

****The agreement entered when you make an E-Z Anchor Puller purchase is subject to the following conditions limitations:**

- **7-year warranty** for **recreational** vessel usage on winch motors and gearboxes w/ 3-year warranty on solenoids, switches, circuit breakers and fast fall systems
- **3-year warranty** for **commercial** vessel usage on winch motors and gearboxes w/ 1-year warranty on solenoids, switches, circuit breakers and fast fall systems.
 - Both warranty agreements include replacement of faulty part(s) materials and/or workmanship

- The Product(s) sold must be free from defects in the materials, workmanship and packaging

- If you suspect the product(s) of being defective in workmanship or materials upon purchase, stop using the product(s) & contact E-Z Anchor Puller at **1.800.800.1640** to report the defect within 7 days within inspection.

Purchaser understands that they are responsible for any/all charges associated with removal, returning the faulty goods to E-Z Anchor Puller for warranty claim and reinstallation;

- Any damage sustained to any vessel, property or equipment or persons due to the installation or use of a E-Z Anchor Puller product, as far as is permitted by consumer law, is excluded from this warranty;

- No representative or agent of E-Z Anchor Puller has the authority to make any decisions or agreements regarding warranty with you without the prior agreement with E-Z Anchor Puller Mfg. Co., LLC. directly; This warranty shall be limited or null and void if any of the following occur:

- The improper installation of a E-Z Anchor Puller, including not adhering to the installation guidelines contained within this manual;

- The improper and irregular maintenance, repair or service of your E-Z Anchor Puller product;

- The improper use or incorrect application of your E-Z Anchor Puller product;

- Improper modification/s made to the E-Z Anchor Puller; The warranty does not cover any loss, damage, harm or claim associated with or as a result of an accident or natural disaster.

- If you are unsure about anything contained in this document please contact E-Z Anchor Puller for clarification.

****The warranty period begins on the date the invoice is generated and the written agreement is received. The warranty CANNOT be honored if the appropriate documentation has not been provided or if it is incomplete. See the next page for warranty form & instructions****



E-Z ANCHOR PULLER MFG. CO.
 America's Anchor Winch Since 1990



To be eligible for warranty protection please complete this form within 90 days of purchase & post to:

Toll-Free Fax: 855.855.1540 or support@ezanchorpuller.com

Purchaser Info:

Company: _____ Name: _____

Address: _____

City: _____ State: _____ Zip: _____

Email Address: _____ Cell Phone #: _____

Supplier / Installer Info:

Company: _____ Name: _____

Address: _____

City: _____ State: _____ Zip: _____

Email Address: _____ Cell Phone #: _____

(Circle Unit): EX-1 / EX-2 / EZ-1 + (Circle Solution): Retractable/ Hinged

Boat Manufacturer: _____ Boat Model & Length: _____

Gauge of Battery Wire: _____ Distance from Battery: _____

Date Received: _____ Date Installed: _____

You must include a copy of the invoice / receipt for the drum anchor winch or the boat if the drum anchor winch came installed from a dealer. Failure to register the motor's serial number will void the warranty!

Winch Motor Model #: _____

Winch Motor Serial #: _____