



E-Z ANCHOR PULLER MFG. CO.
America's Anchor Winch Since 1990

30 YEARS
ANNIVERSARY

Complete Drum Anchor Winch Series Operation Manual



HERO

PATRIOT

REBEL

KIT INCLUDES:

- Forward & Reversing Waterproof Solenoid
- Momentary Rocker Switch
- Waterproof Circuit Breaker
- All-in-One Emergency Drive Key
- 1/4" Aluminum Backing Plate
- Stainless Steel Nuts, Bolts and Washers

! CAUTION: READ AND UNDERSTAND THIS MANUAL BEFORE INSTALLATION & OPERATION OF EZ ANCHOR PULLERS. SEE SAFEGUARDS AND WARNINGS !

Send Questions to support@ezanchorpuller.com or call toll-free at the number listed in the footer of this manual.

PRODUCT DIAGRAM & MANUAL INDEX

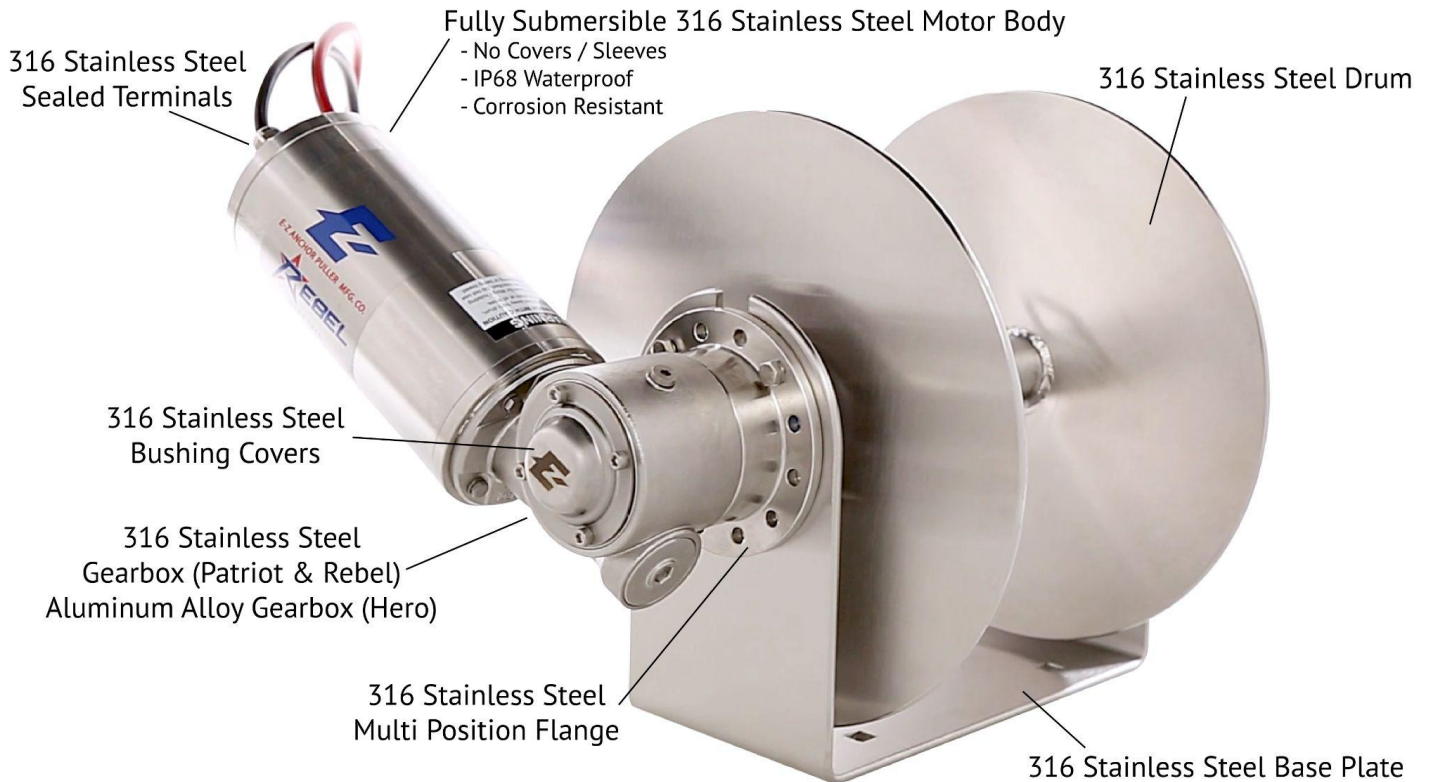

Product Introduction & Handy Hints	Page 3
Drum Winch Safety, Installation, Rope Guide & Operation	Page 4
Electrical Wiring / Cable Size & Voltage Chart	Page 7
Common Troubleshooting Solutions	Page 8
The Hero Series (EX-1, EX-2, EX-3) Wiring Diagram & Specs	Page 9
The Patriot Series (EZ-1, EZ-2, EZ-3) Wiring Diagram & Specs	Page 11
The Rebel Series (EZ-4, EZ-5, EZ-6) Wiring Diagram & Specs	Page 14
Rebel Series Installation/Wiring Instructions	Page 16
E-Z Anchor Puller Warranty Agreement	Page 18
E-Z Anchor Puller Warranty Form	Page 19

Thank you for purchasing an E-Z Anchor Puller Mfg. Co. drum anchor winch. E-Z Anchor Puller Mfg. Co. goes to great lengths to develop anchoring systems that not only meet all your performance and safety requirements, but are also designed with a style and finish that enhances the aesthetics of your vessel. Our commitment to quality, superior materials and processes is to ensure you will be pleased with your investment. Rest assured that through the correct installation, operation, and maintenance, your new E-Z Anchor Puller drum anchor winch will give you years of reliable performance!

This updated manual reflects the current product line of E-Z Anchor Puller Mfg. Co. and is intended to further clarify and determine specific instructions to each anchor winch series we provide. While the Hero, Patriot, and Rebel drum anchor winches are separated in this manual to meet your specific needs, the following **Hints** and **Important Safety & Installation Section for Any Anchor Winch** sections are universally applicable.

Direct Drive vs. Free-Fall Operation: Our Hero and Patriot drum anchor winches are *direct drive*, meaning you will operate the anchor winch by pressing **and holding** the “down” side of your rocker switch until your anchor hits the bottom, then pressing the “up” to slightly raise the anchor until your vessel is held steadily in the designated area. To retrieve your anchor, press and hold the “up” side of your rocker switch until your anchor rope is neatly spooled back onto the winch and the anchor is fully retrieved.

Our Rebel series, however, is powered into *free-fall* mode by pressing the “down” side of your rocker switch **for 2 seconds**, then quickly releasing it. Your anchor will be deployed as fast as gravity allows it to go. **DO NOT ATTEMPT TO STOP YOUR ANCHOR MID-FREEFALL**. Doing so will cause irreparable damage to your anchor winch, and may cause serious injury. After your anchor hits the bottom, **press and hold the “up” side** of the rocker switch for about 5 seconds until you're steadily in position in the water. To raise your anchor with your Rebel anchor winch, press and hold the “up” side until your anchor is completely retrieved and your anchor rope is neatly spooled back onto the drum winch. For Rebel specifications, go to page 16 in the Rebel Installation Guide.

HANDY HINTS FOR INSTALLATION

- Locate the drum anchor winch in a suitable position so there is no interference from other ropes or objects. Ensure that the rope has a *clear* path & use a roller if required to direct the rope to the drum.
- Both exposed wires from the winch motor must be connected via joiners/solder and then heat shrink, including internal silicon to wires (see cable chart, page 7) to eliminate corrosion or water entering wires.
- The drum must be in-line and centered to your guide roller or hawsepipe and bowsprit to ensure an even spread of the rope and chain to the drum.
- Gearbox output multi-position flange (page 2) to drum bracket can rotate in eight different mounting positions for your motor and gearbox components
- Bushing and bushing hub; if bushing needs to be replaced just unbolt four screws to hub and replace bushing, you can purchase bushings by calling the manufacturer at the listed phone number.
- **Carefully** read the instructions provided in the manual sections that best apply to your Hero, Patriot or Rebel anchor winch. If there is any confusion or questions, call 1.800.800.1640 immediately.
- Ensure sufficient room to run electric cables to the drum anchor winch. Follow the instructions above including underdeck stiffening, alignment, mounting blocks and sealing procedures.
- To help the rope to lead onto the drum a minimum of 12”-24” / 30 -60 cm is recommended between the last roller and the drum anchor winch. If the drum anchor winch is being used inside a chain locker it is recommended to have a roller as wide as the spool / drum. See page 5 for more rope help.

IMPORTANT SAFETY & INSTALLATION SECTION FOR ANY ANCHOR WINCH

When boating in exceedingly rough waters, excessive strain on the winch may bend the shaft. Tie off to a cleat for your own safety and the safety of your anchor winch in cases of extreme rough waters.

WARNING! DO NOT OVERLOAD!

Drum anchor winches are designed to lift loose anchors, NOT to break anchors free from obstructions that may hinder your anchor from being retrieved. If anchor retrieval is impaired by high wind, heavy seas or the anchor is snagged, ease the load by either motoring or maneuvering slowly forward into the wind, until the anchor can be lifted vertically. **The anchor rope may BREAK before the winch stalls!**

DO NOT ATTEMPT PROLONGED PULLS AT HEAVY LOADS!

Under NO circumstances should the drum anchor winch be operated if it is stalled or overloaded.

Overloads can damage the winch and/or the rope and create unsafe operating conditions. If at all possible, check for the cause of the overload/stalled unit and rectify the issue before continuing the retrieval of your anchor.

The generator / main engine should be running during winch operation to minimize battery drain and maximize winch power and speed. If considerable winching is performed with the engine off, the battery may become too weak to restart the engine. Drum anchor winches are powerful machines: treat them with respect, use with caution and always follow the safety guidelines to get the most out of your new investment.

RULES FOR OPERATION & SAFETY

1. Keep the winching area clear whether you are operating it or not: ensure that hands, feet, hair and clothing are kept clear of the drum anchor winch and other loose gear when you're out on the water.
2. Inspect the anchor rope, chain and equipment frequently: a frayed rope or damaged splice to the chain should be replaced immediately.
3. **Periodically check the drum anchor winch installation to ensure that all bolts are tight.**
4. Never use your drum anchor winch for lifting or moving people. Ensure no one is swimming nearby as the anchor is lowered or retrieved.
5. This drum anchor winch is not designed or intended for overhead hoisting operations. Purchasing the winch with the intent to do so will void the warranty (see page 18).
6. Avoid continuous pulls from extreme angles. This will cause the rope to pile up on one end of the drum, jamming the rope in the winch and causing inevitable damage.
7. Always operate the drum anchor winch with an unobstructed view if possible.
8. **ONLY** use factory approved switches, remote controls and accessories. Use of non-factory approved components may cause injury or property damage and will void your warranty.
9. Do not machine or weld any part of the drum anchor winch. Such alterations may weaken the structural integrity and will void your warranty (see page 18).
10. Use suitable electrical wire gauges and connections between the battery, switch and other components. See *"Important Electrical Information,"* page 7, for details.

WINCH INSTALLATION INSTRUCTIONS FOR *ONLY HEROES and PATRIOTS

*Refer to page 16 for the Rebel Series Instructions

Ensure that the rope has a clear lead to the winch – use a roller if required to direct the anchor rope to the drum. Ensure that there is sufficient room to run the electrical cables to the winch underneath the deck. The winch can be mounted with the gearbox and motor facing either starboard or portside, depending on boater preference, and the anchor rope may be layed overfed or underfed. If in the event the winch is installed and operating in the opposite direction desired, simply switch the blue and yellow wires at the solenoid terminals. If the deck or bulkhead selected for mounting is angled or curved, a suitably shaped mounting block will be required to spread the load evenly over the deck surface and mount the winch on a level and even footing. Place the shaped mounting block (if required) onto the deck or bulkhead. Use the drum anchor winch as the layout template to mark the centers. Remove the winch and drill the holes.

Apply an appropriate marine-grade silicone sealant to the base plate and mounting block if required, taking care to align mounting holes when assembling. **For aluminum or steel hull vessels, it is important to insulate the drum anchor winch with a non-conductive gasket to avoid corrosion.** This also applies below deck with the mounting bolts, nuts and washers. Always use the included marine-grade aluminum alloy backing plate or a marine plywood or starboard stiffener of at least **16mm (5/8")** should be fitted to the underside of the deck to spread the load. Install and tighten mounting bolts.

ANCHOR LINE & CHAIN INSTRUCTIONS

***see exception for REBEL series at the end of this section**

In winding the chain and rope onto the drum of your anchor winch, the rope is wound over or under the shaft of the drum. Your rope should wind over or under based on how the winch is orientated on your boat. To install the anchor rope onto the drum, first insert the rope through the hole* on your Hero EX-1, EX-2 or EX-3 / Patriot

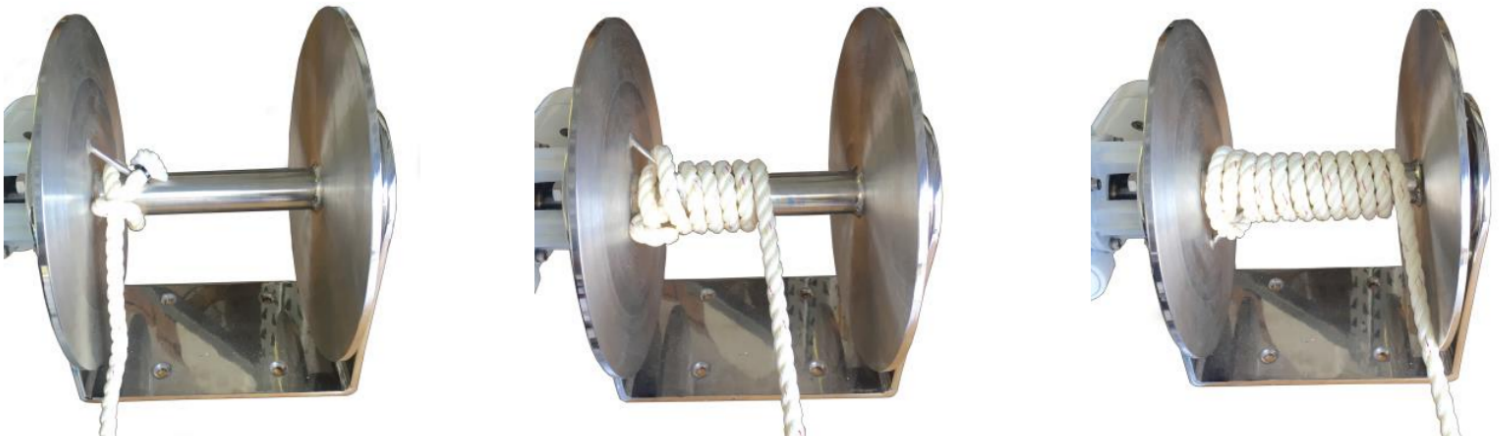

EZ-1, EZ-2 or EZ-3 then either tie it back onto itself or attach with a shackle and wind the rope onto the drum.

The chain / rope should be wound “thread lay”, with close, even winding throughout the length of the chain / rope. It is common practice to wet your anchor rope as you wind it onto the drum to establish this close, even winding. If wound unevenly, the turns of your anchor rope will bunch-up, cross wind and may be liable to form “doglegs” (i.e. causing kinks or odd bends in anchor rope), particularly on the more flexible chain / rope. **Never** fill the drum full to the rim or edge of the flanges. If possible, leave a clearance equivalent to **at least** two layers of chain / rope. A tension should be induced into the line as a tight winding is imperative. One person should

operate the drum anchor winch in the “UP” direction while a second person guides the wetted rope, making sure each turn is winding tightly with each turn.

* On the Rebel EZ-4, EZ-5 or EZ-6, insert your rope through the *welded rod*. **DO NOT insert anything in the hole of the rod/shaft of your Rebel series anchor winch** (See page 16).

Note: NEVER UNWIND THE LAST LAY OF LINE ON THE SPOOL!

The amount of chain can be lengthened or shortened to meet individual needs. In these situations, the amount of rope must be tailored to ensure there is a maintained clearance between the chain and the base plate. Avoid damage to the drum anchor winch or vessel when bringing the anchor up, it is a preferred practice to mark the chain/rope at approximately 6.5' and 16.5' (2m-5m) intervals from the anchor, to alert the operator to the anchor position.

BASIC MAINTENANCE PRACTICES & REPAIR : Periodically check tightness of mounting bolts and electrical connections. Remove any dirt or corrosion that may have accumulated on the electrical connections. Repair should be done by an authorized E-Z Anchor Puller Mfg. Co. Repair Centers Only. **Do not attempt to disassemble the gearbox, disassembly will void warranty.** The gear drive is filled and sealed at the factory with long life synthetic oil and does not require replacement. A rinse of fresh water on all your deck gear after every excursion ensures all salt deposits are kept to a minimum.

E-Z Anchor Puller Mfg. Co. recommends running the winch motor periodically if the vessel is not being used for a long period of time to keep all the moving parts lubricated. Always rinse off with fresh water after being exposed to corrosive environments to ensure that salt deposits and build up do not hinder anchor winch functionality.

LUBRICATION : The gearbox and drum bearings are permanently lubricated with a high-performance gear lube. If relubricating is necessary (after repair or disassembly) only use **Shell Alvenia EP2** or equivalent. All white bushings are self-lubricating and should not be lubricated as grease can reduce their efficiency and performance life.

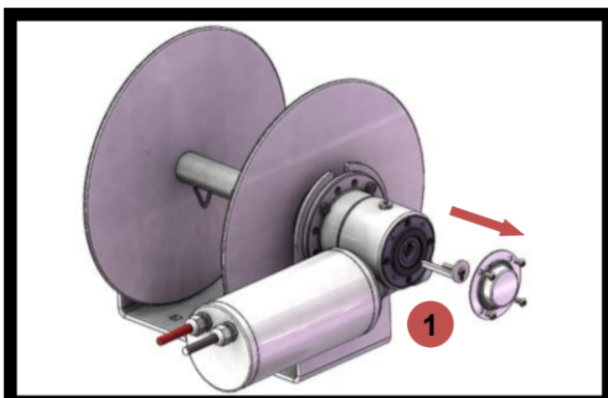

EMERGENCY FREE-SPOOL FEATURE FOR HERO & PATRIOT SERIES*

*For Specific REBEL SERIES emergency procedures, go to page 17.

If your boat should lose all power and you need to deploy the anchor, there is an emergency free spooling feature that will allow you to do so. In order to do so, simply take off the end cap of your gearbox and remove it's shaft key on the side of the gearbox by unscrewing ONLY the large screw, which will back out the drive key along with the bushing. Then retrieve the anchor rope by hand.

IMPORTANT ELECTRICAL INFORMATION: Circuit Breakers, Solenoids and Warranty

NOTICE** - If after wiring your anchor winch, your rocker switch operates “up” when holding the *down* side of your button (or vice versa), switch the leads on the solenoid terminals **1** and **3

IT IS **NECESSARY** TO INSTALL A CIRCUIT BREAKER WITH AN ISOLATION / RESET SWITCH TO ISOLATE THE DRUM ANCHOR WINCH WHEN NOT IN USE. This is to prevent the rope and chain from paying out if the winch is accidentally reversed. Circuit breakers *must* be fitted to ensure warranty. If the drum anchor winch is overloaded or stalled the circuit breaker automatically cuts off power to the winch and protects the wiring and motor. The circuit breaker should be located within 42" of the battery per *ABYC* boating standards. Furthermore, the circuit breaker **assists in the protection against overloading the motor**, however, they are not total protection against overloading and overloading the motor will void the warranty.

Deck Switches (if fitted) are **best** located to either port or starboard or directly behind the drum anchor winch in a position where it can be easily reached with your foot or knee, preferably where you can view the anchor and chain coming aboard.

CABLE SIZE CHART : In the boating world it is suggested that,

- 3% max voltage drop for conductors providing power to panels and switchboards, navigation lighting, bilge blowers, main DC feeders, and any other circuit where voltage drop should be kept to a minimum
 - 10% max voltage drop on conductors used for general lighting and other non-critical circuits
- Drum anchor winches are operable in the acceptable voltage loss range of 3% to 10%.

Batteries are best located as close to the drum anchor winch as possible.

Below is the minimum battery size and power requirements for E-Z Anchor Puller drum winches. All batteries need to be hard wired to the boat's motors to be continuously recharged by the alternators:

- *Marine Grade*
- *Dual Purpose or Starting*
- *Group 27 or larger*
- *750 CCA or more cold cranking amps*

(RC) Min @ 25 Amp should be 120+

Reserve Capacity (RC) is the number of minutes a fully charged battery at 80°F will discharge 25 amps until the battery drops below 10.5 volts.

Amp Hours (Ah) @ 20 Hr should be 70+

An amp hour (AH) is a rating usually found on deep cycle batteries. The standard rating is an amp rating taken for 20 hours.

Smaller diameter cables drop voltage considerably. Larger cables will reduce the voltage drop to the motor and the heat generated when operating the winch. Use the following guide to determine your required size:

<http://www.calculator.net/voltage-drop-calculator.html>

THE FOLLOWING CABLE SIZES MUST BE USED AS A MINIMUM:

12 Volt DC system with copper wire & conductors Using a 40 amp circuit breaker producing 400W:

- up to 15' from battery use 6 awg cable and experience 4% voltage drop
- up to 30' from battery use 4 awg cable and experience 5% voltage drop
- up to 40' from battery use 2 awg cable and experience 4% voltage drop

12 Volt DC system with copper wire & conductors Using a 60 amp circuit breaker producing 700W:

- up to 15' from battery use 6 awg cable and experience 6% voltage drop

- up to 30' from battery use 4 awg cable and experience 8% voltage drop
- up to 40' from battery use 2 awg cable and experience 6% voltage drop

12 Volt DC system with copper wire & conductors Using a 80 amp circuit breaker producing 900W:

- up to 15' from battery use 6 awg cable and experience 8% voltage drop
- up to 30' from battery use 4 awg cable and experience 9% voltage drop
- up to 40' from battery use 2 awg cable and experience 8% voltage drop

12 Volt DC system with copper wire & conductors Using a 100 amp circuit breaker producing 1100W:

- up to 15' from battery use 4 awg cable and experience 6% voltage drop
- up to 30' from battery use 2 awg cable and experience 8% voltage drop
- up to 45' from battery use 1 awg cable and experience 9% voltage drop

12 Volt DC system with copper wire & conductors Using a 120 amp circuit breaker producing 1250W:

- up to 15' from battery use 4 awg cable and experience 7% voltage drop
- up to 30' from battery use 2 awg cable and experience 9% voltage drop
- up to 45' from battery use 1/0 awg cable and experience 9% voltage drop
- up to 55' from battery use 2/0 awg cable and experience 9% voltage drop

COMMON TROUBLESHOOTING QUESTIONS FOR ANY ANCHOR WINCH *

*see additional chart for REBEL-specific inquiries on page 17.

Issue	Possible Cause(s)	Solution(s) *numbers correlate to each other
Motor Runs, but with Insufficient power or with low RPM	<ol style="list-style-type: none"> 1. Insufficient Battery 2. Electrical cables from battery to speed reducer is too small 3. Bad electrical connections 4. Insufficient charging system 	<ol style="list-style-type: none"> 1. Check battery terminal voltage under load. If 10 volts or less, replace or parallel another battery to it at the motor terminal. 2. Refer to cable guide, page 7 3. Check all connections for looseness or corrosion, then tighten, clean and grease if applicable 4. Insufficient charging system
Motor will not Operate	<ol style="list-style-type: none"> 1. Inoperative solenoid or stuck solenoid 2. Inoperative switch 3. Inoperative Motor 4. Loose connections 	<ol style="list-style-type: none"> 1. Check battery terminal voltage under load. If 10 volts or less, replace or parallel another battery to it at the motor terminal. 2. Check voltage and “on” connection, then check the back of the rocker switch and at solenoid terminals 3. If solenoids operate, check for voltage at motor terminals. Replace motor if needed. 4. Check all terminal connections
Rocker Switch Operates in Wrong Direction	<ol style="list-style-type: none"> 1. Rocker switch “up” button deploys rather than retrieves 	<ol style="list-style-type: none"> 1. Switch leads 1 and 3 on solenoid terminals. See diagram for specific units.



The Hero *Direct Drive* Series: EX-1 / EX-2 / EX-3 Installation Guide

**Wiring Diagram for Solenoid SD12-50 & Switch Gear for Winch
 EX-1 / EX-2 / EX-3**

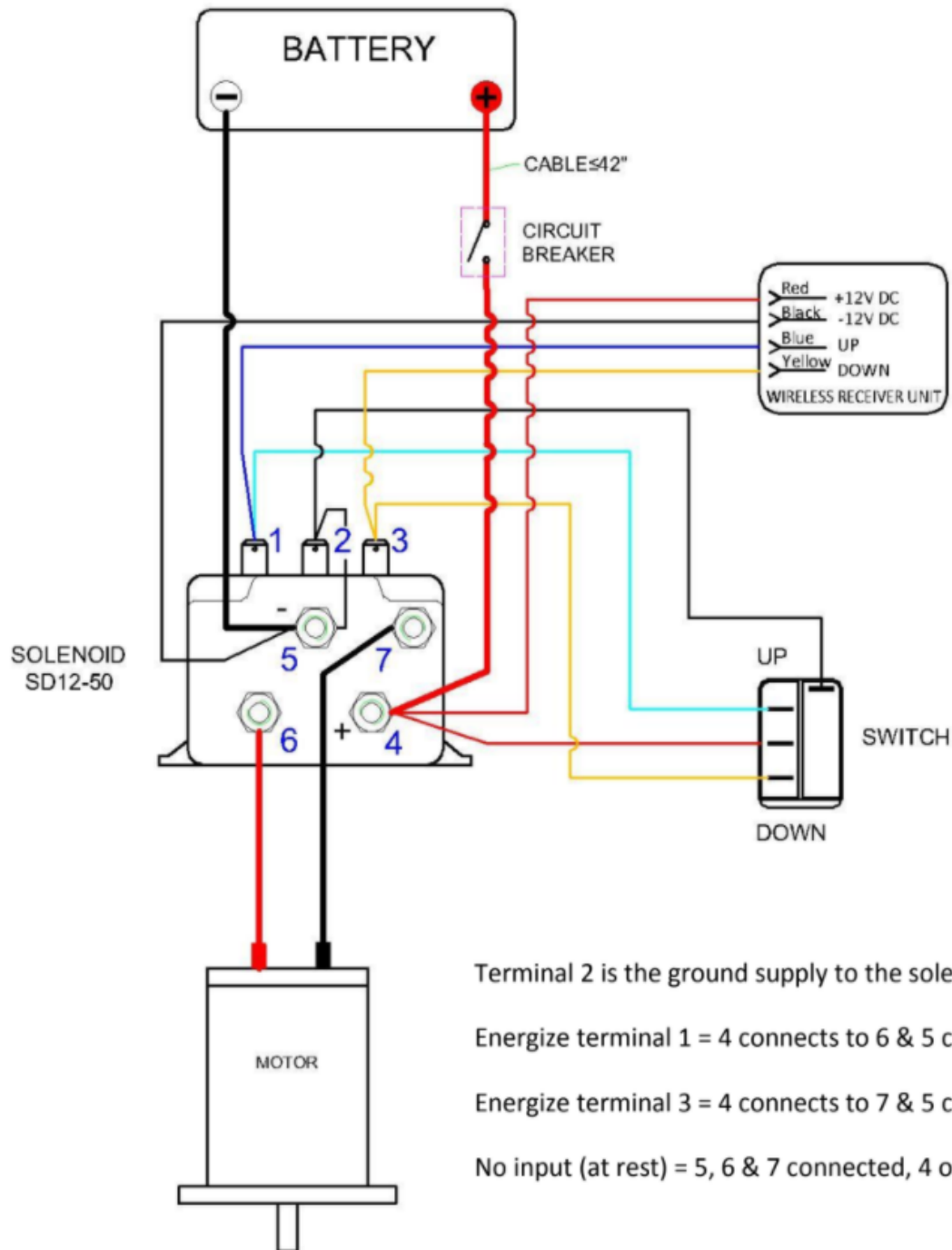

BASIC MAINTENANCE PRACTICES

Although much effort has been undertaken to manufacture the drum anchor winch to make it as durable as possible, the drum anchor winch may be operated in a corrosive environment. It is good practice to wash salt water off *all* running parts with fresh water after every use to avoid corrosion. All other general maintenance practices outlined on pages 4 - 6 apply.



HERO LINE & CHAIN RECOMMENDATION CHART

Please follow the rope / chain configuration below in accordance with your unit and boat size.

Series	Model #	Suggested Boat Length													
		18' - 21'		21' - 24'		24' - 27'			27' - 35'			35' - 45'		45' - 55'	
		1/4" Line	1/4" Chain	5/16" Line	1/4" Chain	3/8" Line	1/4" Chain	5/16" Chain	1/2" line	1/4" Chain	5/16" Chain	5/8" Line	5/16" Chain	3/4" Line	3/8" Chain
HERO	EX-1	250'	10'	175'	10'	125'	10'								
HERO	EX-2	375'	10'	225'	10'	175'	10'		125'	10'					
HERO	EX-3	550'	10'	350'	10'	250'	10'		150'	10'					

HERO PERFORMANCE CHART

Model	EX-1	EX-2	EX-3
Metal Type	Aluminum alloy	Aluminum alloy	Aluminum alloy
Vessel Length	18' - 21'/6m - 7m	18' - 24'/6m - 8m	21' - 27'/7m - 9m
Spool Size	7" (180mm) L x 8" (200mm) diameter.	8" (200mm) L x 9.5" (240mm) diameter.	8" (200mm) L x 11" (280mm) diameter.
(Dc) Power Supply	12v	12v	12v
Circuit Breaker	40 amp	60 amp	60 amp
Motor (Watts)	400w	700w	700w
Motor Size Dia.	75mm	90mm	90mm
Gearbox Size	30AA	44AA	44AA
Max Pulling Load	1,000 lbs/454 kg	1,250 lbs/567kg	1,250 lbs/567kg
Max Recc. Work Load	71 lbs/32 kg	183 lbs/83 kg	151 lbs/69 kg
Net Weight	20 lbs/9 kg	33 lbs/15 kg	35 lbs/16kg
Gross Weight	26 lbs/12 kg	42 lbs/ kg	44 lbs/20 kg



The Patriot *Direct Drive* Series: EZ-1 / EZ-2 Installation Guide

Wiring Diagram for Solenoid SD12-50 & Switch Gear for Winch

ONLY FOR PATRIOT EZ-1 / EZ-2 (see next page for EZ-3)

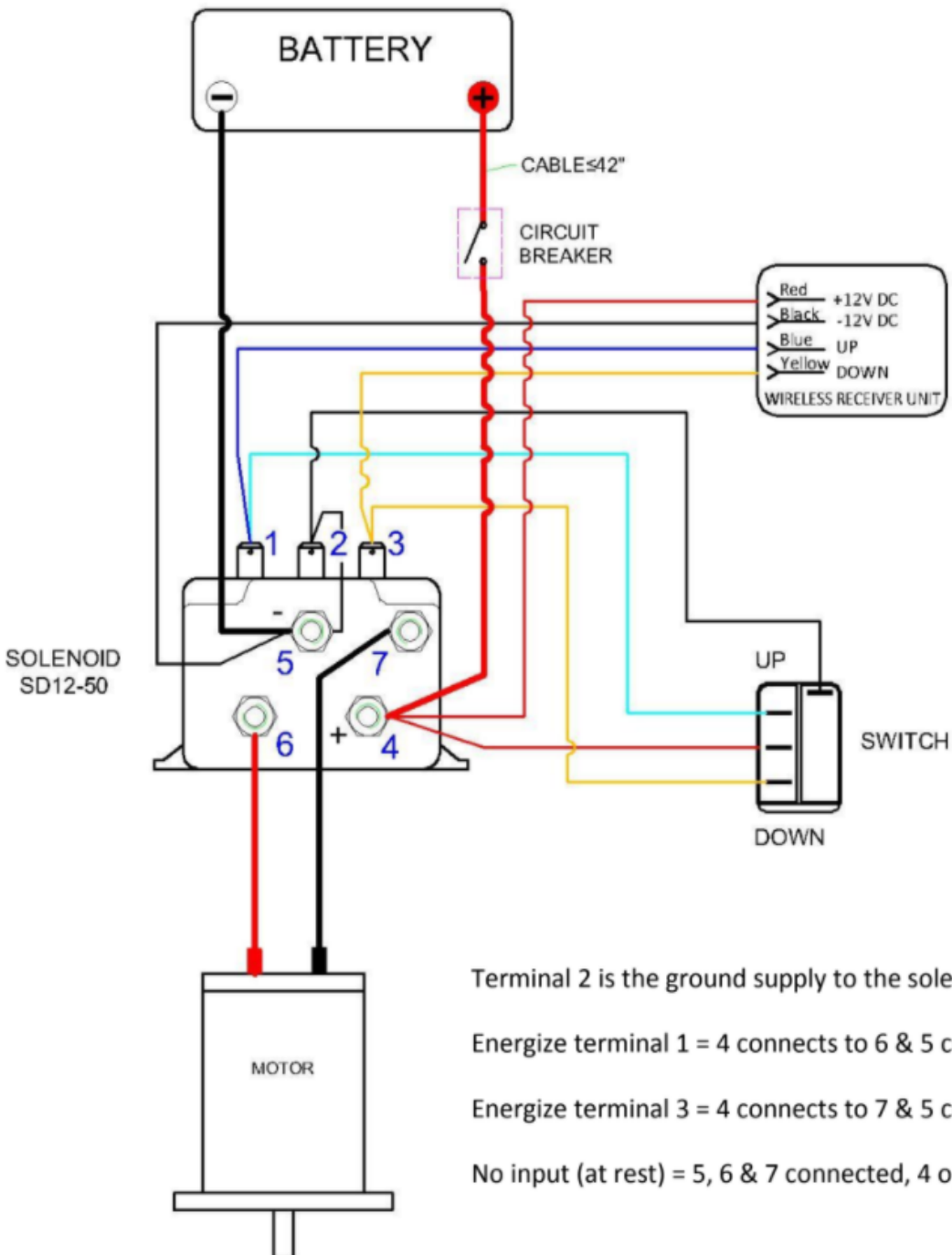

Terminal 2 is the ground supply to the solenoid.

Energize terminal 1 = 4 connects to 6 & 5 connects to 7.

Energize terminal 3 = 4 connects to 7 & 5 connects to 6.

No input (at rest) = 5, 6 & 7 connected, 4 open circuit.

Wiring Diagram for Solenoid SD12-100 & Switch Gear for Winch

ONLY FOR PATRIOT EZ-3 (see previous page for EZ-1/EZ-2)

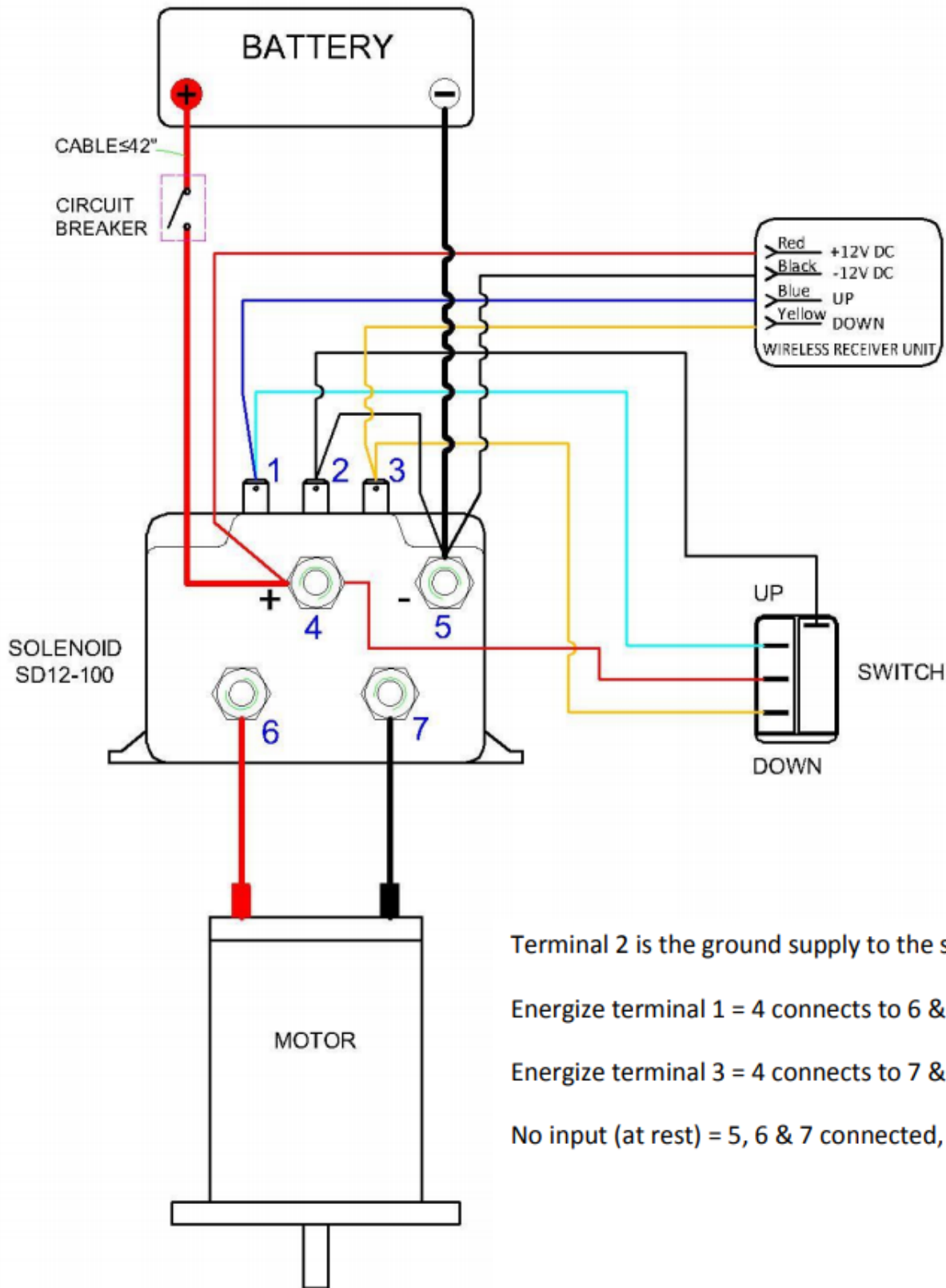

Terminal 2 is the ground supply to the solenoid.

Energize terminal 1 = 4 connects to 6 & 5 connects to 7.

Energize terminal 3 = 4 connects to 7 & 5 connects to 6.

No input (at rest) = 5, 6 & 7 connected, 4 open circuit.

PATRIOT LINE & CHAIN RECOMMENDATION CHART



Please follow the rope / chain configuration below in accordance with your unit and boat size.

Series	Model #	Suggested Boat Length													
		18' - 21'		21' - 24'		24' - 27'			27' - 35'			35' - 45'		45' - 55'	
		1/4" Line	1/4" Chain	5/16" Line	1/4" Chain	3/8" Line	1/4" Chain	5/16" Chain	1/2" line	1/4" Chain	5/16" Chain	5/8" Line	5/16" Chain	3/4" Line	3/8" Chain
PATRIOT	EZ-1	375'	10'	225'	10'	175'	10'		125'	10'					
PATRIOT	EZ-2	550'	10'	350'	10'	250'	10'		150'	10'					
PATRIOT	EZ-3	725'	10'	500'	10'	325'	10'		200'		10'				

PATRIOT PERFORMANCE CHART

Model	<u>EZ-1</u>	<u>EZ-2</u>	<u>EZ-3</u>
Metal Type	316 Stainless Steel	316 Stainless Steel	316 Stainless Steel
Vessel Length	18' - 24'/6m - 8m	21' - 27'/7m - 9m	24' - 30'/8m - 10m
Spool Size	8" (200mm) L x 9.5" (240mm) diameter.	8" (200mm) L x 11" (280mm) diameter.	9" (230mm) L x 12" (305mm) diameter.
(DC) Power Supply	12v	12v	12v
Circuit Breaker	60 amp	80 amp	100 amp
Motor (Watts)	700w	900w	1100w
Motor Size Dia.	90mm	110mm	110mm
Gearbox Size	40SS	40SS	40SS
Max Pulling Load	1,250 lbs/567 kg	1,600 lbs/725 kg	1,850 lbs/840kg
Max Recc. Work Load	181 lbs/82 kg	218 lbs/99 kg	243 lbs/110 kg
Net Weight	42 lbs/19 kg	51 lbs/23 kg	64 lbs/29 kg
Gross Weight	51 lbs/23 kg	59 lbs/27 kg	75 lbs/34 kg



The Rebel *Free-Fall* Series: EZ-4 / EZ-5 / EZ-6 Installation Guide

Wiring Diagram for Solenoid SD12-100 & Switch Gear for Winch

ONLY FOR REBEL EZ-4 / EZ-5 / EZ-6

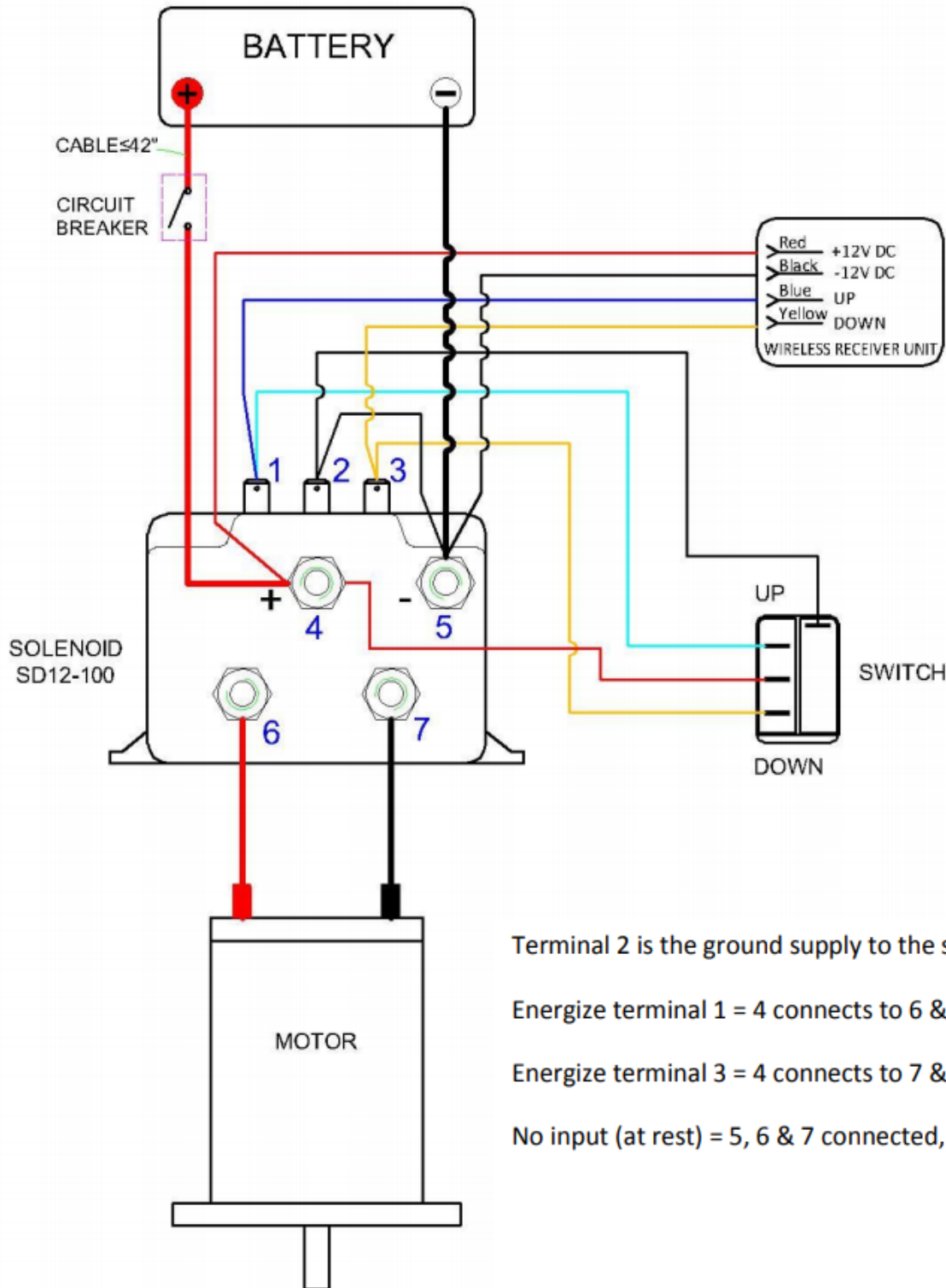

Terminal 2 is the ground supply to the solenoid.

Energize terminal 1 = 4 connects to 6 & 5 connects to 7.

Energize terminal 3 = 4 connects to 7 & 5 connects to 6.

No input (at rest) = 5, 6 & 7 connected, 4 open circuit.

BEST MAINTENANCE PRACTICES

When operating Free Fall drum anchor winches in saltwater may cause the salt to build up around the clutch and brake plates. To avoid the plates becoming stuck, rinse with freshwater after use. All other general maintenance and repair instructions outlined on page 6 apply.



REBEL RECOMMENDED LINE & CHAIN CHART

Please follow the rope / chain configuration below in accordance with your unit and boat size.

Series	Model #	Suggested Boat Length													
		18' - 21'		21' - 24'		24' - 27'			27' - 35'			35' - 45'		45' - 55'	
		1/4" Line	1/4" Chain	5/16" Line	1/4" Chain	3/8" Line	1/4" Chain	5/16" Chain	1/2" line	1/4" Chain	5/16" Chain	5/8" Line	5/16" Chain	3/4" Line	3/8" Chain
REBEL	EZ-4	975'	10'	600'	10'	400'		10'	275'		10'	150'	20'	100'	20'
REBEL	EZ-5	1750'	10'	1100'	10'	800'		10'	425'		20'	275'	20'	175'	20'
REBEL	EZ-6	3000'	10'	1950'	10'	1350'		10'	800'		20'	500'	20'	350'	20'

REBEL PERFORMANCE CHART

Model	<u>EZ-4</u>	<u>EZ-5</u>	<u>EZ-6</u>
Metal Type	316 Stainless Steel	316 Stainless Steel	316 Stainless Steel
Vessel Length	27' - 35'/8m - 11m	35' - 45'/11m - 14m	45' - 55'/14m - 17m
Spool Size	9" (230mm) L x 14" (355mm) diameter	11" (280mm) L x 16" (405mm) diameter	14" (355mm) L x 18" (455mm) diameter
(Dc) Power Supply	12v	12v	12v
Circuit Breaker	100 amp	120 amp	120 amp
Motor (Watts)	1100w	1250w	1250w
Motor Size Dia.	110mm	130mm	130mm
Gearbox Size	40SS	63SS	63SS
Max Pulling Load	1,850 lbs/840 kg	2,000 lbs/907 kg	2,000 lbs/907 kg
Max Recc. Work Load	203 lbs/92 kg	204 lbs/ 92 kg	214 lbs/ 97 kg
Net Weight	75 lbs/34 kg	108 lbs/49 kg	121 lbs/55kg
Gross Weight	88 lbs/40 kg	123 lbs/ 56kg	141 lbs/ 64 kg

WINCH INSTALLATION INSTRUCTIONS *ONLY FOR REBEL SERIES

*Refer to page 5 for the Hero and Patriot Series Instructions

Depending on the motor/gearbox position, this drum anchor winch needs to be either overfed or underfed (i.e. spooled over or under the shaft). The red arrows below indicate the direction of feed rope rotation:

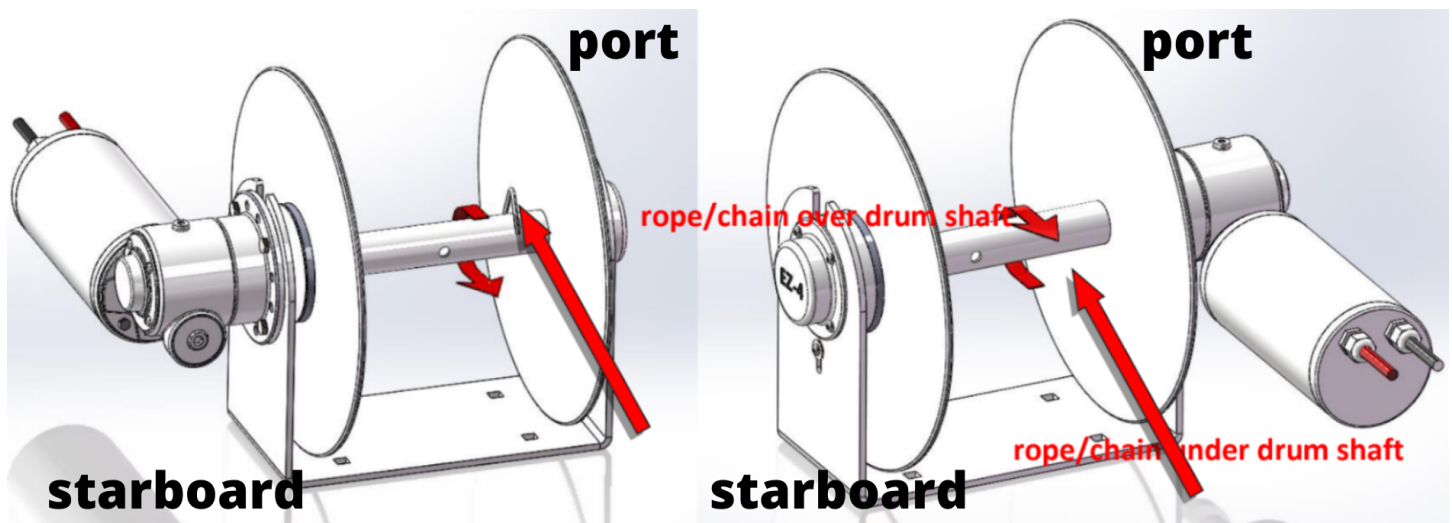

For example - Installing the Rebel winch with the gearbox and motor on the **port** side will require the rope to be spooled from underneath (underfed) in order for free-fall to work. **The port side is the side of the vessel which is to the left of an observer aboard the vessel and facing the bow, that is, facing forward toward the direction the vehicle is heading when underway, and starboard is to the right of such an observer.** **If**, however, you plan to **permanently** convert the Rebel to a direct drive unit, these instructions do not apply.

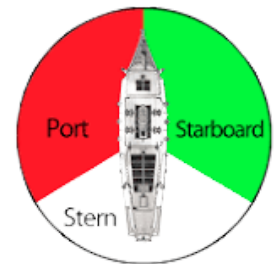

Explaining Free-Fall:

E-Z Anchor Puller's Rebel Series (EZ-4, EZ-5, EZ-6) is our larger, *true* free-fall series.

We say it is "true" free-fall because, unlike other anchoring solutions on the market who have free-fall capabilities in instances of emergency (a boat's loss of power, a stuck anchor, etc.) our units are manufactured to free-fall for regular, recreational and/or commercial use with deep waters in mind. The Rebel free-fall drum anchor winch will deploy your anchor as fast as gravity will allow it.

Your Rebel Series (EZ-4, 5 or 6) comes to you in a free-fall mode. The free-fall works because of a clutching mechanism (on the opposite side of the gearbox and motor). This consists of a clutch plate that has a metal pin that sticks out of it, which hits the clutch block (geometric-shaped block below the clutch plate). To operate the Rebel series, press the down button for 2 seconds, then release it. Your anchor will be deployed as fast as gravity allows it to go. **DO NOT ATTEMPT TO STOP YOUR ANCHOR MID-FREEFALL.** Doing so will cause irreparable damage to your anchor winch, and may cause serious injury. Once your anchor is set and you have let out your scope, press the "up" button to rotate the clutch plate to spin toward the spool to clamp it tight. You are now held at anchor. When you are ready to move from that location, press the "up" button and hold it until your anchor is fully retrieved.

WARNING! DO NOT PUT A PIN INTO THE DRUM SHAFT WHEN INSTALLING!

See the **Converting Your Rebel Into a Direct Drive Unit section below**

CONVERTING YOUR REBEL INTO A DIRECT DRIVE UNIT : There are two options if you wish to use your Rebel EZ-4, EZ-5 or EZ-6 as a direct drive unit, depending on whether you prefer to use it in Direct Drive some of the time or as a permanent solution.

PERMANENT CONVERSION TO DIRECT DRIVE : If you know when you receive it that you want to use the unit in direct drive and **NEVER** in free-fall, the best way to make the winch direct drive is to put a **3/8" bolt through the spool and shaft and tighten it with a nut before you put the rope on**. Then on the side opposite the gearbox and motor, lower the block so that the pin in the clutch plate *cannot* make contact with the block.

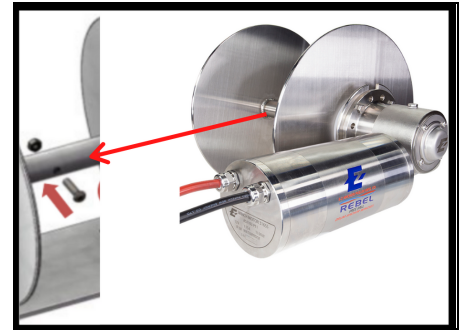

PART-TIME /TEMPORARY CONVERSION TO DIRECT DRIVE :

When the clutch plate is tight against the spool, simply lower the clutch block so that the pin in the clutch plate cannot make contact with the block and it will be direct drive. If you decide you want to go back to free fall, you would just need to raise the clutch block so the pin makes contact with the block and it is then able to be used in free fall again.

REBEL EMERGENCY FREE-SPOOL INSTRUCTIONS : If your boat should lose all power and you need to deploy the anchor, there is an emergency free spooling feature that will allow you to do so. In order to do so, simply take off the end cap of your gearbox and remove it's shaft key on the side of the gearbox by unscrewing the large screw, which will back out the drive key along with the bushing. Then retrieve the anchor rope.

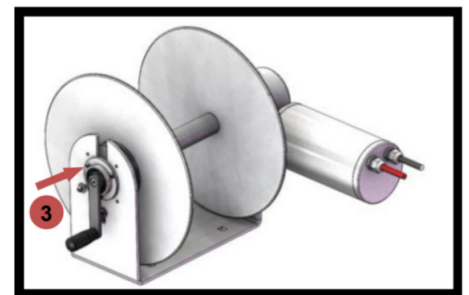
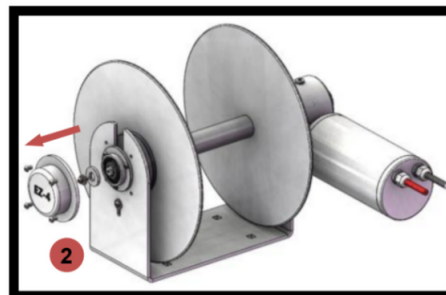
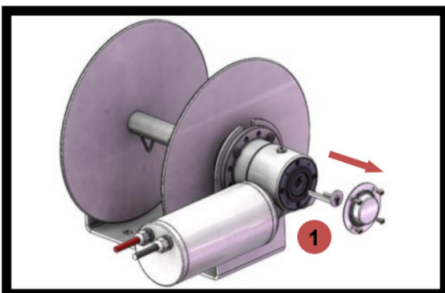

**To retrieve the anchor while there is no power, pull the anchor line in by hand, then use the included crank handle to wind the rope back onto the drum

Step 1.**

Take off the end cap and washer/bolt on the side of the gearbox by removing the large screw

Step 2.

Take off the end cap and washer/bolt on the *opposite* side of the gearbox by removing the screw.

Step 3.

Attach & tighten the crank handle to the shaft on the *opposite* side of the gearbox, then turn the handle crank to put your rope back onto the spool.

COMMON TROUBLESHOOTING QUESTIONS FOR THE REBEL SERIES*

*to see the general troubleshooting list, refer to page 8.

Issue	Possible Cause(s)	Solution(s) *numbers correlate to each other
The Pin is not hitting the block at all / hitting the block properly	<ol style="list-style-type: none"><li data-bbox="630 323 976 359">1. The block is not raised<li data-bbox="630 394 976 569">2. There is no pin for the block to touch or the pin is stuck or damaged or the spool has moved	<ol style="list-style-type: none"><li data-bbox="1062 323 1507 579">1. The block is supposed to be held by a screw, but sometimes the screw is loose, making the block fall. Unscrew the block, push it up closer to the pin, then screw it back in.<li data-bbox="1062 625 1507 814">2. The pin may have become loose and has become misplaced or lost. Please call 1.800.800.1640 for a replacement kit immediately.
The Unit will not Free-Fall	<ol style="list-style-type: none"><li data-bbox="630 852 976 926">1. The clutch pin is not hitting the clutch block<li data-bbox="630 972 976 1045">2. There is a bolt through the drive shaft	<ol style="list-style-type: none"><li data-bbox="1062 852 1511 1041">1. The clutch block has been lowered into temporary free-fall. Raise your block so the pin does come into contact with the block.<li data-bbox="1062 1052 1511 1440">2. Unfortunately, putting a bolt through the shaft of your Rebel anchor winch makes it a permanent direct drive. If you want to go back to free-fall, you must remove all rope and chain from the spool and remove the bolt that's holding the spool and drive shaft together.

WARRANTY INFORMATION

****The agreement entered when you make an E-Z Anchor Puller purchase is subject to the following conditions limitations:**

*****The warranty period begins on the date the invoice is generated and the written agreement is received.
The warranty **CANNOT** be honored if the appropriate documentation has not been provided or if it is incomplete.
See the next page for warranty form & instructions*****

- **7-year warranty** for **recreational** vessel usage on winch motors and gearboxes w/ 3-year warranty on solenoids, switches, circuit breakers and fast fall systems
- **3-year warranty** for **commercial** vessel usage on winch motors and gearboxes w/ 1-year warranty on solenoids, switches, circuit breakers and fast fall systems.
 - Both warranty agreements include replacement of faulty part(s) materials and/or workmanship

- The Product(s) sold must be free from defects in the materials, workmanship and packaging

- If you suspect the product(s) of being defective in workmanship or materials upon purchase, stop using the product(s) & contact E-Z Anchor Puller at **1.800.800.1640** to report the defect within 7 days within inspection.

Purchaser understands that they are responsible for any/all charges associated with removal, returning the faulty goods to E-Z Anchor Puller for warranty claim and reinstallation;

- Any damage sustained to any vessel, property or equipment or persons due to the installation or use of a E-Z Anchor Puller product, as far as is permitted by consumer law, is excluded from this warranty;

- No representative or agent of E-Z Anchor Puller has the authority to make any decisions or agreements regarding warranty with you without the prior agreement with E-Z Anchor Puller Mfg. Co., LLC. directly; This warranty shall be limited or null and void if any of the following occur:

- The improper installation of a E-Z Anchor Puller, including not adhering to the installation guidelines contained within this manual;

- The improper and irregular maintenance, repair or service of your E-Z Anchor Puller product;

- The improper use or incorrect application of your E-Z Anchor Puller product;

- Improper modification/s made to the E-Z Anchor Puller; The warranty does not cover any loss, damage, harm or claim associated with or as a result of an accident or natural disaster.

- If you are unsure about anything contained in this document please contact E-Z Anchor Puller for clarification.



E-Z ANCHOR PULLER MFG. CO.
 America's Anchor Winch Since 1990



To be eligible for warranty protection please complete this form within 90 days of purchase & post to:

support@ezanchorpuller.com

Purchaser Info:

Company: _____ Name: _____

Address: _____

City: _____ State: _____ Zip: _____

Email Address: _____ Cell Phone #: _____

Supplier / Installer Info:

Company: _____ Name: _____

Address: _____

City: _____ State: _____ Zip: _____

Email Address: _____ Cell Phone #: _____

(Circle One): EX-1 / EX-2 / EX-3 / EZ-1 / EZ-2 / EZ-3 / EZ-4 / EZ-5 / EZ-6

Boat Manufacturer: _____ Boat Model & Length: _____

Gauge of Battery Wire: _____ Distance from Battery: _____

Date Received: _____ Date Installed: _____

You must include a copy of the invoice / receipt for the drum anchor winch or the boat if the drum anchor winch came installed from a dealer. Failure to register the motor's serial number will void the warranty!

Motor Model #: _____

Motor Serial Number: _____