

SWAG AIR-HYDRO RAM MOUNT ASSEMBLY INSTRUCTIONS



Tools needed for assembly:

- ✓ Welder
- ✓ Drill & Bits
- ✓ Basic Hand Tools.

If you purchased the welded assembly your kit is 98% ready out of the box and proceed to step #2. If not proceed to the next step. Weld up both saddle brackets and tube support bracket as shown below.

Note: The tube support gussets have tabs that key into position. If you own a JMR, Pro Tools Bender and or JD2 Model 32 bender center up the 1.25" dia tube between the tube support gussets. If you own a JD2 Model 3 bender the 1.25" dia tube will sit flush with the edge of the tube support gussets see the 2nd picture below.

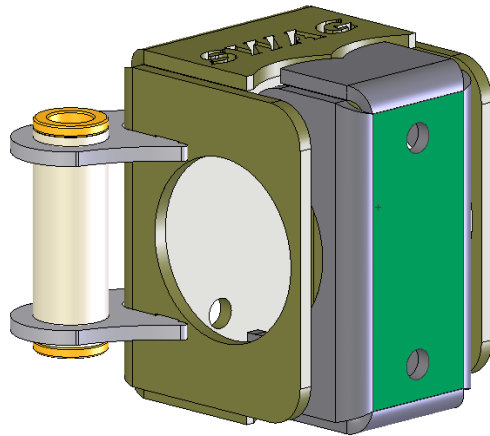

JMR/Pro Tools/Woodward Fab/Eastwood Fab/JD2 Model 32↑

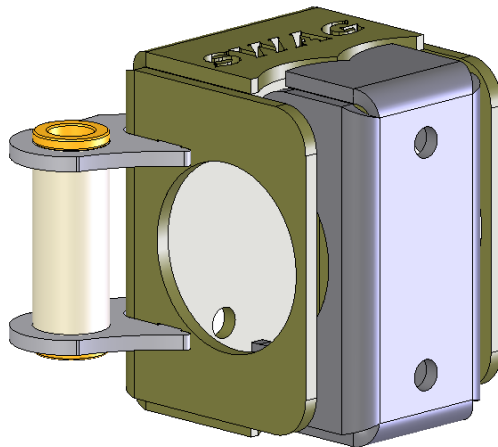

JD2 Model 3 ↑

Finished welded assembly show below with bronze bushings inserted into 1.25" dia tube.



Step #2

Press out the cross pin, install the machined thumb knob and reinstall cross pin as shown below.

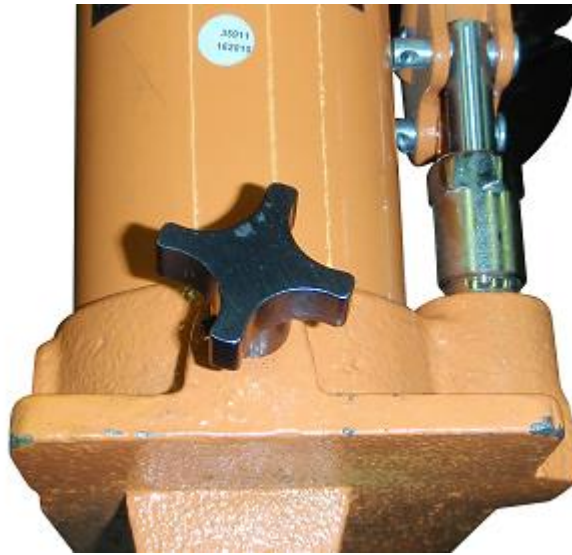

Step #3

Install the ram as shown below. Use the provided shaft collar to center up the ram in the middle of the 5/8" dia tube and torque the 1/2" bolts down 70 ft/lbs. Because it is a tight fit it is best to use a bench vise to press the tube through the shaft collar.

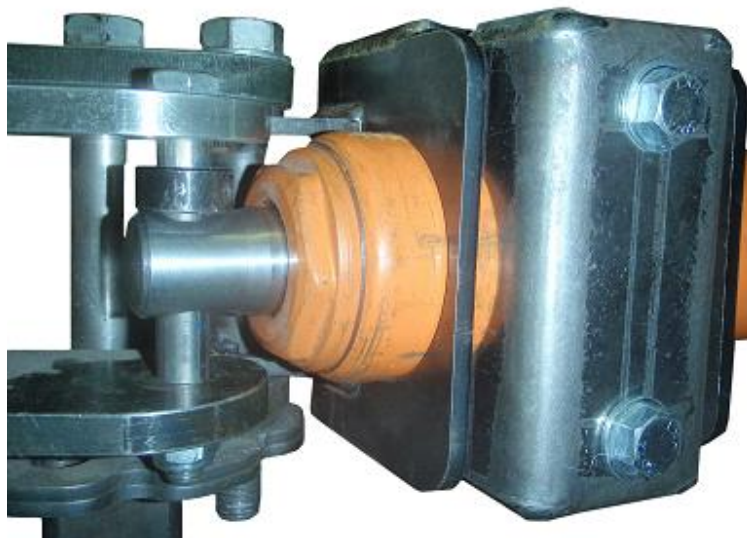

Step #4 for JD2 Model 32 owners only.



If you own a JD2 Model 32, assemble the fasteners as show below with the bronze bushings going through the welded tube as well as through the tube bender arms. This will neck down the holes in the tube bender arms to the proper diameter.

Install the tube bender arm extension plates as shown in the picture below. The 1.0" dia tube are designed to be a press fit into the provided plates. Tighten bolt up to 20 ft/lbs Continue on to step #3 above.

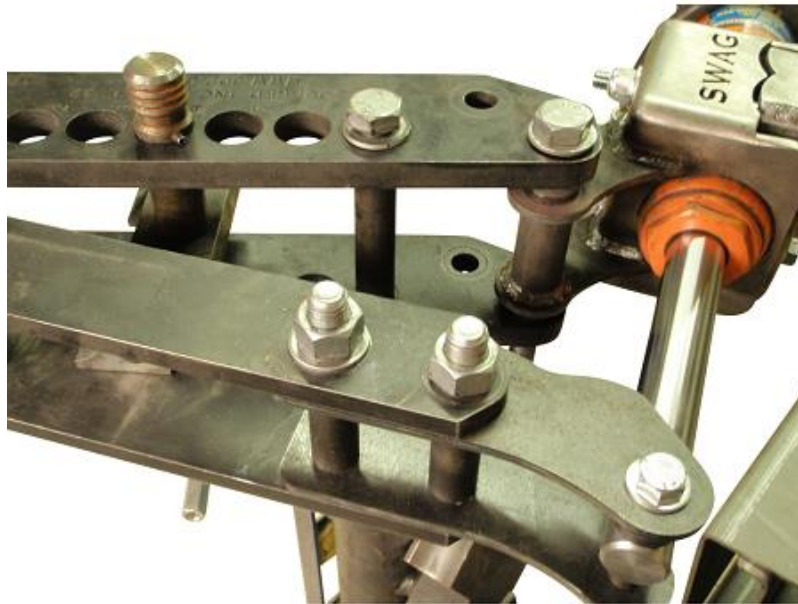

If you are having problems with the ram not providing enough stroke length to move your die set to the next hole position, make sure the ram is bled and full of jack/hydraulic oil. The rubber fill plug is located on the side of the body about half way up the metal housing.

Wear safety glasses and keep you fingers out of harms way.

The jack will only work with the thumb knob pointed up, if jack fails to work fill the jack with oil by pulling out the rubber plug along the side of the body.

Thanks for the order, and be sure to visit Swag Off Road on [Facebook](#).

