



COOKOUT™

22.5" CHARCOAL KETTLE



ASSEMBLY INSTRUCTIONS & USER MANUAL

CO-600CG (C30504) Charcoal

LIMITED 2-YEAR WARRANTY

Read and save manual for future reference.

Assemble your grill immediately. Missing or damaged parts should be claimed within 30 days of purchase.

For product inquiries, parts, warranty and troubleshooting support, please call 1-800-249-2506.



COOKOUT™ 22.5" CHARCOAL KETTLE

STOP

DO NOT return this product to the store.

IF YOU NEED HELP OR PARTS, CALL THE COLEMAN® HOTLINE:

1-800-249-2506

HOURS: 9AM-7PM EST Mon-Fri, CLOSED Saturday and Sunday

Assemble your **COOKOUT™ CHARCOAL KETTLE** immediately.
Missing or damaged parts must be claimed within 30 days of purchase.

FOR OUTDOOR USE ONLY

CHARCOAL KETTLE SAFETY CHECK

FOR YOUR FAMILY'S SAFETY, PLEASE CHECK THE FOLLOWING:

- Read and follow all safety statements, assembly instructions, use and care directions before attempting use this product.
- This manual should be kept with the charcoal kettle at all times.
- PERFORM LEAK TEST** on all connections as specified in this user manual. Leak checks should be performed on all new griddles even if assembled by an assembler or gas technician. Leak checks should be performed frequently thereafter.
- Failure to follow all of the manufacturer's instructions could result in hazardous fires, explosions, property damage, or serious personal injury or even death.

CAUTION

IN DIRECT SUN, AND IN OPERATION, YOUR CHARCOAL KETTLE'S STAINLESS STEEL AND PAINTED STEEL PARTS CAN BECOME VERY HOT.

TABLE OF CONTENTS

Danger	4
Safe Usage	4
Lighting Instructions	5
Operating Instructions	7
Putting Out the Fire	8
Ash Removal	8
Maintenance and Storage	9
Cooking Tips	10
Hardware Pack	11
Parts List	12
Exploded Diagram	13
Assembly Instructions	14
Warranty & Service	24

DANGER

- **Burning charcoal gives off carbon monoxide. Do not burn charcoal inside homes, garages, tents, vehicles or any enclosed areas.**
- Keep children and pets away from the **charcoal kettle** when operating.
- Never leave the charcoal kettle unattended while in use.
- **Minimum clearance to adjacent combustible materials:
Minimum of 36" (91.44 cm) from furthest protruding edge on all sides of the COOKOUT™ Charcoal Kettle**
- Keep the charcoal kettle on a secure, level surface at all times.
- Do not operate the charcoal kettle under any overhead construction, such as; roof coverings, carports, awnings or overhang.

SAFE USAGE

- Do not move the charcoal kettle when hot or in operation.
- Do not locate in windy settings. High winds adversely affect cooking performance.
- Do not use gasoline, alcohol, lighter fluid, or other highly volatile fluids to ignite charcoal.
- Do not remove ashes from the ash collection until charcoal is completely extinguished and cooled.
- Keep the lid closed during the preheat period, with vents fully opened.
- Never touch the cooking grate, charcoal grate, the charcoal, ash catcher, or the exterior of the charcoal kettle during or after use.
- Only put charcoal on the charcoal grate. Do not place charcoal directly into the fire bowl, ash catcher or on the cooking grate.
- Grill mitts should always be worn while cooking, adjusting air vents, adding charcoal, and handling the lid. Use proper grill tools, with long, heat-resistant handles.
- Do not use water to control flare-ups or to extinguish charcoal, as it may damage the porcelain finish. Close air vents and replace the lid to extinguish charcoal.
- To control flare-ups, slightly close the vents. To completely extinguish fire, close all vents and lid completely.
- Do not remove ashes from ash catcher until all charcoal is completely burned out and fully extinguished. Allow ample time to cool.

LIGHTING INSTRUCTIONS

We recommend using a chimney charcoal starter, electric charcoal starter, lighting cubes or newspaper to light charcoal. **DO NOT USE LIGHTER FLUID.**

WARNING

For proper air flow, remove accumulated ashes from the ash catcher, only after the coals are fully extinguished.

CHIMNEY CHARCOAL STARTER INSTRUCTIONS

NOTE: If using a chimney charcoal starter, follow the instructions provided with your starter for best results.

1. Remove the lid, cooking grate and open all air vents before building the fire. Charcoal requires oxygen to burn, so be sure nothing blocks the vents.
2. With the charcoal grate in position, turn the chimney charcoal starter upside down, and place newspaper in the bottom portion.

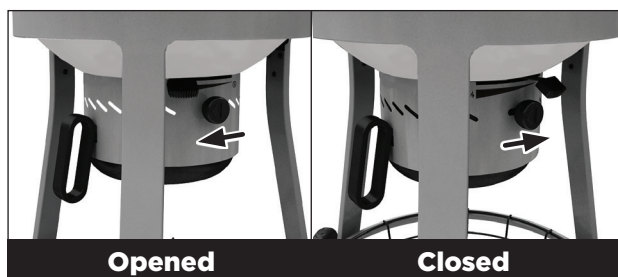
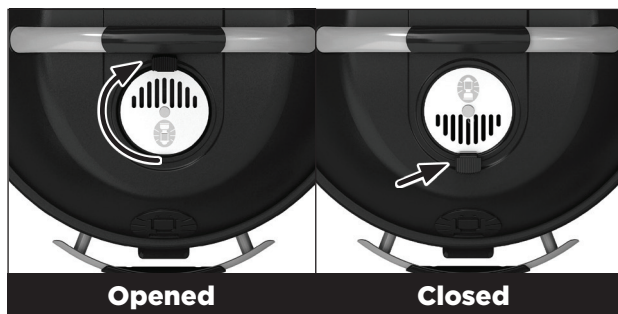

3. Place the chimney charcoal starter into the center of the charcoal grate, in the upright position.
4. Fill the top half of the chimney charcoal starter with charcoal.
5. Using a lighter, ignite the newspaper through the holes provided in the bottom of the chimney charcoal starter.
6. Leave the chimney charcoal starter on top of the charcoal grate with the **lid removed**.

7. **READY:** The briquettes are ready when the coals are covered with a light grey ash. This usually takes 25 to 30 minutes.



8. With a heavy, long sleeved grill mitt, carefully empty the hot coals, from the chimney charcoal starter onto the charcoal grate.
9. Arrange the coals into an even layer using long cooking tongs, or pile the coals in the middle of the grate, if both direct and indirect heat is needed.

FLAVOUR TIP: For additional smoky flavour, add moistened flavoured hardwood chips (pre-soaked) directly on the coals before you begin cooking.

10. Re-position the cooking grate, **close the lid and allow the charcoal to burn.**
11. Wait for the cooking grate to preheat, before adding food.
12. Re-position the lid and ensure that the air vents are open.
13. Consult your recipe for recommended cooking times. Use a temperature probe to check doneness.

LIGHTING INSTRUCTIONS

USING LIGHTER CUBES OR CRUMBLED NEWSPAPER FOR LIGHTING

1. Place either lighter cubes (which are non-toxic, odorless and tasteless) or crumpled newspaper into the center of the Charcoal grate.
2. Pile the charcoal briquettes into a pyramid shape directly over the lighter cubes or newspaper.
3. Using a lighter, light the lighter cubes or newspaper.
4. Once fully lit, close the lid and allow the charcoal to burn.
5. Follow step 8-14 as shown on page 5.

HOW MUCH CHARCOAL IS REQUIRED?

- Approximately 50 briquettes (1.5 kg / 3.3 lb).
- Charcoal recommendations are approximate. Longer cooking times, cold or windy temperatures will require that additional charcoal be added to reach and maintain ideal cooking temperatures.

ADDING CHARCOAL DURING COOKING

⚠ WARNING

Always wear protective gloves. Always use long handled heat resistant tongs for loading additional charcoal.

1. Remove the COOKOUT™ lid and hook it on the side of the COOKOUT™ fire bowl.
2. Move food to one side of the cooking grate.
3. To access the charcoal grate, lift the hinged portion of the cooking grate.
4. Load approximately 12-20 additional briquettes (390 g - 520 g / 0.86 lb - 1.15 lb) for each additional hour of cooking required.





⚠ ATTENTION

Never leave your charcoal kettle unattended while in use.

OPERATING INSTRUCTIONS

Oxygen is an essential part of building a proper fire, elevating and stabilizing cooking temperatures and controlling cooking times. The COOKOUT™ Charcoal Kettle comes equipped with three air intake controls.

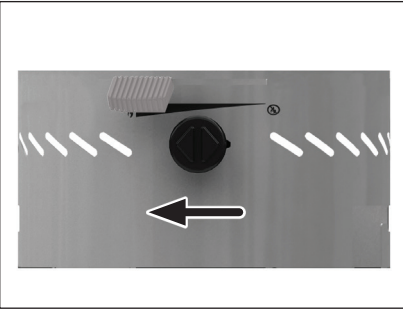
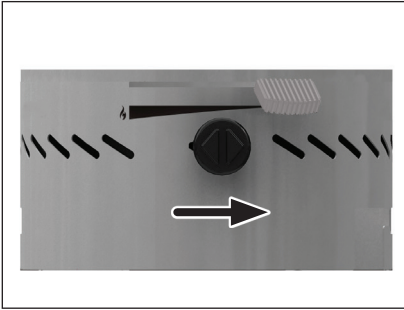
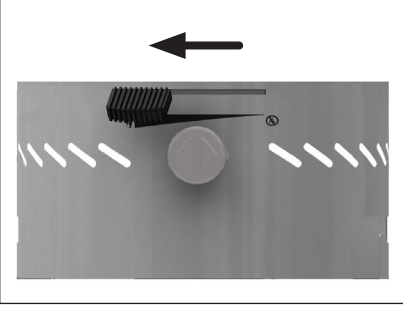
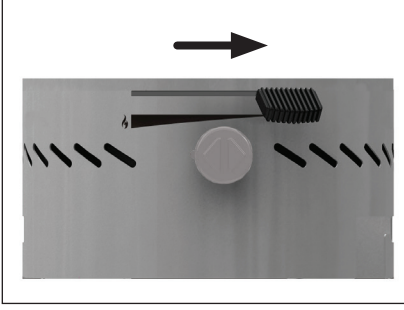
FEATURES	LIGHTING & COOKING During lighting and operation all vents should be in the OPEN position. More air increases the burning temperature of the coals.	SHUT DOWN Closing the vent either partially or completely will help to cool down the coals. Less air decreases the burning temperature.
<p>COOKOUT™ Lid Vent</p>		
<p>COOKOUT™ Fire Bowl Vent</p>		
<p>COOKOUT™ Ash Sweep The Ash Sweep functions as both a cleaning tool for eliminating ash from the firebowl, and also an air intake control while cooking.</p>		

PUTTING OUT THE FIRE

Once cooking is complete, follow these steps to extinguish the fire:

1. Using protective gloves, close the COOKOUT™ lid.
2. Close all vents.

NOTE:

Assume that it will take at least 1 hour for your charcoal to extinguish and your charcoal kettle to cool down. There is not an ON or OFF switch for a charcoal fire. Always be cautious about making any assumptions about when the fire is completely out and completely cool.

⚠ WARNING

- o Do not store your charcoal kettle until ash and coals are fully extinguished.
- o Allow charcoal to burn out before removing from the charcoal kettle to avoid a possible fire.
- o Never dump hot coals where they might be stepped on or be a fire hazard.
- o Never dump ashes or coal before they are fully extinguished.

ASH REMOVAL

Remove ash catcher, only after the charcoal has been extinguished and allowed to cool.

TIP:

A pile of ash left in the ash catcher can collect moisture and make cleanup a challenge. Clean the ash catcher after every use.

1. Ensure that the ash catcher is in position.
2. Ensure that the fire bowl vent is closed.

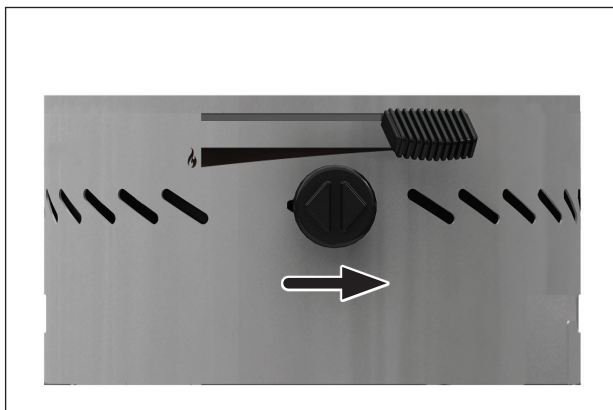

3. Once you are sure that the ash has cooled, remove the COOKOUT™ lid, and cooking grate.
4. Sweep all ash and debris from the charcoal grate into the lower fire bowl. Dispose of any larger pieces of charcoal.

5. Grasp the ash sweep handle and move back and forth until most of the ash is swept into the ash catcher. Use a hand broom for any leftover residue in the fire bowl.

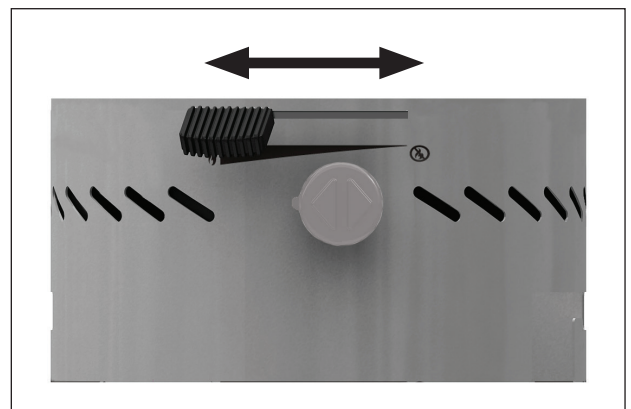

6. With your heat resistant ash container handy, remove the ash catcher from its position and carefully dump all ashes into a heat resistant container. Allow it to sit for 24 hours.



MAINTENANCE AND STORAGE

Before storing your Coleman® COOKOUT™ Charcoal Kettle, give it a thorough cleaning. Follow the care and maintenance instructions outlined below.

GENERAL MAINTENANCE

ATTENTION

- o DO NOT USE ANY ABRASIVE CLEANERS OR STEEL WOOL on cooking or charcoal grate or any painted, porcelain or stainless steel parts.
 - o Porcelain enamel components must be handled with additional care. The baked-on enamel finish is glass-like, and will chip if struck.
-

FIRE BOWL AND LID

- Use a plastic paint scraper to remove build-up, food residue and ash from inside the charcoal kettle fire bowl and lid.
- If necessary, wash the interior and exterior of the charcoal kettle lid and fire bowl with a warm detergent and water solution. Always rinse and dry thoroughly before re-installing parts.
- Spray a light coating of vegetable cooking spray on the interior surfaces of your charcoal kettle for added protection, only when cool.

ASH CATCHER

- Always wait for ash and grease to cool before removing the ash catcher and dumping in a non-combustible container.
- Wash the ash catcher with soap and water, rinse and dry thoroughly before replacing.

COOKING GRATE

- Always perform a burn-off and clean-up with your brass grill brush, at the START of your cooking session, during preheat. Leftover oil on your cooking grate will help to protect it in between cooking sessions.
- If necessary, wash cooking grate with soap and water. Do not immerse grate in water.
- Rinse and dry thoroughly with a towel.

STORAGE

- Once all surfaces are clean and dry, cover your charcoal kettle with a full length cover to protect surfaces from dirt and moisture. If storing for long periods, it is recommended to remove the cooking grate and charcoal grates and store in a dry place.
- If storing your charcoal kettle in a garage or on a concrete floor, it is recommended to place a large piece of cardboard underneath the charcoal kettle to protect from moisture.
- Always store charcoal in a cool, dry place.

COOKING TIPS

- All vents must remain OPEN during lighting and cooking.
- Meat thermometers help you make sure that meats are cooked to the desired temperature.
- Prevent food from sticking and protect your grates from moisture by spreading vegetable oil or shortening on a COLD, UNLIT cooking grate.
- Trimming fat from meat helps to avoid flare-ups and makes for healthier food.
- Apply sauces at the end of the cooking.
- Leave space around each food item on the grate to allow for even cooking and smoke penetration.
- Turn meat just once on the grill. For steaks, turn them when the juices start to bubble on the uncooked side. The clearer the juice, the more well-done the meat.
- Avoid cross contamination. Use separate trays for uncooked and cooked food.
- Brush the grilling surface (once it's cooled) with a wired brush to remove any stuck on food.
- If the charcoal is damp or wet, we recommend discarding it, as the performance will be drastically reduced.

NOTE:

Assume that it will take at least 1 hour for your charcoal to extinguish and your charcoal kettle to cool down. There is not an ON or OFF switch for a charcoal fire. Always be cautious about making any assumptions about when the fire is completely out and completely cool.



WARNING

For your families safety, do not attempt to light the charcoal kettle until you have reviewed this manual.



WARNING

Lid, lid handle and fire bowl may be hot to the touch. Always wear protective, heat resistant grilling gloves while using your COOKOUT™ charcoal kettle.

HARDWARE PACK

TOOLS NEEDED FOR ASSEMBLY

- #2 Phillips screwdriver (long and short)
- Pliers

For correct hardware assembly, always position the lock washer between the screw and the flat washer.

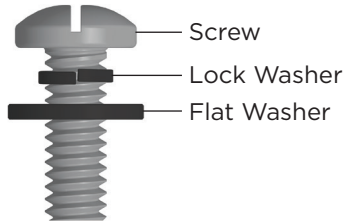

No.	Description	Part Number	Qty.
1	NO.10-24UNC X10 Screw	20124-10010-250	20
2	ST4.2X6 Tapping Screw	24200-42006-137	1
3	Screw for vent	G531-0048-9081	2
4	φ6.5 Washer	G466-0042-9000	8
5	Spacer	G501-0033-9100	4
6	No.10 Wing Nut	33324-10000-810	4
7	Compression Spring	G528-0058-9000	2
8	Hitch Pin	G515-0013-9000	2
9	NO.10-24UNC X 13 Screw	20124-10013-250	3
10	M10 Nut	33401-10000-037	1

⚠ Caution:
Sheet metal can cause injury. Wear gloves when installing the grill.

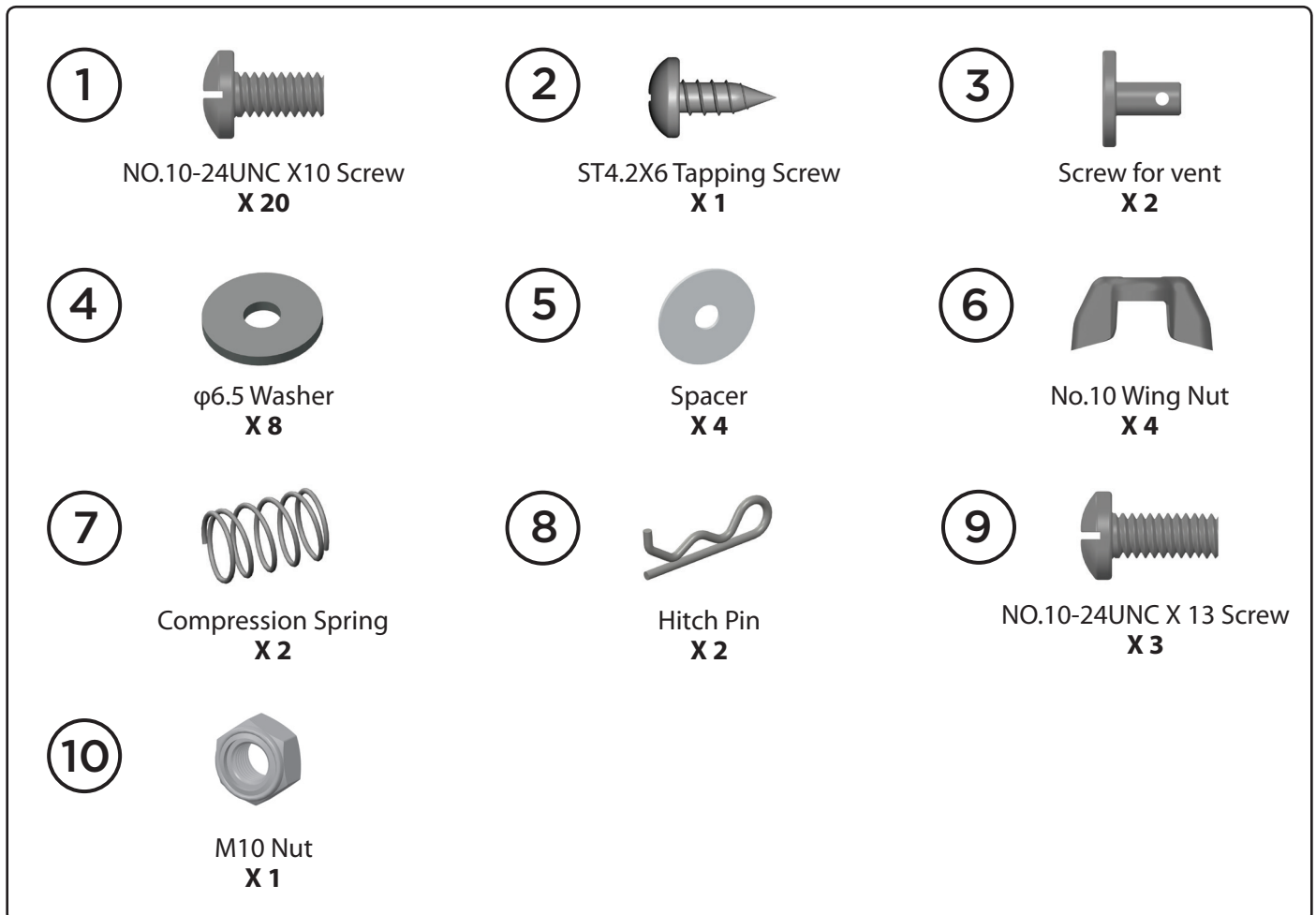

BEFORE ASSEMBLING THE CHARCOAL KETTLE, READ THESE INSTRUCTIONS CAREFULLY.

Assemble the charcoal kettle on a flat, clean surface.

PARTS LIST FOR CO-600CG (C30504)

Item No.	Qty.	Description	Part No.
AA	1	Lid	C305-0026-01
AB	1	Lid handle	C305-2800-01
AC	1	Lid vent	G537-0029-01
BA	1	Fire Bowl	C305-0201-02
BB1	1	Ash Sweep	C305-0006-02
BB2	1	Ash Sweep Handle	G531-0047-01
BC	1	Cooking grate	C305-0300-01
BD	1	Charcoal grate	C305-0007-02
BE	1	Front Handle	C305-0900-01
CA	1	Fire Bowl Vent	C305-0400-02
CB	1	Fire Bowl Vent Handle	C305-0009-01
CC	1	Inner vent	C305-0008-01
CD	1	Ash catcher	C305-0010-01
CE	1	Ash catcher Handle	C305-0011-01
DA	1	Upper cart ring	C305-0500-01
DB	1	Lower cart ring	C305-0800-01
DC	1	Cart leg, front	C305-0014-01
DD	1	Left Cart leg, rear	C305-0600-01
DE	1	Right Cart leg, rear	C305-0700-01
DF	1	End cap, front cart leg	C305-0016-01
DG	1	Bottom Shelf	C305-0015-01
DH	2	Wheel	E202-0013-01
DI	2	Wheel cap	E202-0016-01
DJ	1	Wheel axle	C305-0019-01
F1	1	Hardware pack	C305-B004-01
F2	1	Manual	C305-M004-01

EXPLODED DIAGRAM FOR CO-600CG (C30504)



Extras	
Hardware Pack F1	Manual F2

ASSEMBLY INSTRUCTIONS

1

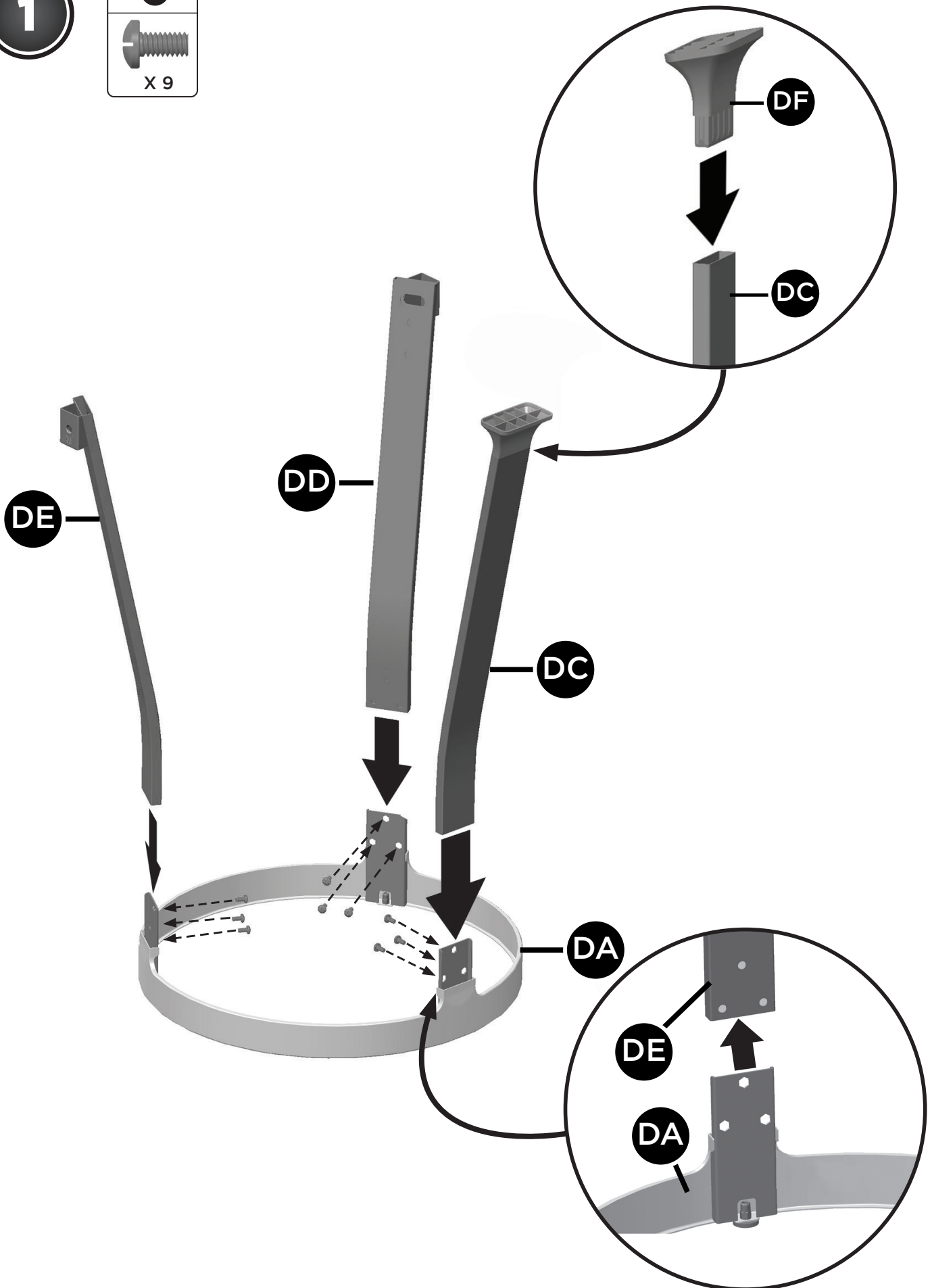
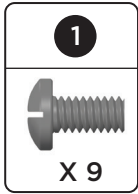

ASSEMBLY INSTRUCTIONS

2

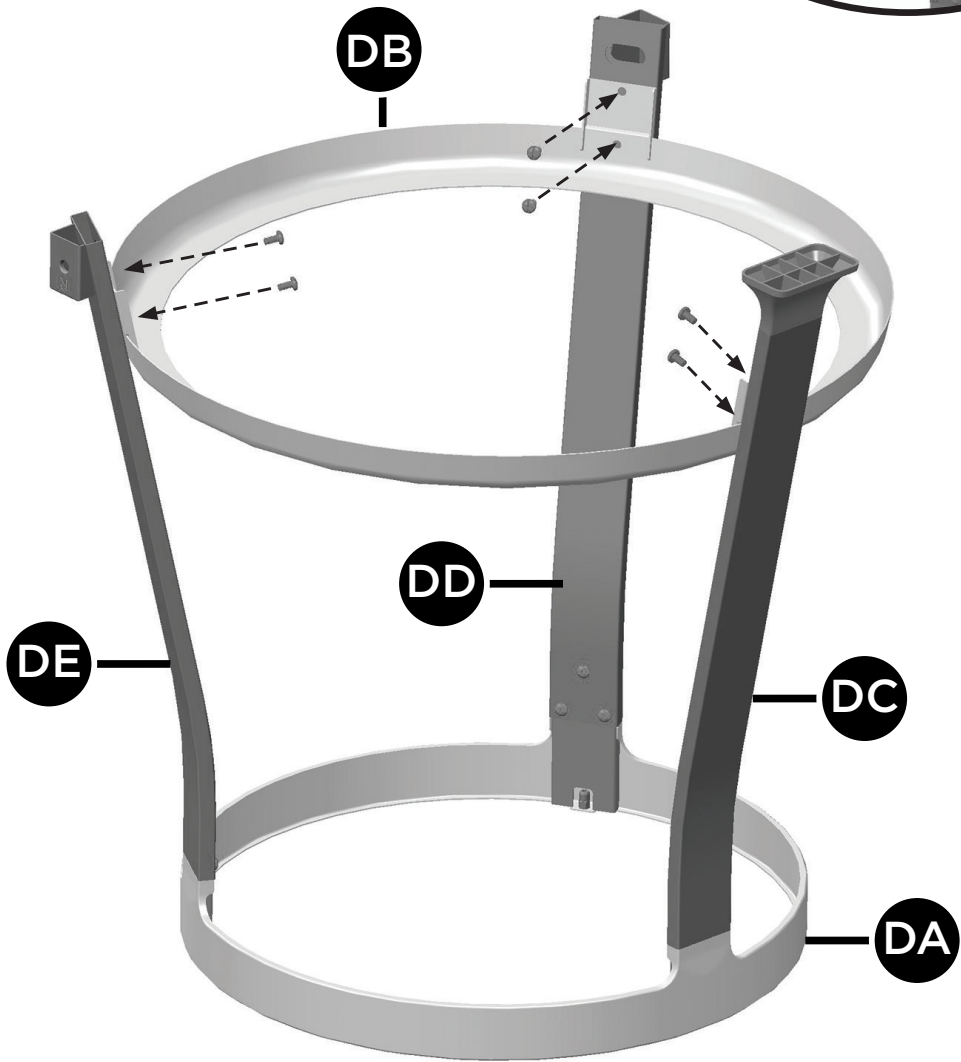
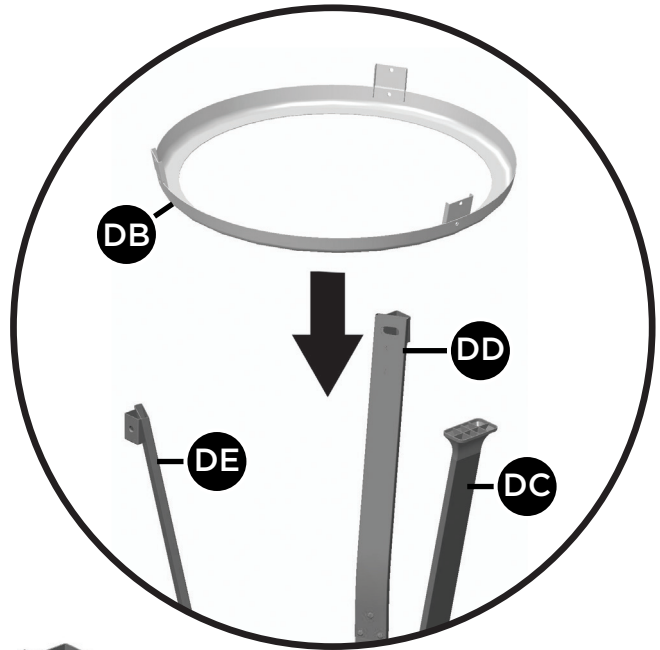
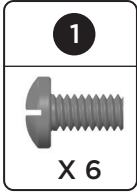

ASSEMBLY INSTRUCTIONS

3

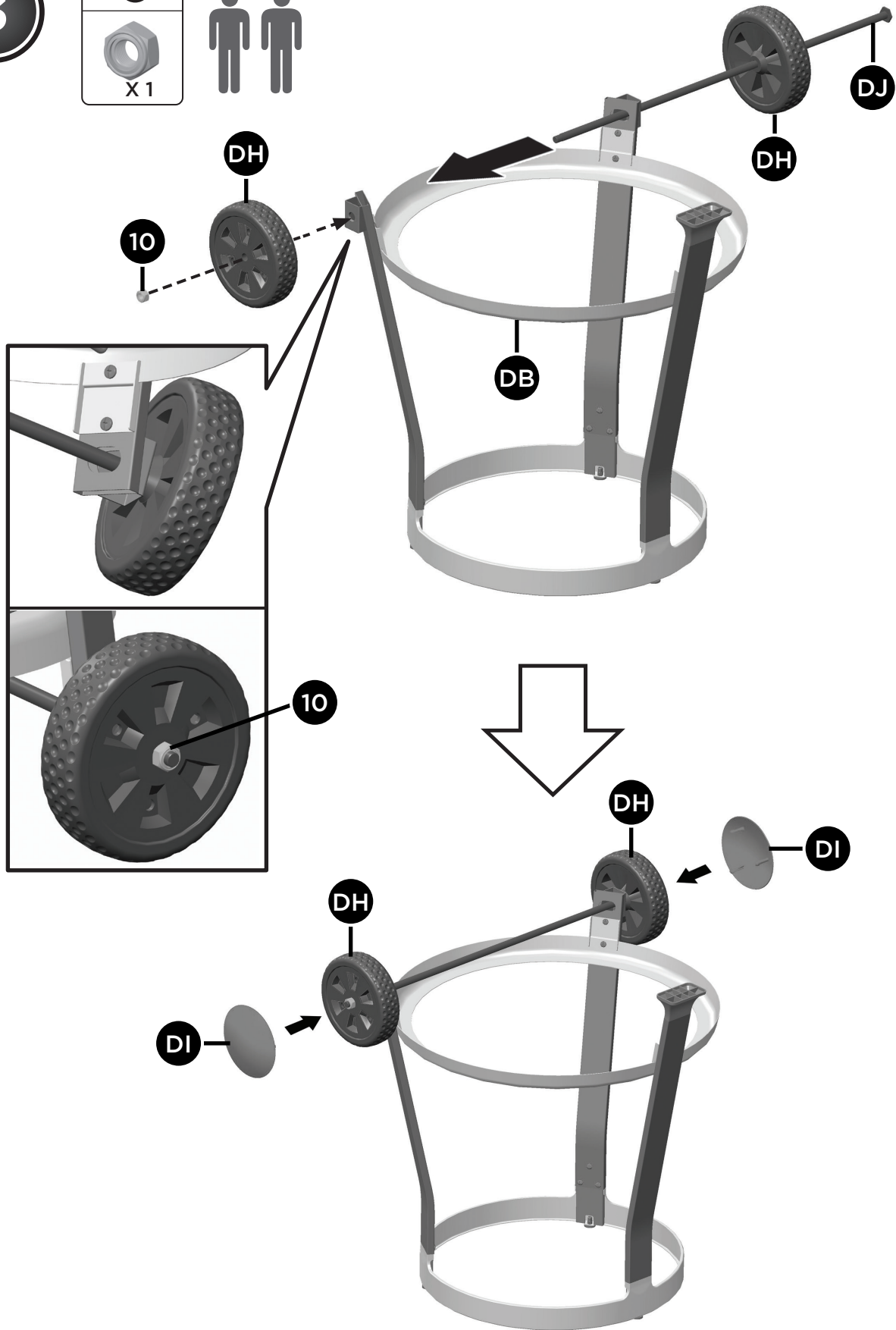
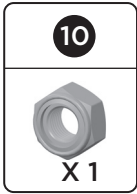

ASSEMBLY INSTRUCTIONS

4

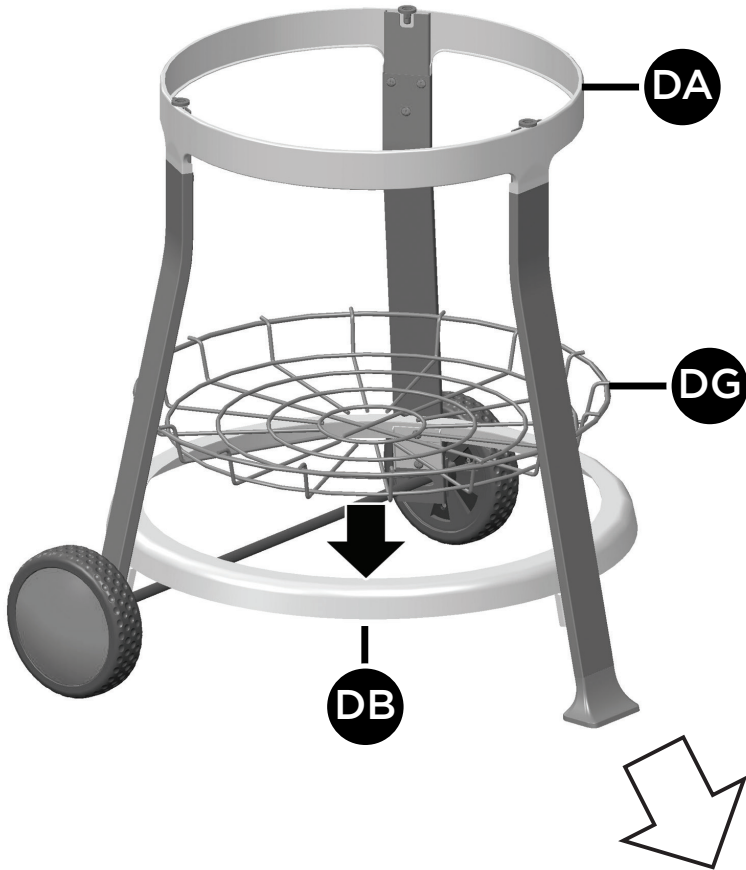

ASSEMBLY INSTRUCTIONS



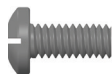

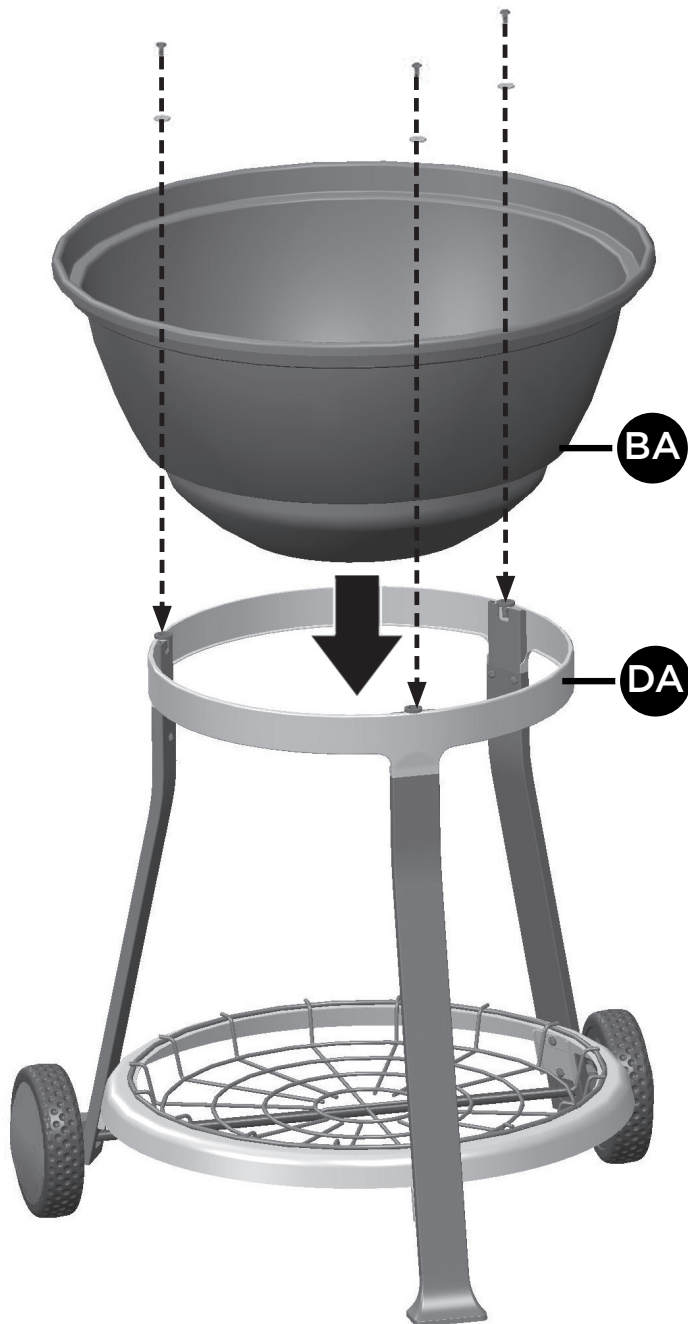
5

4	9
	
X 3	X 3



ASSEMBLY INSTRUCTIONS

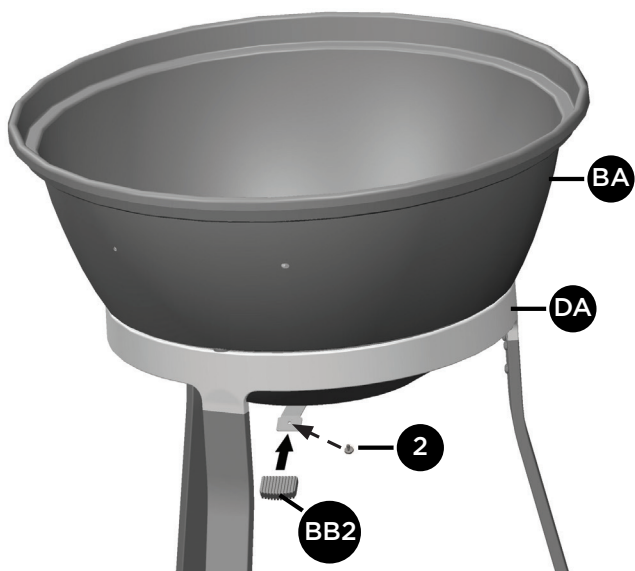
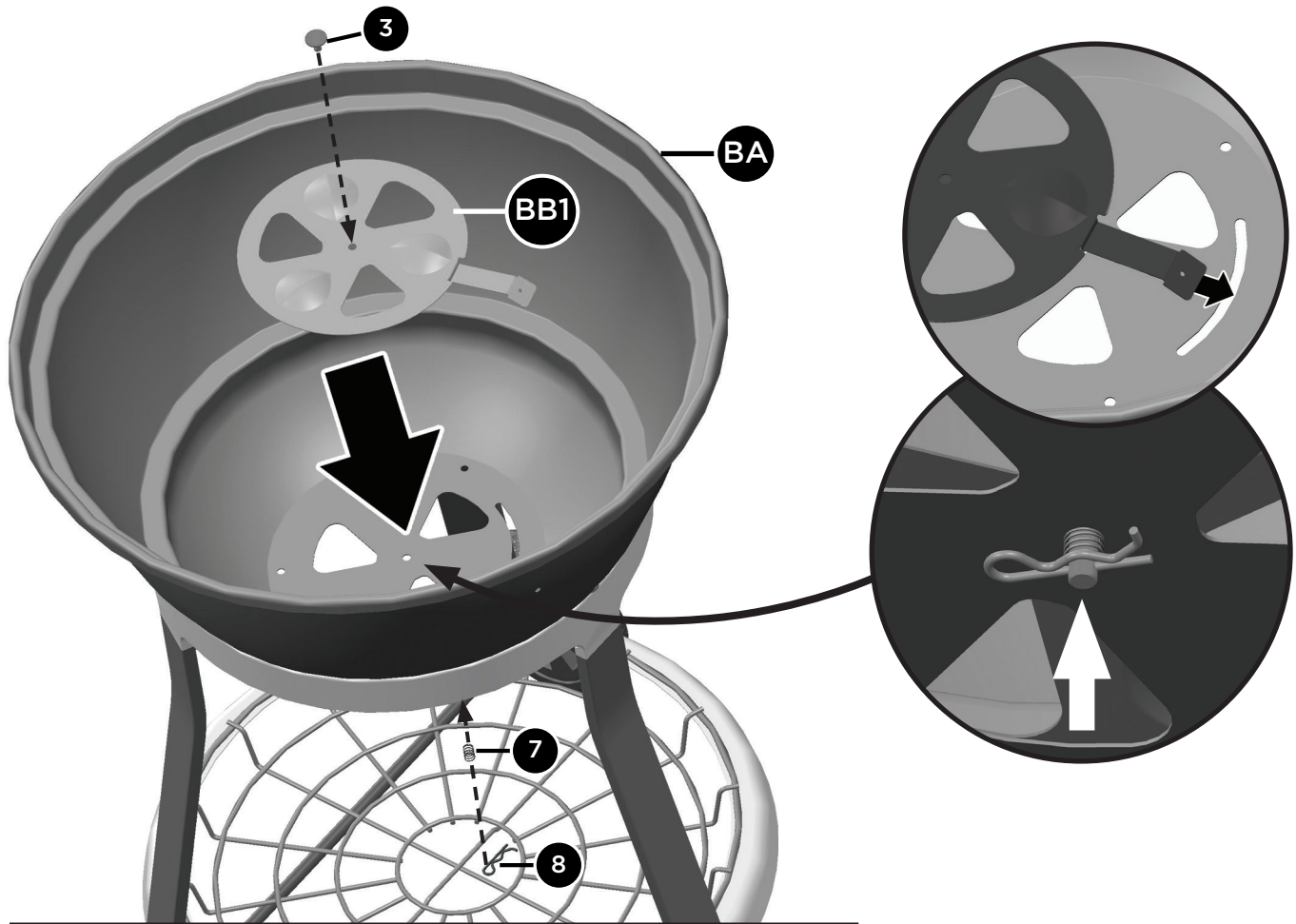

6

2  X1	3  X1	7  X1	8  X1
---	---	---	---



ASSEMBLY INSTRUCTIONS

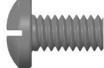

7

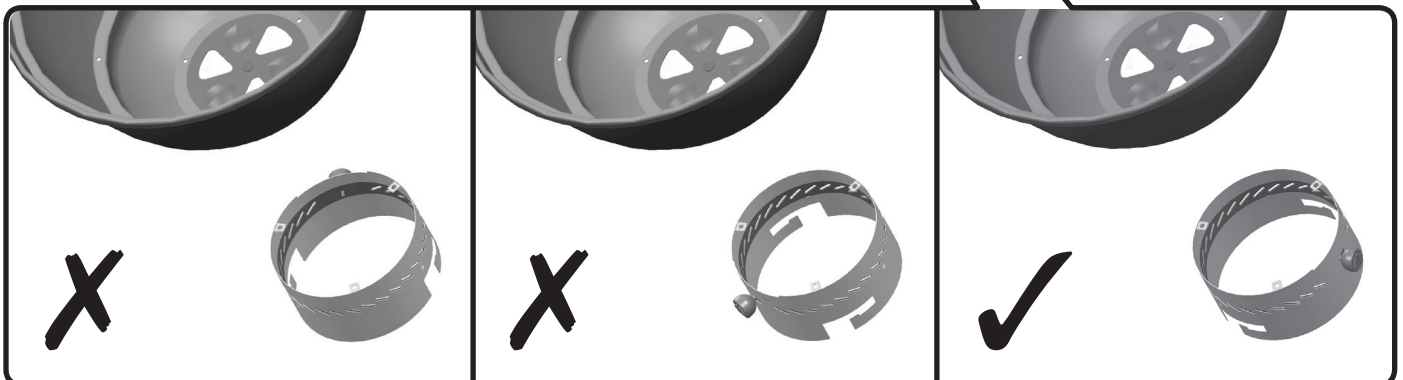
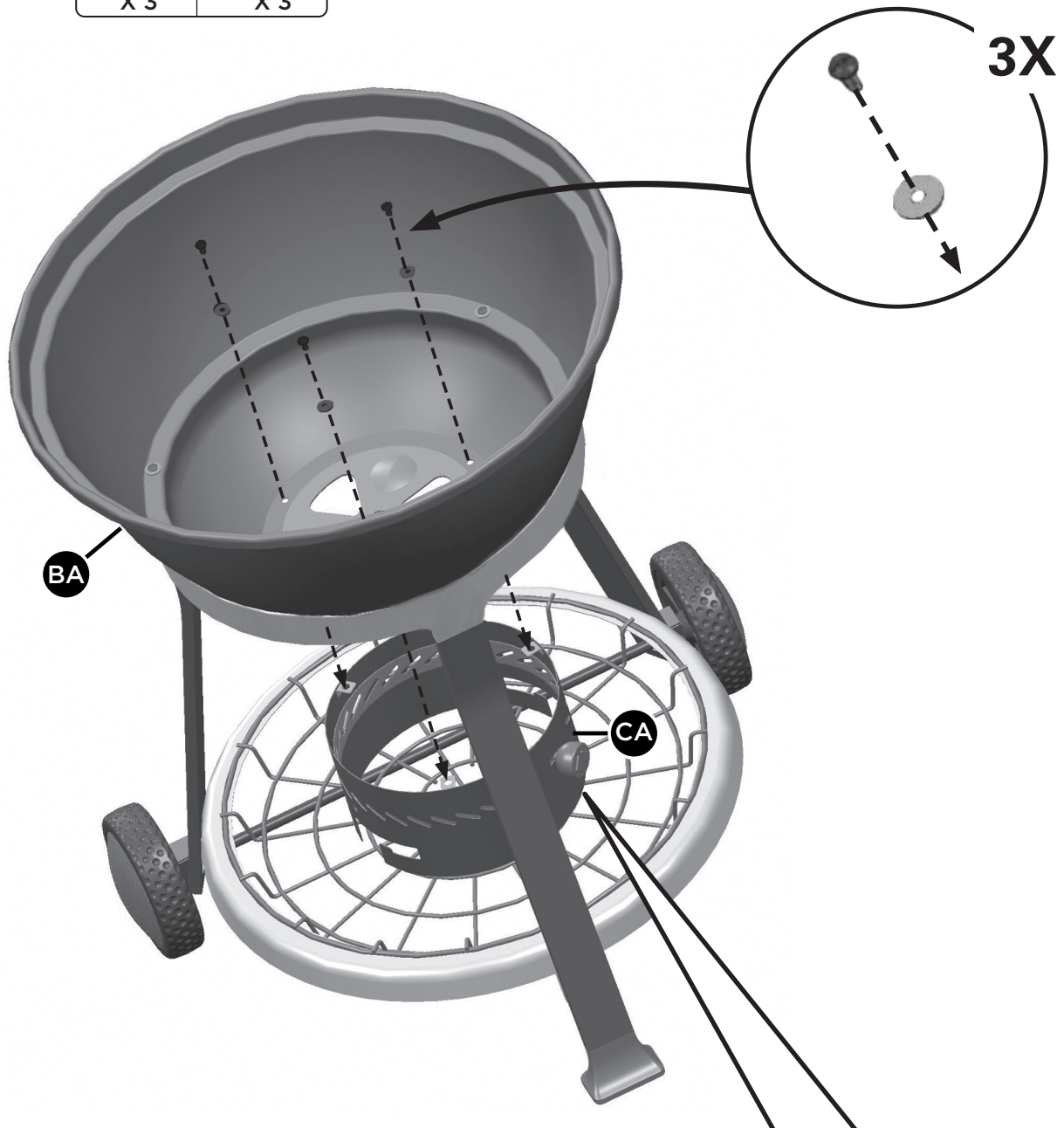
1	4
	
X 3	X 3



ASSEMBLY INSTRUCTIONS

8

4	5	6
		
X 2	X 2	X 2

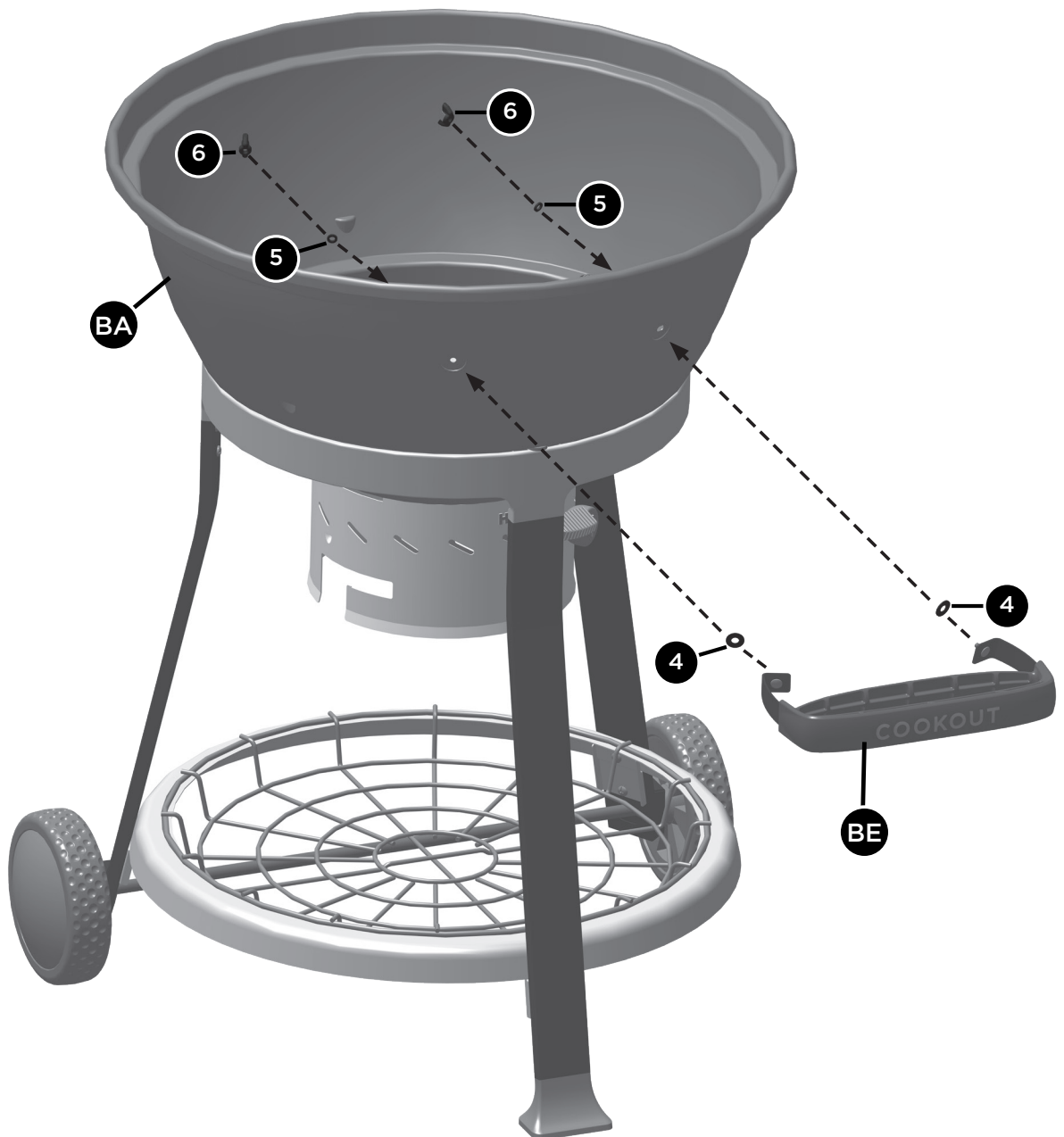

ASSEMBLY INSTRUCTIONS

9

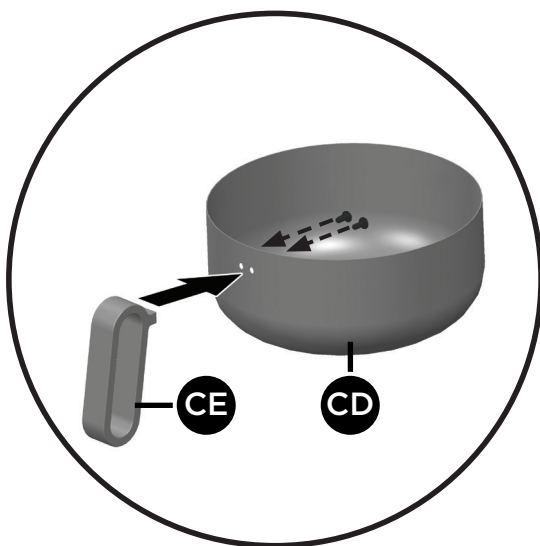
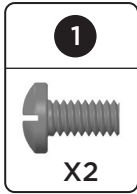



ASSEMBLY INSTRUCTIONS

10



ASSEMBLY INSTRUCTIONS

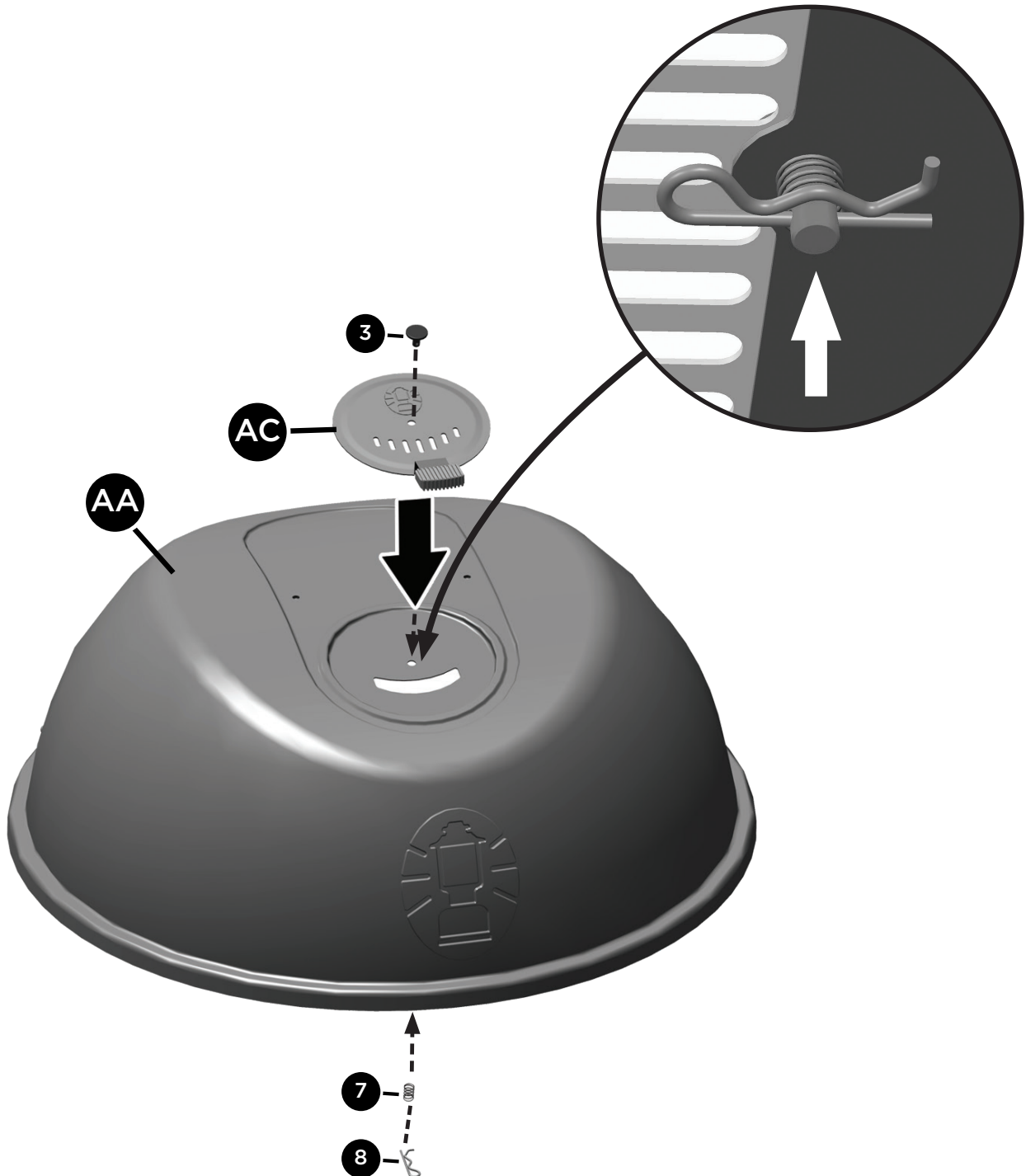

11

3  X 1	7  X 1	8  X 1
--	--	--



ASSEMBLY INSTRUCTIONS

12

5  X 2	6  X 2
--	--

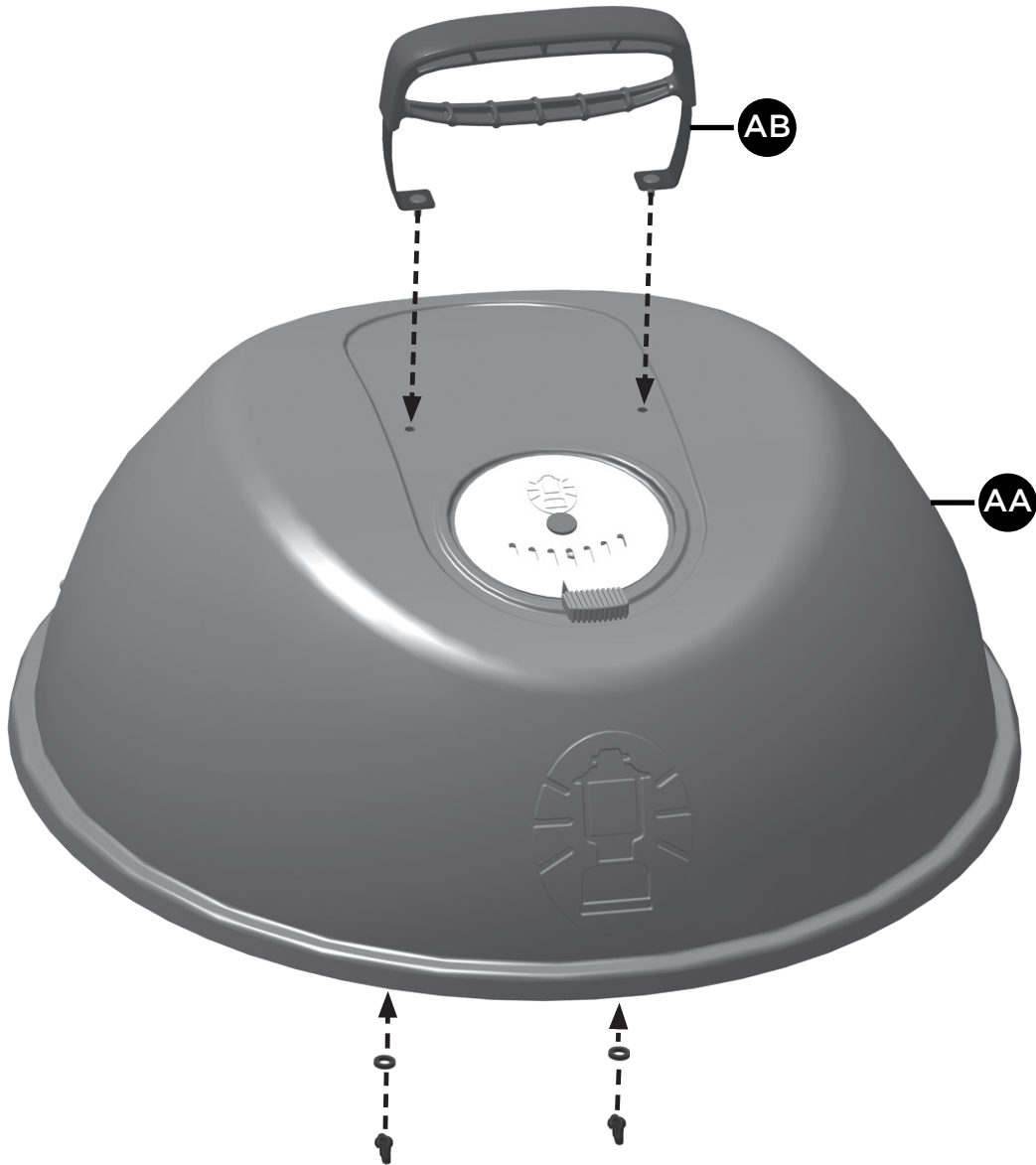

ASSEMBLY INSTRUCTIONS

13



ADDITIONAL WARNINGS

⚠ WARNING HOT SURFACES:

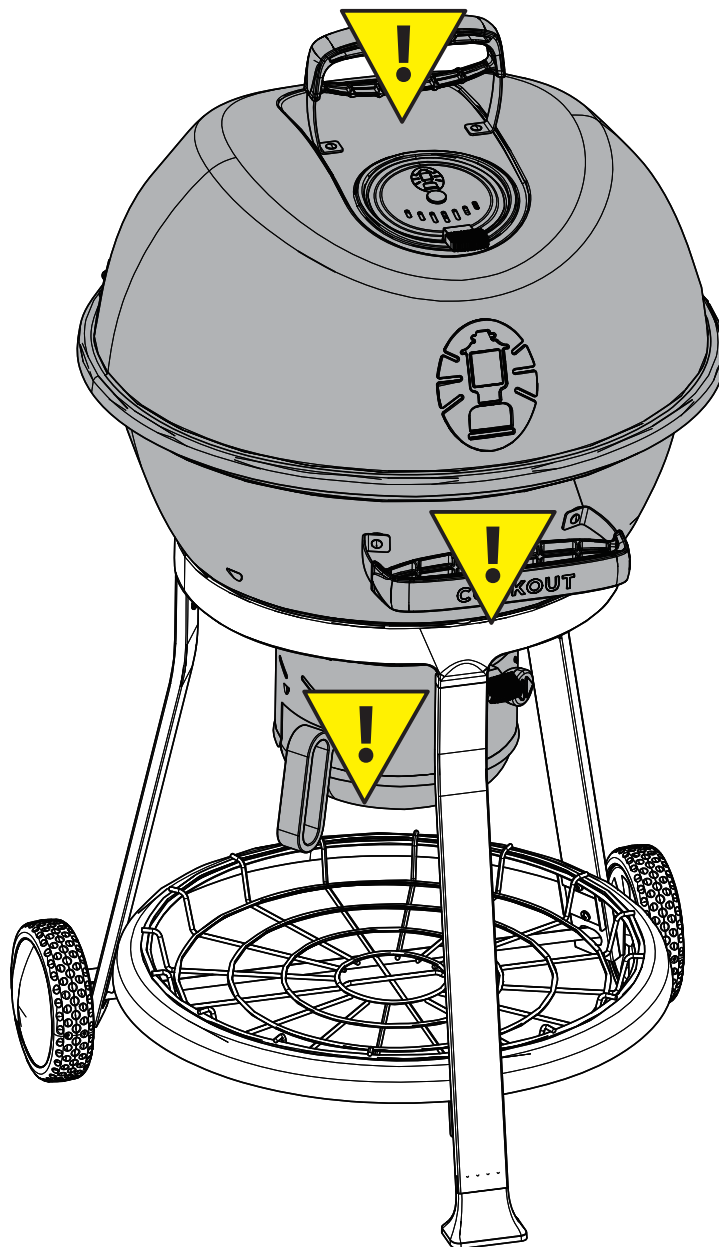

- ⚠ - Avoid Burns**
- Do not touch when charcoal kettle is in use.**
- Extremely hot surfaces.**

WARRANTY AND SERVICE

BEFORE YOU CALL FOR SERVICE have the following information available:

1. **Serial number:** The serial number can be found on the side of the carton, the cover page of the user manuals, and on the rating label located on the cart leg.
2. **Model number:** The model number is located on the front cover of the user manual, the bottom right corner of the rating label and also on your cash register receipt.
3. **Proof of purchase** by the original owner.

**Call the Coleman® Customer Care Hotline 1-800-249-2506
HOURS: 9AM- 7PM EST Mon-Fri, Closed Saturday and Sunday**

IF YOUR PRODUCT IS DAMAGED:

1. Call the Coleman® Customer Care Hotline 1-800-249-2506
2. **Do not return to the store for replacement of damaged or defective parts.** Coleman® Customer Care will ensure that all in-stock replacement parts arrive at your home within 3-10 business days.
3. **Concealed Damage:** If damage is unnoticed until merchandise is unpacked, resolve issue by contacting Coleman® Customer Care immediately. Missing or damaged parts should be claimed within 30 days of purchase.

LIMITED Warranty:

BackHome Products, hereby warrants to the ORIGINAL PURCHASER of this Coleman® COOKOUT™ Charcoal Kettle that it will be free of defects in workmanship, from the date of purchase, for the period of the warranty, as outlined below.

Please see Limitations and Exclusions section on the following page.

Limited 2 Year:

Fire bowl
Lid

Limited 1 Year:

All remaining parts



CAUTION

Some parts may contain sharp edges – especially as noted in the manual! Wear protective gloves if necessary. **For residential use ONLY. Do not use for commercial cooking.**

LIMITATION AND EXCLUSIONS

Backhome Products has the following limitations to its warranty:

1. This limited warranty is non-transferable and becomes void if used for commercial or rental purposes.
2. This warranty applies only when the charcoal kettle is used in the United States.
3. Warranty is in lieu of all warranties, expressed or implied, and all other obligations or liabilities related to the sale or use of its grill products.
4. Backhome Products shall not be liable for incidental, consequential, special or contingent damages resulting from its breach of this written warranty or any implied warranty.
5. Backhome Products will repair or replace parts, at its option, proven defective under normal use and service and which on examination during the applicable warranty period (see exclusions to warranty coverage below).
6. Shipping and handling charges are the responsibility of the original consumer-purchaser for all in/out of warranty part orders.
7. This limited warranty will not reimburse you for the cost of any inconvenience, food, personal injury or property damage.
8. Backhome Products does not authorize any person or company to assume for it any other obligation or liability in connection with the sale, installation, use, removal, return, or replacement of its equipment; and no such representations are binding on Backhome Products.



Backhome Products excludes from its warranty the following:

- a. Accidental damage, abuse, tampering or misuse, misapplication, vandalism, careless handling;
- b. This warranty excludes surface rust or rust perforation, normal wear and tear, chipping and scratching on paint or porcelain enamel surfaces, discoloration caused by heat and smoke, chemical exposure in the atmosphere, and other damages which result with normal use and are otherwise uncontrollable by the manufacturer.
- c. Damages caused by improper assembly installation, or alteration.
- d. Damages caused by failure to follow proper usage, safety and maintenance instructions presented throughout this manual, that result in a fire, personal injury, or property damage;
- e. Improper lighting or use of fuel or fuel lighting accelerants not recommended within this manual, and strictly prohibited for use with this Cookout™ Charcoal Kettle.
- f. Part failure due to lack of cleaning and maintenance, use of improper cleaning products, such as abrasive and chemical cleaners, porcelain oven cleaner and other chemical cleaners which can cause damage to surfaces;

There are no other express warranties except as set forth herein and any applicable implied warranties of merchantability and fitness are limited in duration to the period of coverage of this express written limited warranty.



Licensed by BackHome Products LLC.

©2024 The Coleman Company, Inc.
Coleman®,  and  are registered trademarks of
The Coleman Company, Inc. used under license.