

INSTALLATION INSTRUCTIONS

BMW 3 E46 - ZKW bi-xenon headlight

RFL

Parts needed

2x Aharon Mini D2S projectors
2x Aharon H7 high beam splitter cables
2x E46-r shrouds
2x Bi-xenon stickers (optional)
1x Drill template
Glue (not supplied)

Tools needed

Drill bit 3,5 mm
Torx 20 screwdriver / bit
Philips-head screwdriver (PH2)
Hex / Allen 6 bit
PLiers
Coffee and a bit of patience

Instructions

STEP 1 Remove the original projector

After removing the headlights from the car, unclip the rubber lip, front headlight lens and insert. Remove the D2S bulb and disconnect the Bi-xenon solenoid wiring. Also disconnect the H7 high beam wiring.



Turn the height adjustment to the lowest position.

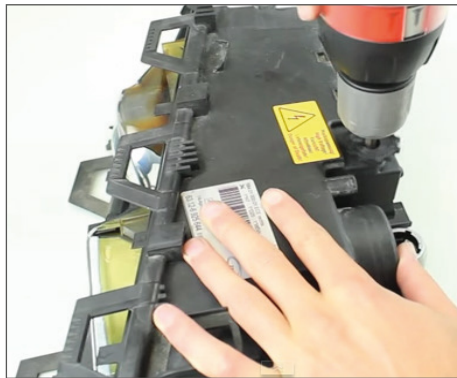

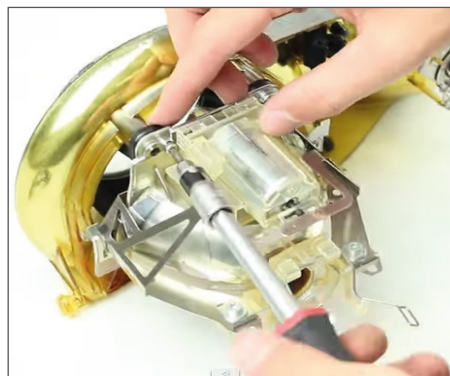

Unclip the top hinge. Remove the frame from the housing. Rotate it further downwards and slide it over the ball hinge. Remove the projector bowl by removing all the Torx screws. Unclip and remove the shroud and lens frame. Also remove the rubber rings inside the mounting holes don't throw them away!

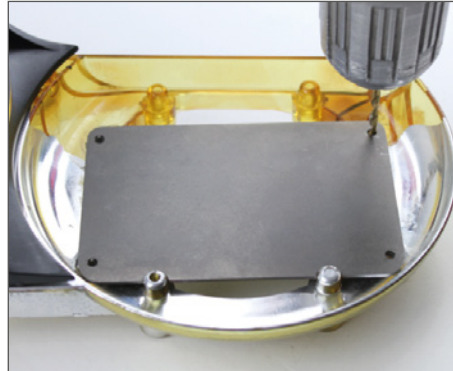
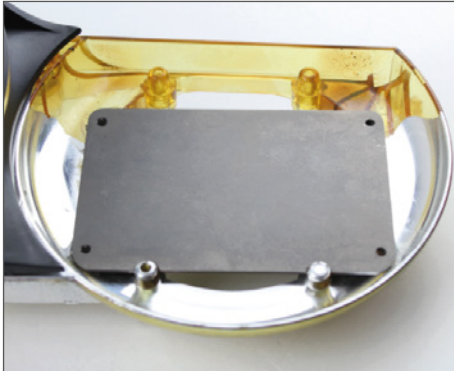

STEP 2 Mounting the new projector

Place the drill template/bracket on the plastic frame. The template must be centered, and placed directly against the two silver pins on the bottom side. Drill 3,5 mm holes.



 Please note: do not align the template bracket to the flat top side of the frame, this section is not level to the ground. The silver pins are level.

The bottom of the projector needs to be trimmed to make it fit. Trim it down for about 5mm. Please see the highlighted part in the picture below:

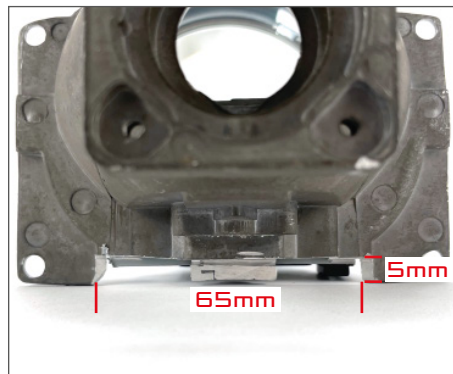
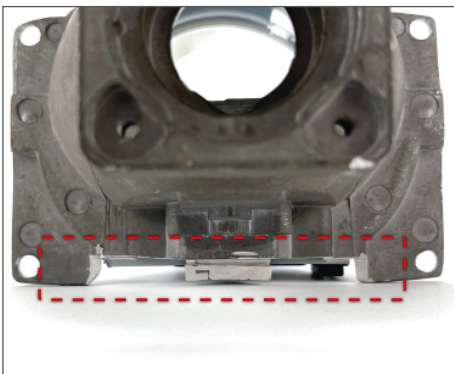

Mount the projector using 2 rubber rings from the original projector, 2 black plastic spacers and the 4 PH screws. The rubber rings and spacers need to be placed between the projector and the plastic frame. Make sure the solenoid (magnetic coil) is facing the bottom of the plastic frame. The 2 supplied black plastic spacers are used on the top. The 2 rubber rings are used on the bottom.

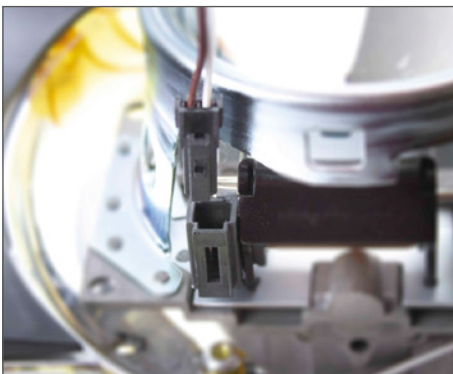

Plug-in the solenoid cables into the female connector at the front of the projector. Make sure the solenoid cable is guided to the back of the reflector.

Place the frame back in the housing, following the opposite steps of the removal procedure.

Remove the clips from the inside of the shroud. Mount the shroud to the lens holder of the projector using glue or epoxy. Before mounting, make sure the solenoid wires are plugged in. *Please note: it's better not to touch the shroud. Use gloves or the packaging foam to prevent fingerprints and scratches.*

[Optionally] There is also - a specially designed - Bi-Xenon sticker supplied. You can mount this sticker by removing the white backing paper. Align the letters around the inner opening of the new E46 shroud.



STEP3^a Mounting the D2S bulb - ECE projector

Mount the bulb holder parts onto the D2S xenon bulb, like shown in the pictures. Insert the bulb into the shaft of the projector (with the bulb tube facing down) and twist the bulb clockwise until the little pins on the bulb align horizontally.



STEP3^b Mounting the D2S bulb - DOT projector

Mount the bulb holder onto the back of the projector using the 4 supplied PH screws. Make sure the pivot point is facing the bottom of the projector. Insert the bulb into the shaft of the projector (with the bulb tube facing down).

Tighten the clip and check if the lamp is securely in place.

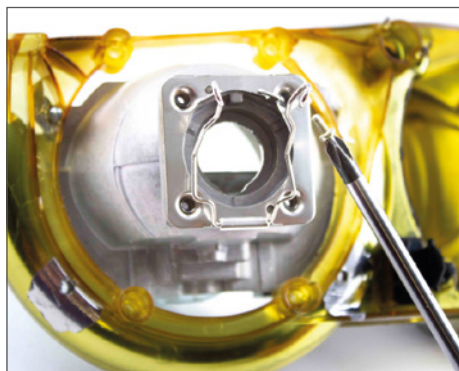

STEP 4 Connect the solenoid cable

Connect the solenoid wiring for the high-beam function. The solenoid is activated with 12 Volts on the brown and white wires. How you should connect it depends on your location.

1. Europe/ rest of the world: A H7 splitter is supplied.

Simply connect the H7 splitter between the headlights H7 high beam plug and the H7 halogen bulb. The other small connectors plug on to the solenoid wire.

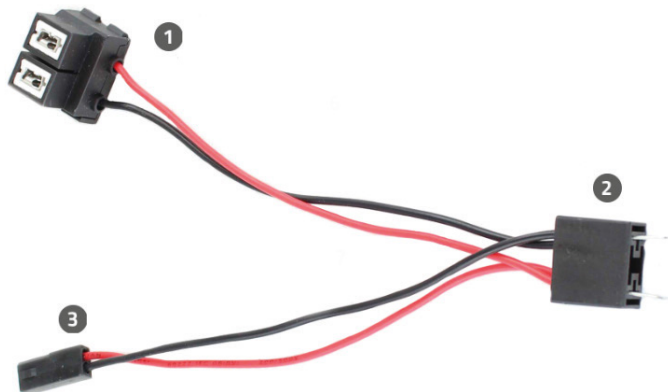

1. connect to H7 halogen high beam bulb

2. connect to H7 high beam feed from headlight

3. connect to solenoid cable of the projector.

2. US and Canada: Connect the brown and white solenoid wires in your headlight (which were also connected to the ZKW projector) to the red and black wires of the new projector. Use the supplied tap splice connectors, or solder the wires. The solenoid has no polarity, so there's no specific color coding.



STEP 5 Done :)

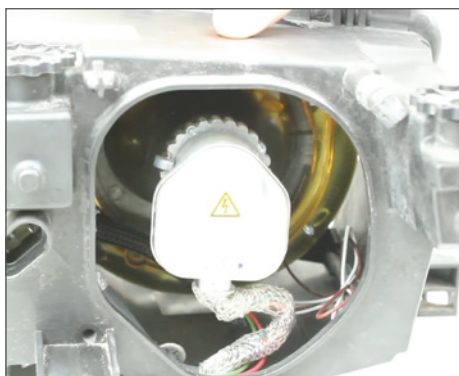

More info?



For more info about retrofitting and wire connections please scan the QR-code or visit <https://retrofitlab.com/pages/installation-instructions>