

AeroVent® 3X Product Manual



1700 Jasper St. Unit F, Aurora, CO 80011 T 800.624.6706 F 303.364.7796 • Newstripe.com

AeroVent® 3X Manual / 4721.0117rev1

January 2, 2018

Attn:

Purchaser's of the Newstripe,

AeroVent 1X, 3X or Standard

Aerosol Can Recycling units Respirator Required Decal

Dear Customer:

We thank you for your purchase of the AeroVent aerosol can recycling unit and apologize for the inconvenience that may be caused concerning the RESPIRATOR REQUIRED decal on the unit.

Obviously, many companies have comprehensive safety programs in place that would supersede this decal and it would not be necessary. Unfortunately, many of our customers do not. So, in the interest of safety, we have chosen to err on the side of caution with regards to those that may not have programs in place.

For example, the AeroVent X as designed is intended to puncture mostly empty cans, (those exhausted through normal discharge). However, some users have chosen to puncture and drain cans that are close to full. This quickly exhausts the effectiveness of the carbon filter requiring more frequent filter changes that may or may not be done. Others have located the unit on a shop floor that is merely 'open atmosphere' with no fans or HIVAC for additional air movement. These are two examples of when a respirator should absolutely be worn.

On the other hand, a respirator would not be mandatory if the unit is operated outdoors or in a well ventilated area and the operator is 'upwind' of the exhaust port during puncturing or when opening the lid to insert or remove cans.

We appreciate your understanding of our position and please let us know if we may assist in satisfying your requirements.

Sincerely,

Ray Krebs

General Manager

AeroVent® 3X

TABLE OF CONTENTS

| | |
|-------------------------------|--------|
| Precautionary Warning | Page 1 |
| Assembly | Page 2 |
| Assembly Drawing..... | Page 3 |
| Parts List..... | Page 3 |
| Operation..... | Page 4 |
| Maintenance | Page 5 |
| Cobalt Point Replacement..... | Page 5 |
| Safe2Vent™ Replacement..... | Page 6 |
| Warranty..... | Page 7 |

Thank you and congratulations on your purchase of the AeroVent® 3X aerosol can disposal system.

The AeroVent® 3X has been designed to puncture and drain aerosol cans that have been used and are mostly empty. It is not intended to continuously process full cans.

Caution: Full cans must be punctured one at a time and in the center position only!

Please read over the instructions and make sure you understand operating procedures before using the unit.

AeroVent® 3X

ALWAYS wear appropriate personal protective equipment when operating the unit!



- Always consult your facility safety manager for specified safety protocols prior to operating this equipment.
- Please read and understand all operation instructions as detailed in this manual. Failure to follow specified instructions may result in equipment damage or serious injury to personnel, including death.
- Always refer to the Product SDS for specific chemical handling and safety instructions prior to deflating aerosol cans.
- Liquids collected into drums may contain highly flammable liquid and vapor. Keep away from heat, sparks and flame – No smoking near the unit or drum.
- Take precautionary measures against static discharge. Ensure the grounding cable is attached to a suitable grounding source such as a metal water pipe or grounding rod.
- Keep the container closed when not in use.
- Store in a cool, well-ventilated area away from heat and ignition sources.
- Use only in a well-ventilated area.
- Avoid contact with eyes, skin, and clothing.
- Wear appropriate personal protective equipment; avoid direct contact with aerosol can contents.

CAUTION: Use of filters not specifically designed for the AeroVent® Aerosol Can Disposal Systems may result in dangerous back-pressure inside the recovery drum, resulting in equipment damage or serious injury to personnel, including death.

- Always refer to the Product Safety Data Sheet to check chemical compatibility when multiple aerosols are to be co-mingled in the same collection drum.
- Caustics, pesticides, insecticides, and white metals should not be collected into a drum with other liquid residuals and should be segregated into properly-labeled designated containers. Contact your waste handler for more information.



1700 Jasper St. Unit F, Aurora, CO 80011 T 800.624.6706 F 303.364.7796 • Newstripe.com

AeroVent® 3X Manual / 4721.0117rev1

AeroVent® 3X

ALWAYS wear appropriate personal protective equipment when operating the unit!

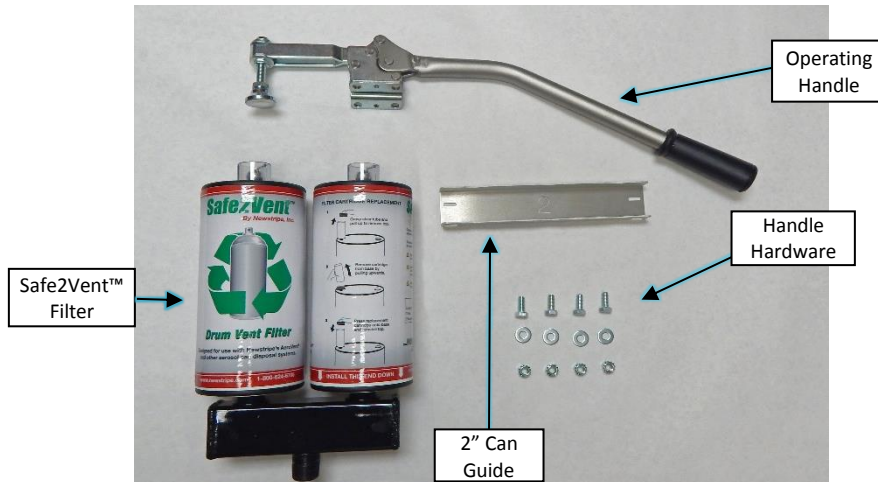

Included Parts:

- AeroVent®3X unit with ground cable
- Safe2Vent™ Dual Filter with Manifold
- Operating Handle
- Operating Handle Hardware: Bolts (4), Washers (4), Nuts (4)
- 2" Can Guide

Tools needed for assembly:

(Not included)
(2) 1/2" wrenches.

ASSEMBLY

1. Remove the 2" bung cap from an empty 30 or 55 gallon recovery drum. Insert the threaded nipple of the AeroVent® 3X into the opening and turn the unit until it is hand tight. Center the unit over the drum.
2. Adjust the rear support feet clockwise until they are snug to the top of the drum. Then, adjust the front support foot until it is tight to the rim of the drum (the "chime").
3. Place the operating handle on the mounting plate so that the holes are aligned. Insert one bolt (with washer) through each hole. Loosely install one locking nut onto each bolt, but do not tighten yet. (Figure 1)
4. Lower the operating handle so that the swivel foot is centered side-to-side on the lid striker plate. Now tighten all nuts and bolts of the operating handle assembly to the mounting plate. (Figure 2)
5. **Note: Lift the top and remove the plastic wrapping before using the Safe2Vent™ Filter.** Remove the 3/4" bung cap from the top of the recovery drum and thread the Safe2Vent™ Dual Filter with Manifold into place. Hand-tighten only!
6. **Attach the clamp end of the grounding cable to a suitable grounding source, such as a metal water pipe or grounding rod.**

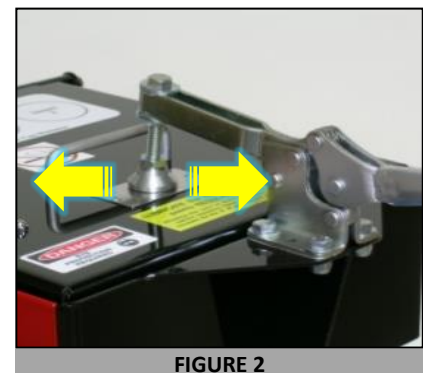
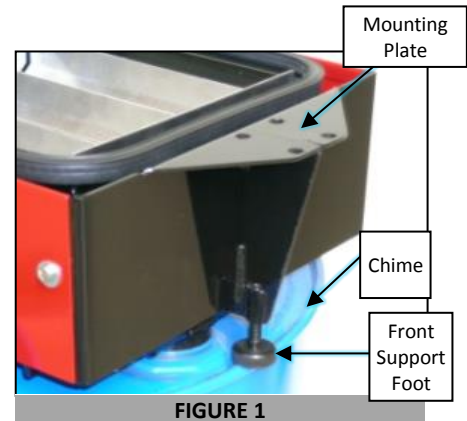

1700 Jasper St. Unit F, Aurora, CO 80011 T 800.624.6706 F 303.364.7796 • Newstripe.com

AeroVent® 3X Manual / 4721.0117rev1

AeroVent® 3X

ALWAYS wear appropriate personal protective equipment when operating the unit!

ASSEMBLY DRAWING

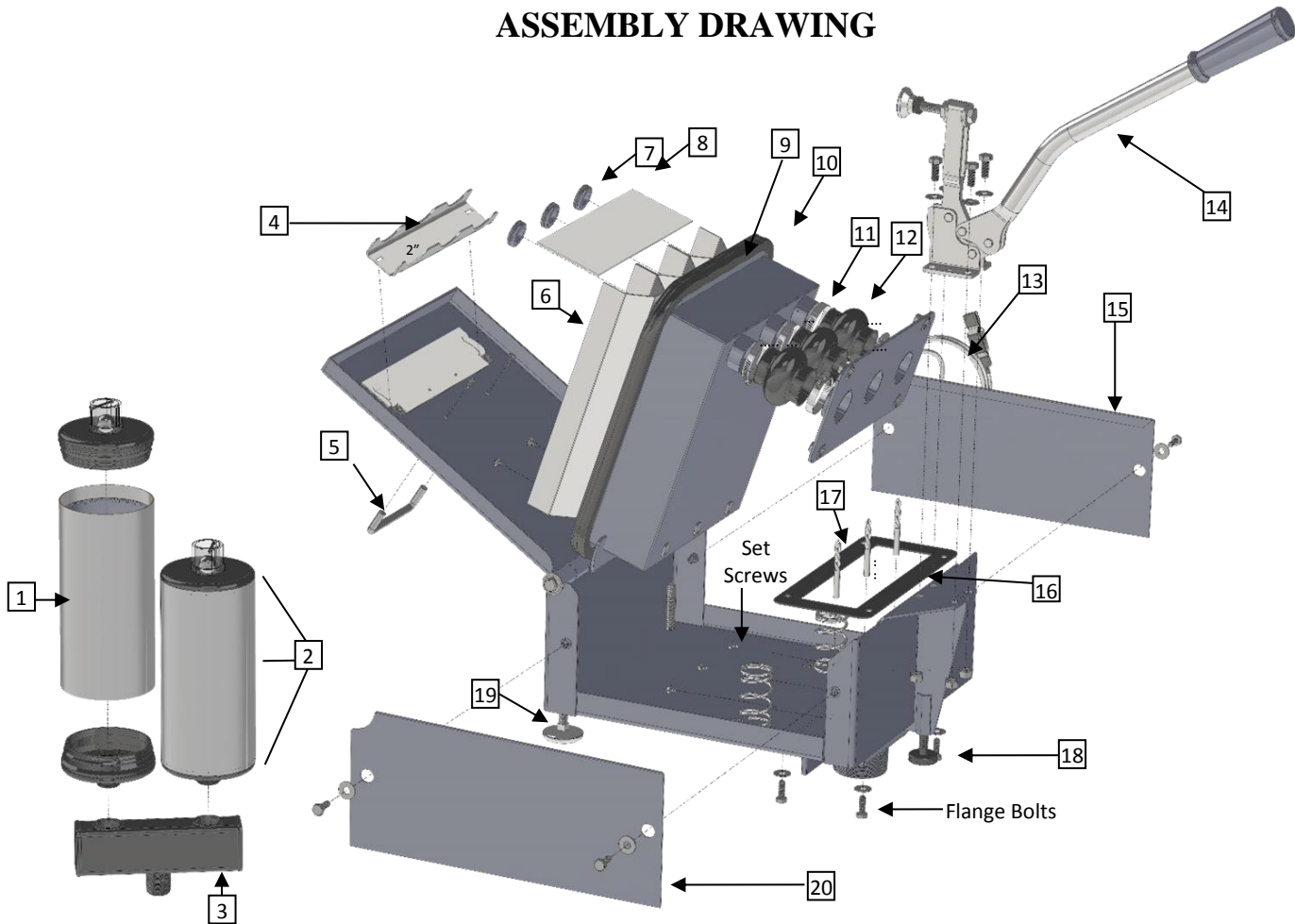

PARTS LIST

| ITEM NUMBER | DESCRIPTION | PART NUMBER |
|-------------|---|----------------------|
| 1. | Safe2Vent™ replacement element (Package of 2) | 10004703 |
| 2. | Safe2Vent™ Dual Filter w/ Manifold | 10004722 |
| 3. | Manifold | 10004709 |
| 4. | Can Guide 2" 2.6" | 10004331 10004332 |
| 5. | Lid Handle | 10004195 |
| 6. | Trough Liner (3 required) | 10004297 |
| 7. | Trough Liner Grommet (3 required) | 10001874 |
| 8. | Flange Gasket | 10004344 |
| 9. | Lid Gasket | 10004343 |
| 10. | Bellows Clamp (6 required) | 10003794 |

| ITEM NUMBER | DESCRIPTION | PART NUMBER |
|-------------|--------------------------------|-------------|
| 11. | Trough | 10004339 |
| 12. | Bellows (3 required) | 10003791 |
| 13. | Grounding Cable w/clamp | 10003914 |
| 14. | Operating Handle w/swivel foot | 10003909 |
| 15. | Right Shroud | 10004287 |
| 16. | Flange Gasket | 10004344 |
| 17. | Cobalt Point (3 required) | 10003377 |
| 18. | Left Shroud | 10004286 |
| 19. | Front Support Foot | 10004306 |
| 20. | Rear Support Foot (2 required) | 10004305 |



1700 Jasper St. Unit F, Aurora, CO 80011 T 800.624.6706 F 303.364.7796 • Newstripe.com

AeroVent® 3X Manual / 4721.0117rev1

AeroVent® 3X

ALWAYS wear appropriate personal protective equipment when operating the unit!

OPERATION

1. Lift the operating handle to release the clamp, and open the AeroVent® 3X lid.
2. Ensure that the front panel is in place in front of the trough liners.
3. Using the guide on the side of the unit, select the corresponding can guide for the size of the can being punctured. Insert the can guide into the retainer clips located on the underside of the AeroVent® 3X lid. Slide the can guide onto the retainer clips until it locks into place. Remove the can guide completely when draining 3” diameter cans.

NOTE: Use of the wrong can guide will result in aerosol cans not puncturing correctly and improper sealing of the lid, which will result in the leakage of can contents and vapors during draining.

4. Insert aerosol cans with **the bottom of the can pointing toward the clamp**, and up against the front of the panel in the trough. (The clamp will engage the lid and push the lid down).

NOTE: When processing less than three cans, insert single cans into the center trough liner and dual cans into the outside trough liners. While processing multiple cans simultaneously, only puncture aerosol cans of the same diameter or cans may not puncture correctly and improper sealing of the lid can occur.

5. Close the lid. Pushing down on the operating handle will clamp the lid down and engage the puncture mechanism.
6. The aerosol cans have now been punctured and are draining. Wait 15-30 seconds and confirm the Viz-a-Ball™ indicators have stopped moving to ensure the cans are completely drained. You may now lift the handle and open the lid to remove the cans.

Note: If aerosol cans are mostly full, leave the handle in the locked position for 45-60 seconds to allow the cans to drain completely.

PRECAUTIONARY WARNING!



- Do not use the AeroVent® 3X for draining expanding foam sealant aerosol products or spray adhesive products.
- Always use the correct can guide for the diameter of the cans that you are draining.
- The clamp must remain locked until the cans are fully drained.
- To ensure that the cans are drained, wait 15-30 seconds and confirm the Viz-a-Ball™ indicators on the drum filter have stopped, before un-locking the clamp and opening the lid.
- If a can is full when punctured, wait at least one minute before opening the unit. Full cans take longer to empty and may discharge fumes or liquids if the unit is opened too soon.
- We recommend changing the carbon filter every 90 days or 600 cans. If cans contain larger amounts of remaining liquids, change the filters more often. Also, we do not recommend allowing the drum to become more than 2/3 full. An air space is needed in the drum to allow for draining and venting of fumes. Do not use single Safe2Vent™ Filters. This unit is designed to be used with the Safe2Vent™ Dual Filters only.



1700 Jasper St. Unit F, Aurora, CO 80011 T 800.624.6706 F 303.364.7796 • Newstripe.com

AeroVent® 3X Manual / 4721.0117rev1

AeroVent® 3X

ALWAYS wear appropriate personal protective equipment when operating the unit!

MAINTENANCE

| ITEM | CHECK | ACTION |
|--------------------------------------|-----------------|---|
| Lid Gasket 10004249 | Before each use | Replace As Necessary |
| Safe2Vent™ Element (2 pack) 10004703 | Monthly | Replace Every 90 days or 600 cans, more often for full cans |
| Cobalt Point (3) 10003377 | Before each use | Replace As Necessary |
| Bellows (3) 10003791 | Every 180 days | Replace As Necessary |
| Trough Grommet (3) 10001874 | Before each use | Replace As Necessary |
| Operating Handle. 10003909 | Before each use | Lubricate regularly with light oil. (3-in-1, WD-40 etc.) |

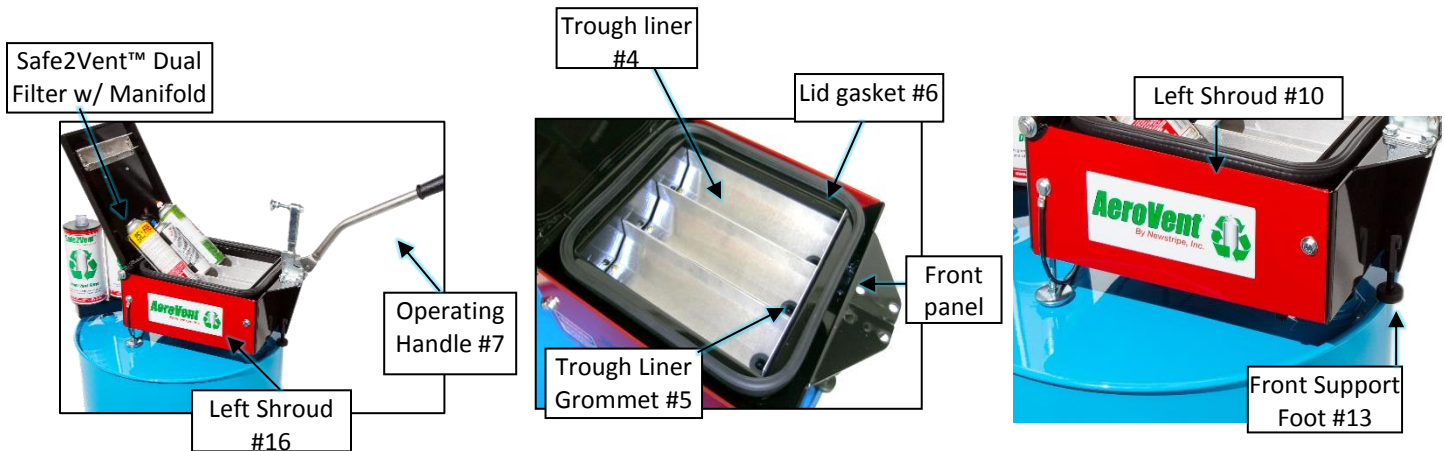

COBALT POINT REPLACEMENT

(See Assembly Drawing Page 3)

HELPFUL HINT: Leave the unit mounted on the drum to replace the cobalt points.

1. Open the lid and remove the left and right shrouds including the grounding cable.
2. Remove the four bolts that secure the bellows flange to the base from underneath the unit. There is no need to loosen any of the bellows clamps, unless the bellows are damaged and need to be replaced.
3. Rotate the trough assembly upward and allow it to rest against the lid.
NOTE: The bellows flange may have to be gently pried off of the flange gasket to rotate the assembly up.
4. Loosen the (3) set-screws with a 5/16" wrench and replace the points. Tighten the bolts against the new points.
5. Re-assemble the unit in the reverse order of the steps above.

NOTE: Do not forget to install the grounding cable.



1700 Jasper St. Unit F, Aurora, CO 80011 T 800.624.6706 F 303.364.7796 • Newstripe.com

AeroVent® 3X Manual / 4721.0117rev1

AeroVent® 3X

ALWAYS wear appropriate personal protective equipment when operating the unit!

SAFE2VENT™ REPLACEMENT

1. Remove the filter cap with Viz-a-Ball™ from the filter element.
2. Lift off the filter element from the filter base.
3. Press the new element onto the filter base.
4. Replace the filter cap with Viz-a-Ball™ by pressing it into the top of the element.
5. Repeat the steps above for each filter in the Dual Filter assembly.
6. Dispose of the used filter elements appropriately.



1700 Jasper St. Unit F, Aurora, CO 80011 T 800.624.6706 F 303.364.7796 • Newstripe.com

AeroVent® 3X Manual / 4721.0117rev1

AeroVent® 3X

ALWAYS wear appropriate personal protective equipment when operating the unit!

THE NEWSTRIPE WARRANTY – 18 MONTH

NEWSTRIPE, INC., WARRANTS TO THE ORIGINAL PURCHASER, FOR 18 (EIGHTEEN) MONTHS AFTER DATE OF PURCHASE, THAT THE EQUIPMENT* HEREBY SOLD SHALL BE FREE OF DEFECTS IN MATERIALS AND WORKMANSHIP. THIS WARRANTY DOES NOT EXTEND TO ANY DAMAGE OR MALFUNCTION RESULTING FROM MISUSE, NEGLIGENCE, ACCIDENT, IMPROPER OPERATION, OR NORMAL WEAR AND TEAR.

Damage incurred in shipment from Newstripe, Inc. to the customer is the total responsibility of the carrier. The CUSTOMER MUST NOTE DAMAGES on the Bill of Lading from the trucking company or railroad, and Newstripe, Inc. will furnish to the customer the cost of parts and labor. The customer can then bill the common carrier for the damages by placing his or her signature on the documents.

The Newstripe, Inc. obligation under this warranty and any implied warranties is limited to replacement or repair of defective parts of its manufacture without charge for 18 (Eighteen) months from date of purchase. For service under this warranty, buyer shall ship the defective part or parts of the equipment, transportation prepaid, to Newstripe, Inc. together with a written description of any claimed defect and proof of purchase date of the materials being returned. **Prior to returning any part or machine, the CUSTOMER must obtain a Return Materials Authorization number. Call 1-800-624-6706. To review the complete guidelines for warranty and returns, please visit www.newstripe.com.**

The responsibilities described above are the only responsibilities of Newstripe, Inc. under this written warranty or any implied warranty, and may be exercised only within 18 (Eighteen) months from the date of purchase. In no event shall Newstripe, Inc. be liable for incidental or consequential damages and no person has any authority to bind it to any representation or warranty, responsibility for work done, materials furnished or repairs made by others without Newstripe's specific written authorization.

THIS WARRANTY SHALL BE IN LIEU OF ANY AND ALL OTHER WARRANTIES, EXPRESSED OR IMPLIED, INCLUDING ANY WARRANTIES OF MERCHANTABILITY OR FITNESS FOR A PARTICULAR PURPOSE, AND THERE IS NO OTHER REPRESENTATION OR WARRANTY OF ANY KIND WITH RESPECT TO THE GOODS SOLD HEREBY EXCEPT AS SET FORTH HEREIN. IT IS EXPRESSLY AGREED THAT THIS WARRANTY SHALL BE LIMITED TO THE ADJUSTMENT, REPAIR OR REPLACEMENT OF PARTS AND THE LABOR AND SERVICES REQUIRED THEREBY. IN NO EVENT, INCLUDING ANY CLAIM FOR NEGLIGENCE, SHALL NEWSTRIPE, INC. BE LIABLE FOR INCIDENTAL OR CONSEQUENTIAL DAMAGES.

Sincerely,
Newstripe, Inc.



1700 Jasper St. Unit F, Aurora, CO 80011 T 800.624.6706 F 303.364.7796 • Newstripe.com

AeroVent® 3X Manual / 4721.0117rev1