

AeroVent® 1X

Product Manual



1700 Jasper St. Unit F, Aurora, CO 80011 T 800.624.6706 F 303.364.7796 • Newstripe.com

AeroVent® 1X Manual // 4700.0117

AeroVent® 1X

January 2, 2018

Attn:

Purchasers of the Newstripe,

AeroVent 1X, 3X or Standard

Aerosol Can Recycling units Respirator Required Decal

Dear Customer:

We thank you for your purchase of the AeroVent aerosol can recycling unit and apologize for the inconvenience that may be caused concerning the RESPIRATOR REQUIRED decal on the unit.

Obviously, many companies have comprehensive safety programs in place that would supersede this decal and it would not be necessary. Unfortunately, many of our customers do not. So, in the interest of safety, we have chosen to err on the side of caution with regards to those that may not have programs in place.

For example, the AeroVent X as designed is intended to puncture mostly empty cans, (those exhausted through normal discharge). However, some users have chosen to puncture and drain cans that are close to full. This quickly exhausts the effectiveness of the carbon filter requiring more frequent filter changes that may or may not be done. Others have located the unit on a shop floor that is merely 'open atmosphere' with no fans or HIVAC for additional air movement. These are two examples of when a respirator should absolutely be worn.

On the other hand, a respirator would not be mandatory if the unit is operated outdoors or in a well ventilated area and the operator is 'upwind' of the exhaust port during puncturing or when opening the lid to insert or remove cans.

We appreciate your understanding of our position and please let us know if we may assist in satisfying your requirements.

Sincerely,

Ray Krebs

General Manager



1700 Jasper St. Unit F, Aurora, CO 80011 T 800.624.6706 F 303.364.7796 • Newstripe.com

Table of Contents / 4700.1117

AeroVent® 1X

TABLE OF CONTENTS

Precautionary Warning	Page 1
Assembly.....	Page 2
Assembly Drawing.....	Page 3
Parts List.....	Page 3
Operation.....	Page 4
Maintenance	Page 5
Cobalt Point Replacement.....	Page 5
Safe2Vent® Replacement.....	Page 5
Warranty.....	Page 6

Thank you and congratulations on your purchase of the AeroVent® 1X aerosol can disposal system.

The AeroVent® 1X has been designed to puncture and drain aerosol cans that have been used and are mostly empty. It is not intended to continuously process full cans.

Please read over the instructions and make sure you understand operating procedures before using the unit.



1700 Jasper St. Unit F, Aurora, CO 80011 T 800.624.6706 F 303.364.7796 • Newstripe.com

Table of Contents / 4700.1117

AeroVent® 1X

ALWAYS wear appropriate personal protective equipment when operating the unit!



- Always consult your facility safety manager for specified safety protocols prior to operating this equipment.
- Please read and understand all operation instructions as detailed in this manual. Failure to follow specified instructions may result in equipment damage or serious injury to personnel, including death.
- Always refer to the Product SDS for specific chemical handling and safety instructions prior to deflating aerosol cans.
- Liquids collected into drums may contain highly flammable liquid and vapor. Keep away from heat, sparks and flame – No smoking near the unit or drum.
- Take precautionary measures against static discharge. Ensure the grounding cable is attached to a suitable grounding source such as a metal water pipe or grounding rod.
- Keep the container closed when not in use.
- Store in a cool, well-ventilated area away from heat and ignition sources.
- Use only in a well-ventilated area.
- Avoid contact with eyes, skin, and clothing.
- Wear appropriate personal protective equipment; avoid direct contact with aerosol can contents.

CAUTION: Use of filters not specifically designed for the AeroVent® Aerosol Can Disposal Systems may result in dangerous back-pressure inside the recovery drum, resulting in equipment damage or serious injury to personnel, including death.

- Always refer to the Product Safety Data Sheet to check chemical compatibility when multiple aerosols are to be co-mingled in the same collection drum.
- Caustics, pesticides, insecticides, and white metals should not be collected into a drum with other liquid residuals and should be segregated into properly-labeled designated containers. Contact your waste handler for more information.



1700 Jasper St. Unit F, Aurora, CO 80011 T 800.624.6706 F 303.364.7796 • Newstripe.com
AeroVent® 1X Manual / 4700.0117

AeroVent® 1X

ALWAYS wear appropriate personal protective equipment when operating the unit!

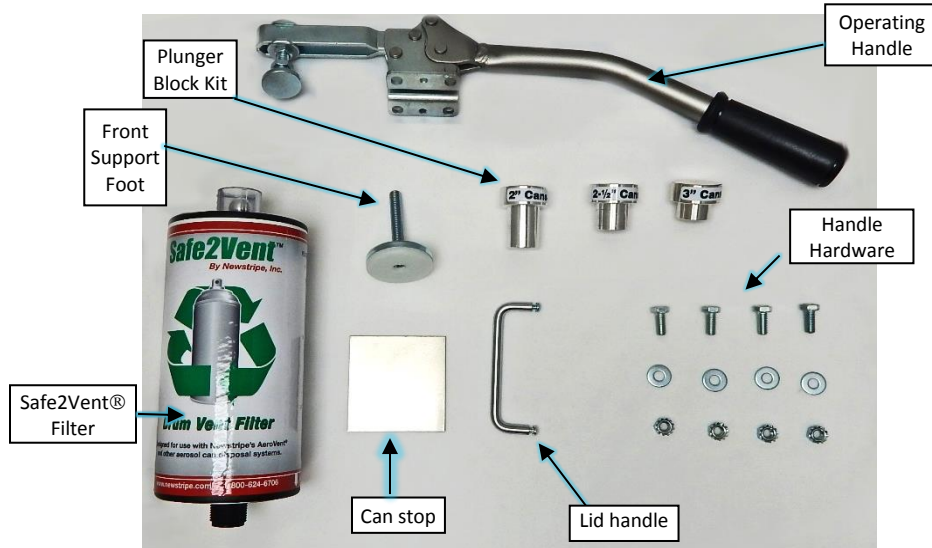

- Included Parts:**
- AeroVent®1X unit with ground cable
 - Operating Handle
 - Safe2Vent® Drum Filter
 - Handle Hardware: Bolts (4), Washers (4), Nuts (4)
 - Plunger Block Kit (3)
 - Can Stop
 - Lid Handle
 - Front Support Foot

- Tools needed for assembly:**
(Not included)
- (2) 1/2" wrenches.
 - (1) Philips head screwdriver

ASSEMBLY

1. Install the front support foot in the base of the unit.
2. Remove the 2" bung cap from an empty 30 or 55 gallon recovery drum. Insert the threaded nipple of the AeroVent® 1X into the opening and turn the unit until it is hand tight. The rear support foot should be located just inside the rim of the drum (the "chime").
3. Adjust the rear support foot clockwise until it is snug to the top of the drum. Then, adjust the front support foot until it is tight to the chime.
4. Open the lid and let it rest against the back stop. Remove the two screws from the lid handle. Position the lid handle on top of the lid and tighten the two screws from the underside of the lid.
5. Place the operating handle on the mounting plate so that the holes are aligned. Insert one bolt (with washer) through each hole. Loosely install one locking nut onto each bolt, but do not tighten yet. (Figure 1)
6. Place one of the plunger blocks into the hole on the closed lid assembly. Lower the operating handle so that it is centered side-to-side on the plunger block. Tighten all nuts and bolts of the operating handle assembly to the mounting plate at this time. (Figure 2)
7. Install the can stop in the slots at the front of the trough liner.
8. Remove the 3/4" bung cap from the top of the recovery drum and thread the Safe2Vent® filter unit into place. Hand-tighten only! **Note:** Remove the plastic packaging completely before installing the Safe2Vent® Filter.

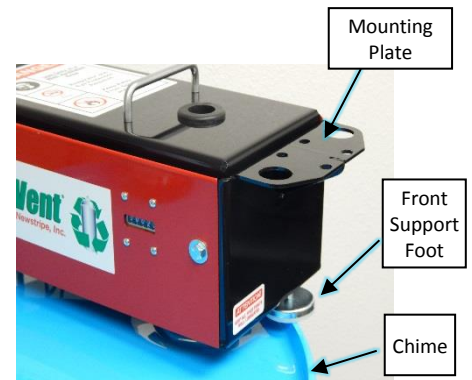

FIGURE 1



FIGURE 2



1700 Jasper St. Unit F, Aurora, CO 80011 T 800.624.6706 F 303.364.7796 • Newstripe.com
AeroVent® 1X Manual / 4700.0117

AeroVent® 1X

ALWAYS wear appropriate personal protective equipment when operating the unit!

- Attach the clamp end of the grounding cable to a suitable grounding source, such as a metal water pipe or grounding rod.

ASSEMBLY DRAWING

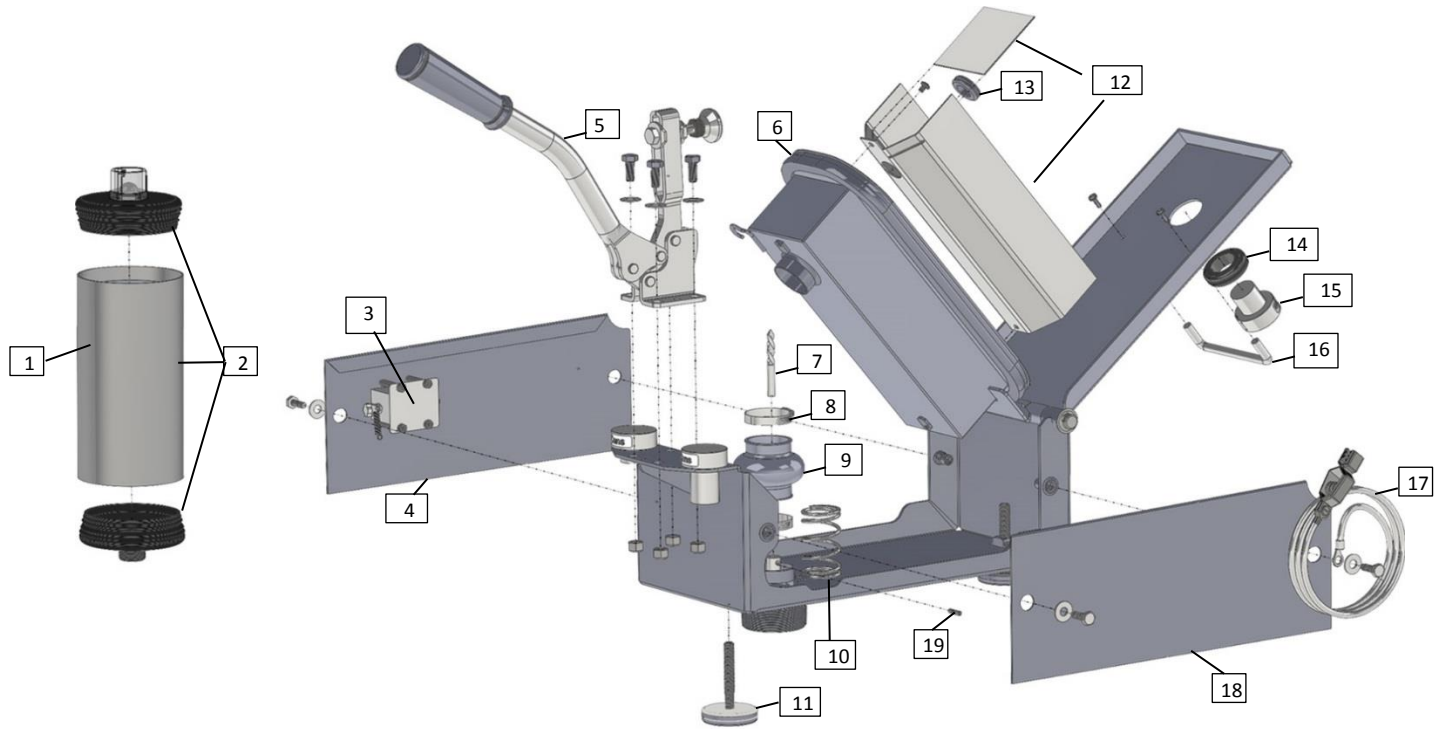

PARTS LIST

ITEM NUMBER	DESCRIPTION	PART NUMBER
1.	Safe2Vent® replacement element Package of 2	10004703
2.	Safe2Vent® Drum Filter	10004701
3.	Counter	10004716
4.	Left Shroud	10004729
5.	Operating Handle w/swivel foot	10004208
6.	Lid Gasket	10004249
7.	Cobalt Point	10003377
8.	Bellows Clamp (2 required)	10003794
9.	Bellows	10003791
10.	Trough Spring	10004257

ITEM NUMBER	DESCRIPTION	PART NUMBER
11.	Support Foot (2 required)	10004262
12.	Trough Liner w/can stop	10003970
13.	Trough Liner Grommet 4pk	10002202
14.	Lid Grommet	10002410
15.	Plunger Block Kit (2", 2.5" and 3")	10004248
16.	Lid Handle	10004195
17.	Grounding Cable w/clamp	10003914
18.	Right Shroud	10004287
19.	Set Screw 10-32 x 5/8"	10004167



1700 Jasper St. Unit F, Aurora, CO 80011 T 800.624.6706 F 303.364.7796 • Newstripe.com
AeroVent® 1X Manual / 4700.0117

AeroVent® 1X

ALWAYS wear appropriate personal protective equipment when operating the unit!

OPERATION

1. Using the can guide on the side of the unit, select the proper plunger block (2", 2.5", or 3").
2. Lift the operating handle to release the clamp, and open the AeroVent® 1X lid.
3. The can stop should be in the slots at the front of the trough liner.
4. Insert one aerosol can with **the bottom of the can pointing toward the clamp**, flush against the can stop.
5. Close the lid. Pushing down on the operating handle will clamp the lid down and engage the puncture mechanism.
6. The aerosol can has now been punctured and is draining. Wait 15-30 seconds and confirm the Viz-a-Ball™ has stopped moving to ensure the can is completely drained. You may now lift the handle and open the lid to remove the can.

Note: If aerosol cans are mostly full, leave the handle in the locked position for 45-60 seconds to allow the can to drain completely.



PRECAUTIONARY WARNING!



- Do not use the AeroVent®1X for draining expanding foam sealant aerosol products or spray adhesive products.
- Always use the correct Plunger Block for the diameter of the can that you are draining.
- The clamp must remain locked until the can is fully drained.
- To ensure that the can is drained, wait 15-30 seconds and confirm the Viz-a-Ball™ indicator on the drum filter has stopped, before un-locking the clamp and opening the lid.
- If a can is full when punctured, wait at least one minute before opening the unit. Full cans take longer to empty and may discharge fumes or liquids if the unit is opened too soon.
- We recommend changing the carbon filter every 90 days or 600 cans. If cans contain larger amounts of remaining liquids, change the filter more often. Also, we do not recommend allowing the drum to become more than 2/3 full. An air space is needed in the drum to allow for draining and venting of fumes.



1700 Jasper St. Unit F, Aurora, CO 80011 T 800.624.6706 F 303.364.7796 • Newstripe.com
AeroVent® 1X Manual / 4700.0117

AeroVent® 1X

ALWAYS wear appropriate personal protective equipment when operating the unit!

MAINTENANCE

ITEM	CHECK	ACTION
Lid Gasket 10004249	Before each use	Replace As Necessary
Safe2Vent®Element 10004702 (single) 10004703 (2 pk)	Monthly	Replace Every 90 days or 600 cans, more often for full cans
Cobalt Point 10003377	Before each use	Replace As Necessary
Bellows 10003791	Every 180 days	Replace As Necessary
Trough Grommet 10001874	Before each use	Replace As Necessary
Operating Handle. 10004208	Before each use	Lubricate regularly with light oil. (3-in-1, WD-40 etc.)

COBALT POINT REPLACEMENT

(See Assembly Drawing Page 3)

HELPFUL HINT: Leave the unit mounted on the drum to replace the cobalt point.

1. Open the lid and remove the left and right shrouds. Use caution when removing the left shroud to avoid damaging the counter-indexing spring. Disconnect the spring from the trough hook.
2. Loosen the bottom clamp on the bellows. There is no need to loosen the top bellows clamp, unless the bellows is damaged and needs to be replaced.
3. Lift the trough assembly upward and allow it to rest against the lid (the bellows may have to be gently pried off of the lower bellows tube to rotate the assembly up).
4. Loosen the setscrew with a 3/32" hex key and replace the point. Tighten the setscrew against the new point.
5. Re-assemble the unit in the reverse order of the steps above.

SAFE2VENT® REPLACEMENT

1. Remove the filter cap with Viz-a-Ball™ from the filter element.
2. Lift off the filter element from the filter base.
3. Install the new element onto the filter base.
4. Replace the filter cap with Viz-a-Ball™ by pressing it into the top of the element.
5. Dispose of the used filter element appropriately.
6. To reset the counter, remove the left shroud and carefully disconnect the counter-indexing spring. Rotate the reset knob counter-clockwise, reconnect the spring and install the shroud.



1700 Jasper St. Unit F, Aurora, CO 80011 T 800.624.6706 F 303.364.7796 • Newstripe.com

AeroVent® 1X Manual / 4700.0117

AeroVent® 1X

ALWAYS wear appropriate personal protective equipment when operating the unit!

THE NEWSTRIPE WARRANTY – 18 MONTH

NEWSTRIPE, INC., WARRANTS TO THE ORIGINAL PURCHASER, FOR 18 (EIGHTEEN) MONTHS AFTER DATE OF PURCHASE, THAT THE EQUIPMENT* HEREBY SOLD SHALL BE FREE OF DEFECTS IN MATERIALS AND WORKMANSHIP. THIS WARRANTY DOES NOT EXTEND TO ANY DAMAGE OR MALFUNCTION RESULTING FROM MISUSE, NEGLIGENCE, ACCIDENT, IMPROPER OPERATION, OR NORMAL WEAR AND TEAR.

Damage incurred in shipment from Newstripe, Inc. to the customer is the total responsibility of the carrier. The CUSTOMER MUST NOTE DAMAGES on the Bill of Lading from the trucking company or railroad, and Newstripe, Inc. will furnish to the customer the cost of parts and labor. The customer can then bill the common carrier for the damages by placing his or her signature on the documents.

The Newstripe, Inc. obligation under this warranty and any implied warranties is limited to replacement or repair of defective parts of its manufacture without charge for 18 (Eighteen) months from date of purchase. For service under this warranty, buyer shall ship the defective part or parts of the equipment, transportation prepaid, to Newstripe, Inc. together with a written description of any claimed defect and proof of purchase date of the materials being returned. **Prior to returning any part or machine, the CUSTOMER must obtain a Return Materials Authorization number. Call 1-800-624-6706. To review the complete guidelines for warranty and returns, please visit www.newstripe.com.**

The responsibilities described above are the only responsibilities of Newstripe, Inc. under this written warranty or any implied warranty, and may be exercised only within 18 (Eighteen) months from the date of purchase. In no event shall Newstripe, Inc. be liable for incidental or consequential damages and no person has any authority to bind it to any representation or warranty, responsibility for work done, materials furnished or repairs made by others without Newstripes' specific written authorization.

THIS WARRANTY SHALL BE IN LIEU OF ANY AND ALL OTHER WARRANTIES, EXPRESSED OR IMPLIED, INCLUDING ANY WARRANTIES OF MERCHANTABILITY OR FITNESS FOR A PARTICULAR PURPOSE, AND THERE IS NO OTHER REPRESENTATION OR WARRANTY OF ANY KIND WITH RESPECT TO THE GOODS SOLD HEREBY EXCEPT AS SET FORTH HEREIN. IT IS EXPRESSLY AGREED THAT THIS WARRANTY SHALL BE LIMITED TO THE ADJUSTMENT, REPAIR OR REPLACEMENT OF PARTS AND THE LABOR AND SERVICES REQUIRED THEREBY. IN NO EVENT, INCLUDING ANY CLAIM FOR NEGLIGENCE, SHALL NEWSTRIPE, INC. BE LIABLE FOR INCIDENTAL OR CONSEQUENTIAL DAMAGES.

Sincerely,
Newstripe, Inc.



1700 Jasper St. Unit F, Aurora, CO 80011 T 800.624.6706 F 303.364.7796 • Newstripe.com

AeroVent® 1X Manual / 4700.0117