



Stainless Solid

Key Features

- Makes clear cubes approx. 7/8" W x 7/8" H x 7/8" L
- Produces up to 60 lb of ice per day
- Stores up to 30 lb of ice
- Digital touch pad control with blue LED display
- U-Choose™ feature offers five levels of ice fullness
- Silent setting temporarily suspends ice making for 3 hours
- Indicator alert notifies user when cleaning is needed
- Easiest clear ice machine cleaning process in the industry
- Bright white LED lighting
- White interior
- Stainless steel cabinet, toe-kick, and full-wrap door
- Stainless steel handle (7/8" diameter)
- Field reversible door is shipped right-hand hinged
- Built-in or freestanding
- Four adjustable leveling legs
- Factory installed drain pump model recommended if a gravity drain is not accessible

Model Details

Model	Voltage/Hz	Door Swing	Pump	Finish	Shipping Weight
UOCL115-SS01A	115 / 60	Field Reversible	-	Stainless Solid	96 lb
UOCP115-SS01A	115 / 60	Field Reversible	Pump Included	Stainless Solid	101 lb

Accessories

Model	Description	Finish	Shipping Weight
80-54081-00	Clear Ice Machine Cleaner (1 box of 60 packets)	N/A	1 lb
80-54147-00	Drain Pump	N/A	7 lb
80-54674-00	Braided Water Supply Line Kit	N/A	2 lb

Dimensions

Front

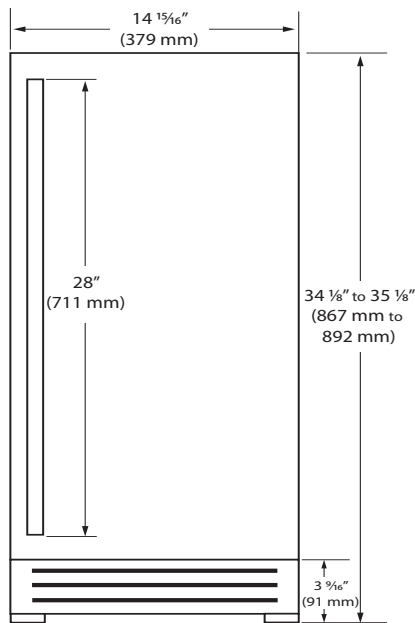

Side

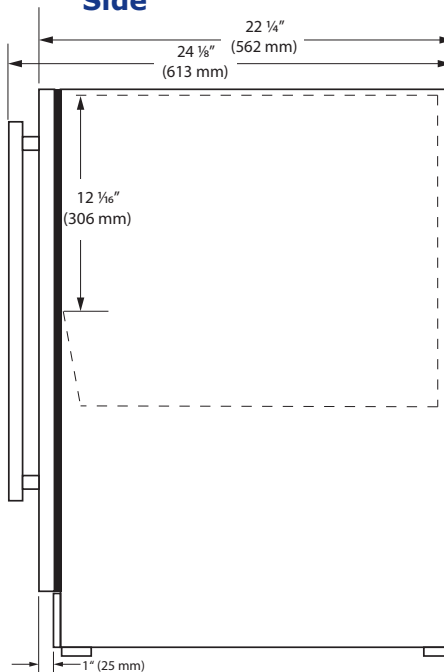

Top

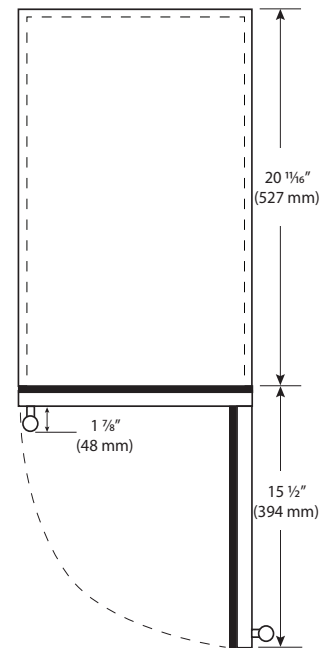

Specifications

Model	OCL115
Amps: Running	4
Amps: Ice Harvest	5.5
Dimensions: Product Depth	22 1/4" / 562 mm
Dimensions: Product Height	34 1/8" / 867 mm
Dimensions: Product Width	14 15/16" / 379 mm
Energy Consumption: Avg. Per Year	N/A
ENERGY STAR	N/A
Ice Production Per Day	60 lb
Ice Storage	30 lb
Product Weight: Max	101 lb
Refrigerant Type:	R134a
Sabbath (Star K Certified)	No

Back

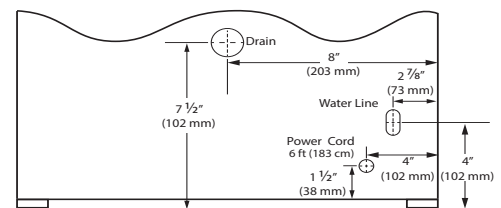

Cabinet Cut-Out

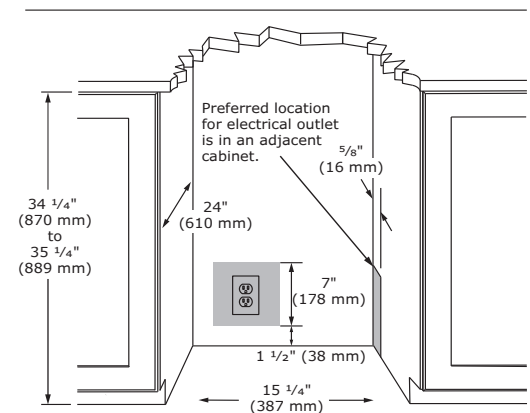

Warranty

- 1 Year (parts & labor) / 5 year sealed system (parts)
- **2 Year (parts & labor) / 5 year sealed system (parts) upgrade at no cost with product registration**



See complete warranty for details

Installation Notes

- 15" cutout width sufficient if door protrudes beyond adjacent cabinetry
- No additional clearance is needed for ventilation
- Do not obstruct front grille air flow



Please visit u-line.com to view this model's User Guide & Service Manual. All Specifications are subject to change without notice.