

FREESTANDING

# FIREPITS, FIRE TABLES, & DESIGNER FIREPLACES



Okinawa Resort, Japan  
Model: Ayre

ecosmart<sup>™</sup>  
Fire













# FREESTANDING

## SPECIFICATIONS

COMPATIBLE BURNERS*	AB8	AB3	BK5
<b>Fuel Capacity</b>	8 Litres [2.1 Gallons]	2.5 Litres [0.7 Gallons]	5 Litres [1.3 Gallons]
<b>Heats on Average</b>	Over 60m <sup>2</sup> [645ft <sup>2</sup> ]	Over 20m <sup>2</sup> [215ft <sup>2</sup> ]	Over 35m <sup>2</sup> [376.7ft <sup>2</sup> ]
<b>Approx. Burn Time</b>	7 - 11 hours	8 - 11 hours	7 - 11 hours
<b>Minimum Room Size (per fireplace)</b>	116m <sup>3</sup> [4096ft <sup>3</sup> ]	40m <sup>3</sup> [1413 ft <sup>3</sup> ]	70m <sup>3</sup> [2472ft <sup>3</sup> ]
<b>Included Accessories</b> Operational accessories designed for safe and ergonomic fire ignition and extinguishing.	 AB8 Efficiency Ring	 AB3 Extension Spout	 Top Tray
	 Jerry Can	 Lighting Rod + Lighter	 Operations Manual
			 Black Glass Charcoal <sup>‡</sup> (If Applicable)

### ETHANOL FIREPITS

MIX 600		• † ¥	
MIX 850	• † ¥		
Stix		•	

### TRIPLE FUEL FIRE TABLES

POD40, POD30	• † ¥		
Martini	• † ¥		

### DESIGNER FIREPLACES

Ghost		•	
Igloo			•

\* The efficiency data outlined above is indicative only and may vary depending on the model purchased, weather conditions, installation and bioethanol used.

† This model comes with fixing brackets for permanently locating into a fixed position.

¥ Models come with decorative black glass charcoal.



MIX Fire Bowls



Stix



POD Series



Martini



Ghost



Igloo

FREESTANDING

# ETHANOL FIREPITS



Private Residence, Japan  
Model: Stix

ecosmar<sup>+</sup>  
Fire

Freedom, flexibility and eco-friendly functionality – EcoSmart’s freestanding bioethanol fireplaces add warmth, style and ambiance to living and entertaining spaces. Cleverly refashioning the traditional fireplace concept into a piece of portable fire furniture means that you can now enjoy the simple pleasures of an open fire in more places than ever before.

**Relocate With Ease**

Bioethanol outdoor fireplaces relocate with ease, and this portability is greatly enhanced by the self contained engineering of the EcoSmart system. There is no need for a utility connection, which means you can transform the look and feel of your outdoor entertaining area when desired.

Or, leave your fireplace in a permanent position on the patio and design an enchanting outdoor space using the fireplace as the focal point. It has never been this easy to design a backyard or courtyard that feels so inviting.

**Black Glass Charcoal**

The Black Glass Charcoal is made from high-quality tempered glass and has been designed to withstand harsh weather and temperatures of up to 1300°F/700°C without ever cracking, or losing its color or shape. Black Glass Charcoal does not emit any toxic fumes, smoke, or ash so it is extremely easy to maintain and clean.

**Colors**

Our concrete models come in three different colors: Natural, Graphite and Bone.



**Environmentally-Friendly**

Bioethanol fireplaces use an environmentally-friendly, renewable energy source that burns clean and delivers warming heat. You and your guests will enjoy the ambiance and tranquility of a real fire, without the hassles of burning real wood - no more embers, ash, and soot to clean up.

**Ground Fixing Brackets**

MIX Fire Bowls come with fixing brackets for permanently locating into a fixed position.

**Versatile and Incredibly Durable**

EcoSmart portable fireplaces are versatile, incredibly durable, and are constructed of heavy-gauge glass and weather resistant materials. These appliances are designed to look great for years, and will perform admirably through all four seasons.



Protective Covers



Tank Stool/Side Table

# MIX FIRE BOWLS



<b>Application</b>	Indoor & Outdoor	
<b>Materials</b>	Fluid Concrete Technology, Grade 304 Stainless Steel, Included Black Glass Charcoal	
<b>Weight</b>	53.6kg [118lbs] & 30.2kg [66.4lbs] Weight includes burner and black glass charcoal.	
<b>Model SKU's</b>	MIX 850 = ESF.2.O. <i>MX8</i> MIX 600 = ESF.2.O. <i>MX6</i>	
<b>Colours* &amp; SKU's</b>	<ul style="list-style-type: none"> <li><span style="display: inline-block; width: 15px; height: 15px; background-color: #333; margin-right: 5px;"></span> Natural</li> <li><span style="display: inline-block; width: 15px; height: 15px; background-color: #ccc; margin-right: 5px;"></span> Bone</li> <li><span style="display: inline-block; width: 15px; height: 15px; background-color: #000; margin-right: 5px;"></span> Graphite</li> </ul>	<ul style="list-style-type: none"> <li>ESF.2.O.(<i>model</i>).NA</li> <li>ESF.2.O.(<i>model</i>).BO</li> <li>ESF.2.O.(<i>model</i>).GH</li> </ul>
<b>Optional Accessories</b>	Protective Covers	

## BURNER INFORMATION\*

<b>MIX 850 Burner</b>	AB8
<b>Fuel Type</b>	e-NRG Bioethanol
<b>Fuel Capacity</b>	8 Litres [2.1 Gallons]
<b>Heats on Average (when used indoors)</b>	Over 60 square metres [645 square feet]
<b>Burn Time</b>	7 - 11 hours (approx)
<b>Minimum Room Size</b>	116 cubic metres [4096 cubic feet] per fireplace.

<b>MIX 600 Burner</b>	AB3
<b>Fuel Type</b>	e-NRG Bioethanol
<b>Fuel Capacity</b>	2.5 Litres [0.7 Gallons]
<b>Heats on Average (when used indoors)</b>	Over 20 square metres [215 square feet]
<b>Burn Time</b>	8 - 11 hours (approx)
<b>Minimum Room Size</b>	40 cubic metres [1413 cubic feet] per fireplace.

\* These values are indicative only and may vary depending on the model purchased, installation, and the seasonal resource used to manufacture e-NRG. This model comes with fixing brackets for permanently locating into a fixed position.



These models have manufacturer approved surrounds for the UL Listed AB8 and AB3 burners.

MIX 600 FRONT VIEW

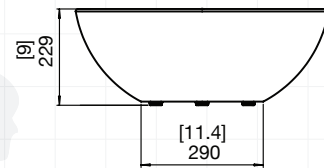

MIX 600 TOP VIEW

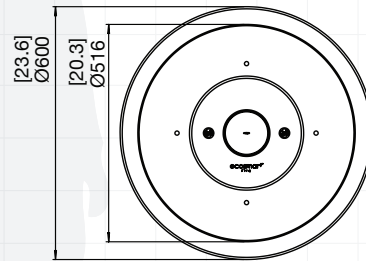

MIX 850 FRONT VIEW

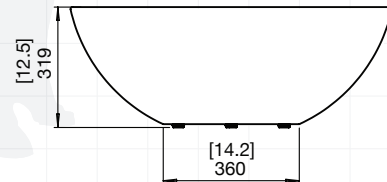

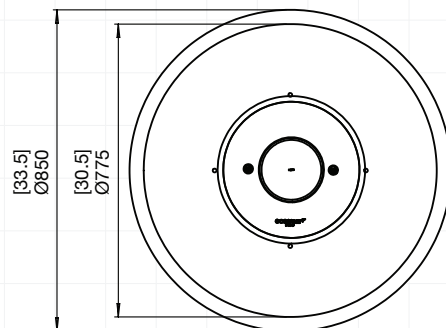

MIX 850 TOP VIEW

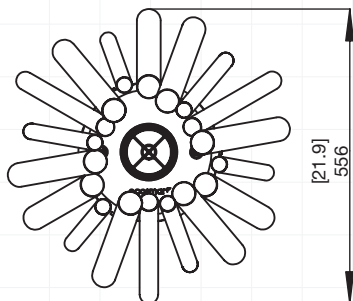
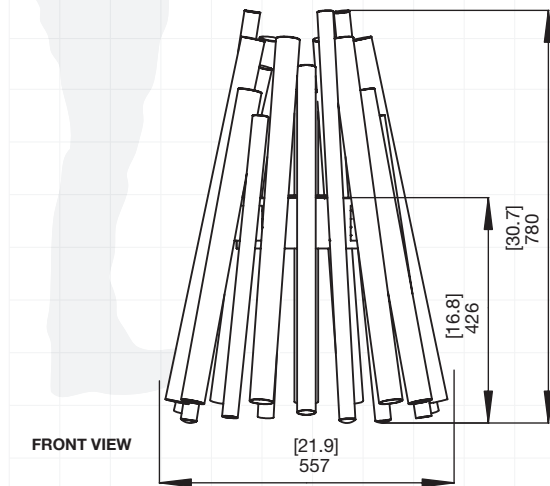

# STIX



<b>Awards</b>	2011 DesignEx Best New Product (AUS) 2011 IIDA/HD Award for Excellence (USA)							
<b>Application</b>	Indoor & Outdoor							
<b>Materials</b>	Grade 304 Stainless Steel, Mild Steel							
<b>Weight</b>	20.7kg [45.5lbs] Weight includes Burner.							
<b>Colours &amp; SKU's</b>	<table border="0"> <tr> <td></td> <td>Stainless Steel</td> <td>ESF.1.O.STX.SS</td> </tr> <tr> <td></td> <td>Black</td> <td>ESF.1.O.STX.BL</td> </tr> </table>		Stainless Steel	ESF.1.O.STX.SS		Black	ESF.1.O.STX.BL	
	Stainless Steel	ESF.1.O.STX.SS						
	Black	ESF.1.O.STX.BL						
<b>Optional Accessories</b>	Protective Cover							

## BURNER INFORMATION\*

<b>Burner</b>	AB3
<b>Fuel Type</b>	e-NRG Bioethanol
<b>Fuel Capacity</b>	2.5 Litres [0.7 Gallons]
<b>Heats on Average (when used indoors)</b>	Over 20 square metres [215 square feet]
<b>Burn Time</b>	8 - 11 hours (approx)
<b>Minimum Room Size</b>	40 cubic metres [1413 cubic feet] per fireplace.

\* These values are indicative only and may vary depending on the model purchased, installation, and the seasonal resource used to manufacture e-NRG.



This model is a manufacturer approved surround for the UL Listed AB3 burner.



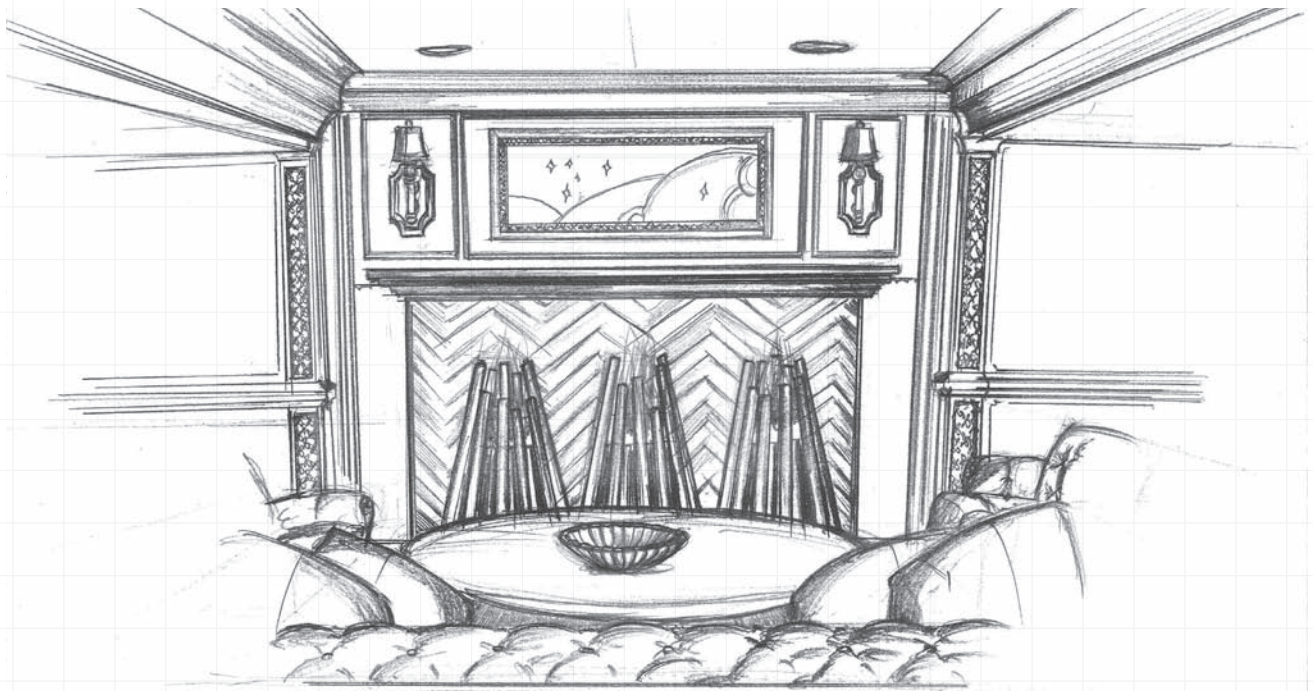

*Brief: Use materials and furnishings in unexpected ways to achieve a theatrical feel in the Allegro Hotel's third floor lounge and meeting room.*

*Solution: Stix*



**Allegro Hotel, Chicago USA**

**Model: Stix x 3**

Drama, glamour, music and movement – these are just some of the theatrical elements the award-winning Simeone Deary Design Group captured in their re-design of the boutique Allegro Hotel in the heart of downtown Chicago.



Read more about this case study at [ecosmartfire.com](http://ecosmartfire.com)



# FREESTANDING TRIPLE FUEL FIRE TABLES



Private Residence  
Model: Martini

ecosmart<sup>+</sup>  
Fire

This multi-function table gives you the best of both worlds – a coffee table and fire pit combined. Our Triple Fuel Advantage (NG/LP/Ethanol) combined with Fluid Concrete Technology delivers an unmatched fire solution suitable for indoor and outdoor settings.

**Optional Fire Screens**

Pair with a toughened glass fire screen, which stabilises the flame in windy conditions.

**Functional Table Space**

Standing 300mm [12"] tall with a substantial 1,270mm [50"] length, Martini features generous space for accommodating food and drinkware.

**Black Glass Charcoal**

The Black Glass Charcoal is made from high-quality tempered glass and has been designed to withstand harsh weather and temperatures of up to 1300°F/700°C without ever cracking, or losing its color or shape. Black Glass Charcoal does not emit any toxic fumes, smoke, or ash so it is extremely easy to maintain and clean.

**Colors**

Our concrete models come in three different colors: Natural, Graphite and Bone.

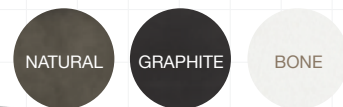

**Versatile and Re-locatable**

When you select Bioethanol or Liquid Propane as your fuel source you'll never be tied down! With zero hard utility connections, relocating your fire is a breeze. Entertain on your own terms with EcoSmart Fire.

**Fluid Concrete Technology**

Featuring a stain and impact-resistant barrier that protects the concrete from environmental weathering – even under extreme conditions and long UV exposure.

**Triple Fuel Advantage**

Choose between plumbed natural gas, readily available propane, or our eco-friendly bioethanol fuel system. We make it easy for you to achieve exactly what you want, for exactly where you want it.

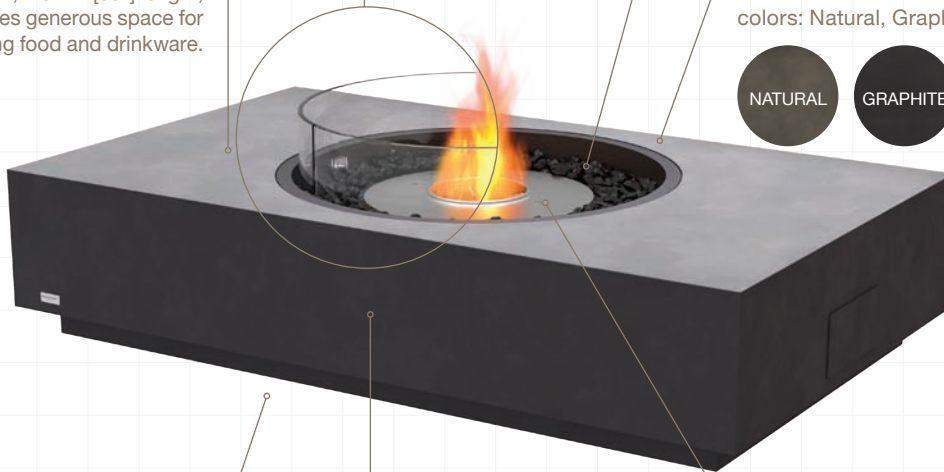

Fire Screens



Protective Covers



Tank Stool/Side Table



# MARTINI

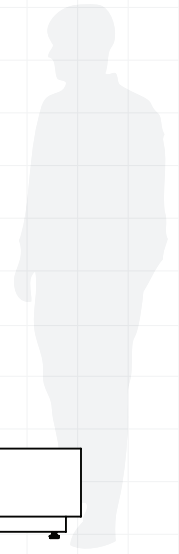

<b>Application</b>	Indoor & Outdoor		
<b>Awards</b>	Hearth & Home VESTA Award 2018		
<b>Materials</b>	Fluid Concrete Technology, Grade 304 Stainless Steel, Included Black Glass Charcoal		
<b>Weight</b>	55.9kg [123.1lbs] Weight includes burner and black glass charcoal.		
<b>Colors &amp; SKU's</b>	<b>LP/NG</b>	■ Natural	ESF.1.O.MTI.NA.G
		■ Bone	ESF.1.O.MTI.BO.G
		■ Graphite	ESF.1.O.MTI.GH.G
	<b>Bioethanol</b>	■ Natural	ESF.1.O.MTI.NA.E
		■ Bone	ESF.1.O.MTI.BO.E
		■ Graphite	ESF.1.O.MTI.GH.E
<b>Optional Accessories</b>	Fire Screen, Protective Cover, Tank		

FUEL OPTIONS	BTU/HR	BURN HOURS*
Liquid Propane	55,000	8 - 20
Natural Gas	55,000	Unlimited
Bioethanol	20,000	7 - 11

\* These Values are Indicative only.  
This model comes with fixing brackets for permanently locating into a fixed position.



This model is a manufacturer approved surround for the UL Listed AB8 burner.

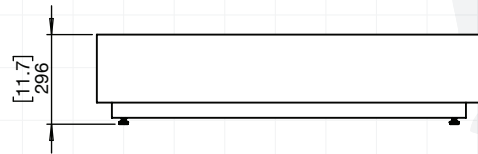

FRONT VIEW

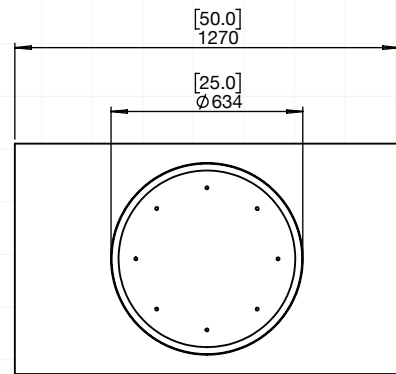

TOP VIEW

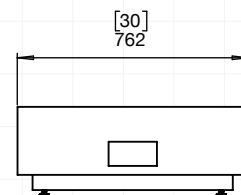

# POD SERIES

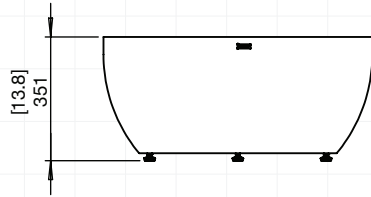

POD30  
FRONT VIEW

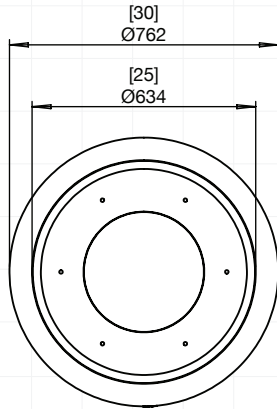

POD30  
TOP VIEW

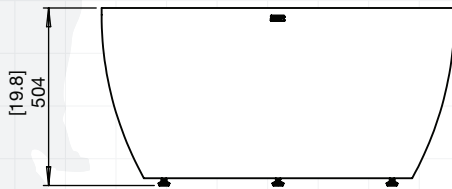

POD40  
FRONT VIEW

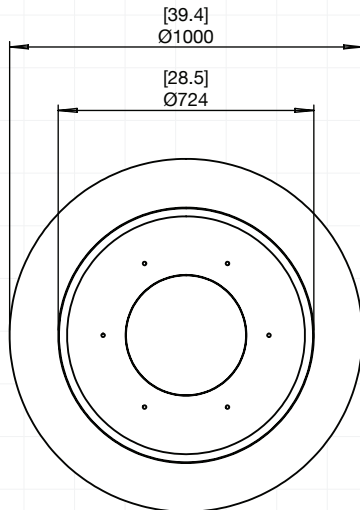

POD40  
TOP VIEW

<b>Application</b>	Indoor & Outdoor										
<b>Awards</b>	Hearth & Home VESTA Award 2018										
<b>Materials</b>	Fluid Concrete Technology, Grade 304 Stainless Steel, Included Black Glass Charcoal										
<b>Weight</b>	42.9kg [94.5lbs] & 53.9kg [118.7lbs] Weight includes burner and black glass charcoal.										
<b>Model SKU's</b>	POD30 = ESF.1.O. <b>PD3</b> POD40 = ESF.1.O. <b>PD4</b>										
<b>Colors &amp; SKU's</b>	<b>LP/NG</b>	<table border="0"> <tr> <td></td> <td>Natural</td> <td>ESF.1.O.(<i>model</i>).NA.G</td> </tr> <tr> <td></td> <td>Bone</td> <td>ESF.1.O.(<i>model</i>).BO.G</td> </tr> <tr> <td></td> <td>Graphite</td> <td>ESF.1.O.(<i>model</i>).GH.G</td> </tr> </table>		Natural	ESF.1.O.( <i>model</i> ).NA.G		Bone	ESF.1.O.( <i>model</i> ).BO.G		Graphite	ESF.1.O.( <i>model</i> ).GH.G
	Natural	ESF.1.O.( <i>model</i> ).NA.G									
	Bone	ESF.1.O.( <i>model</i> ).BO.G									
	Graphite	ESF.1.O.( <i>model</i> ).GH.G									
	<b>Bioethanol</b>	<table border="0"> <tr> <td></td> <td>Natural</td> <td>ESF.1.O.(<i>model</i>).NA.E</td> </tr> <tr> <td></td> <td>Bone</td> <td>ESF.1.O.(<i>model</i>).BO.E</td> </tr> <tr> <td></td> <td>Graphite</td> <td>ESF.1.O.(<i>model</i>).GH.E</td> </tr> </table>		Natural	ESF.1.O.( <i>model</i> ).NA.E		Bone	ESF.1.O.( <i>model</i> ).BO.E		Graphite	ESF.1.O.( <i>model</i> ).GH.E
	Natural	ESF.1.O.( <i>model</i> ).NA.E									
	Bone	ESF.1.O.( <i>model</i> ).BO.E									
	Graphite	ESF.1.O.( <i>model</i> ).GH.E									

**Optional Accessories** Fire Screen, Protective Cover, Tank

FUEL OPTIONS	BTU/HR	BURN HOURS*
<b>Liquid Propane</b>	55,000	8 - 20
<b>Natural Gas</b>	55,000	Unlimited
<b>Bioethanol</b>	20,000	7 - 11

\* These Values are Indicative only.

This model comes with fixing brackets for permanently locating into a fixed position.



This model is a manufacturer approved surround for the UL Listed AB8 burner.



FREESTANDING

# DESIGNER FIREPLACES



Commercial Space, Japan  
Model: Igloo

ecosmart<sup>+</sup>  
Fire

EcoSmart Fire's Designer Fireplaces add amazing warmth and remarkable ambiance to all environments - without the fuss, without any building work, and without any mess.

**Portable Fireplace**

You'll have the ability to move these contemporary, stylish pieces of portable furniture from room to room. Or, relocate your bioethanol fireplace from inside your residence to the outside during parties or festivities and store away through the warmer months if space is an issue. And take it with you if you move house!

**No Flue, No Chimney,  
No Electricity Connection**

Our freestanding fireplaces offer an easy and immediate, environmentally friendly solution to adding warmth and ambiance to any location.

**Glass Surround**

Made with Toughened Glass.

**Stainless Steel**

Burner Shelf and Burners come in Stainless Steel.

**Decorative Steel Logs**

EcoSmart Fire offers non-combustible logs as an optional, eye-catching accessory for the Ghost. Made from stainless steel with a patina finish, they are available in different finishes.

**Quick and Easy**

With no installation or building works required, simply unpack, put into position, and off you go.



Fire Screens



Decorative Steel Logs



# GHOST



<b>Application</b>	Indoor & Outdoor
<b>Materials</b>	Grade 304 Stainless Steel, Toughened Glass
<b>Weight</b>	33.1kg [72.9lbs] Weight includes burner.
<b>Colour &amp; SKU</b>	 Stainless Steel ESF.1.D.GST
<b>Optional Accessories</b>	Attachable Fire Screen, Decorative Steel Logs**

## BURNER INFORMATION\*

<b>Burner</b>	AB3
<b>Fuel Type</b>	e-NRG Bioethanol
<b>Fuel Capacity</b>	2.5 Litres [0.7 Gallons]
<b>Heats on Average (when used indoors)</b>	Over 20 square metres [215 square feet]
<b>Burn Time</b>	8 - 11 hours (approx)
<b>Minimum Room Size</b>	40 cubic metres [1413 cubic feet] per fireplace.

\*These values are indicative only and may vary depending on the model purchased, installation, and the seasonal resource used to manufacture e-NRG.

\*\*Decorative logs must NOT be placed directly over an open flame. They are designed to sit near heat but not over flames.

Logs not included.

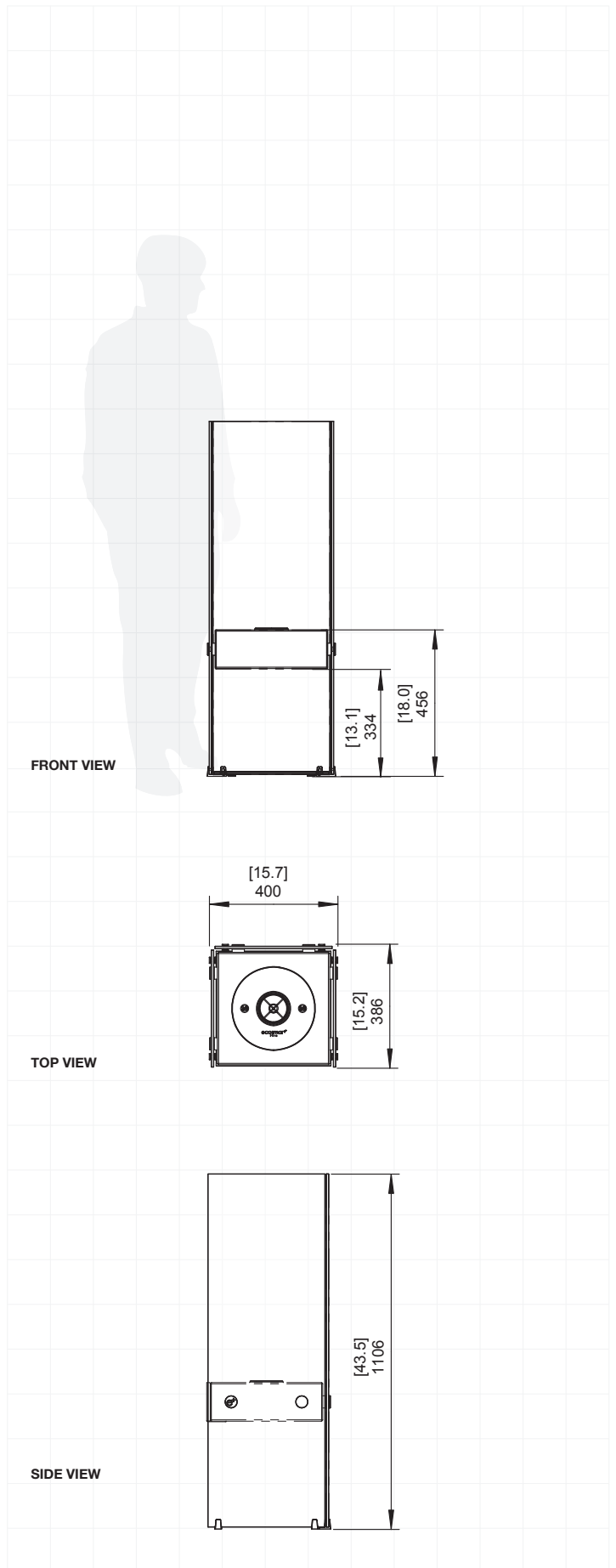

# IGLOO

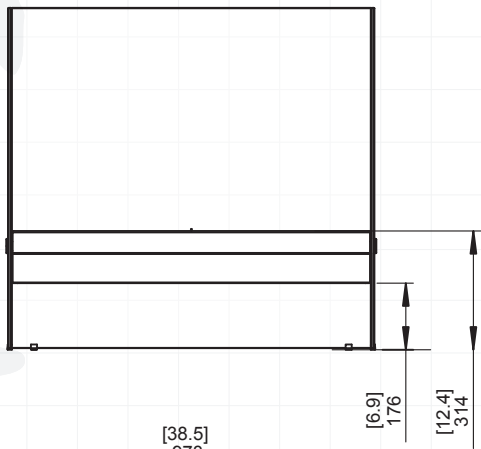

FRONT VIEW

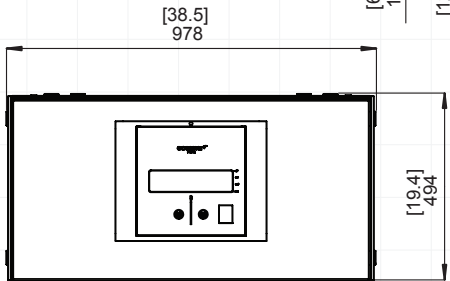

TOP VIEW

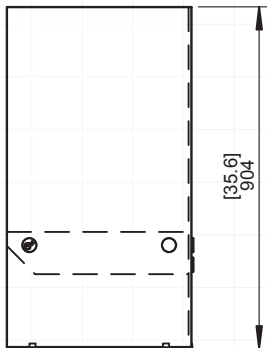

SIDE VIEW

<b>Application</b>	Indoor & Outdoor
<b>Materials</b>	Grade 304 Stainless Steel, Toughened Glass
<b>Weight</b>	54.1kg [118.9lbs] Weight includes burner.
<b>Color &amp; SKU</b>	■ Stainless Steel ESF.1.D.IGL
<b>Optional Accessories</b>	Plasma Fire Screen, Decorative Steel Logs

## BURNER INFORMATION

<b>Burner</b>	BK5
<b>Fuel Type</b>	e-NRG Bioethanol
<b>Fuel Capacity</b>	5 Litres [1.3 Gallons]
<b>Heats on Average (when used indoors)</b>	Over 35 square metres [376.7 square feet]
<b>Burn Time</b>	7 - 11 hours (approx)
<b>Minimum Room Size</b>	70 cubic metres [2472 cubic feet] per fireplace.

\* These values are indicative only and may vary depending on the model purchased, installation, and the seasonal resource used to manufacture e-NRG.



This model is a manufacturer approved surround for the UL Listed BK5 burner.

ABOUT

# e-NRG BIOETHANOL FUEL



e-nrg<sup>®</sup>



Achieving a beautiful, vibrant flame in your bioethanol fireplace is easy when you use the right fuel.



### Lowest Odour

We use only the highest quality ingredients for the cleanest experience.



### Best Flame

e-NRG is specifically formulated to produce a vibrant orange flame.



### Clean Burning

Lose the chimney and the flue and keep the heat in - no smoke, no soot, no ash.



### Safety First

e-NRG bottles are fitted with a flame arrester and supported by an operational procedure to ensure it's used in the safest way.

Our bottles are fitted with a flame arrester for safe re-filling.



### Fast Refilling

e-NRG bottles pour 8x faster than the competition.

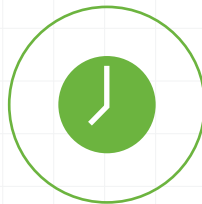

### Longest Burn Time

Tested against a multitude of formulas to ensure it burns for the longest time.

### Order Online

Conveniently delivered to your door.



### e-NRG

e-NRG is defining some of the most beautiful bioethanol fire installations across the globe.

[www.e-nrg.com](http://www.e-nrg.com)



ABOUT

# FLUID CONCRETE TECHNOLOGY



fluid™

EcoSmart fire features are synonymous with quality, substance and enduring style and now those same qualities can be applied to our extensive concrete collection.

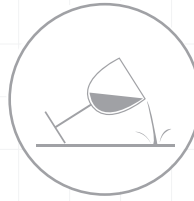

### Stain Resistant

Rigorous testing confirms the surface is impervious to ethanol, wine, vinegar, oil, mustard, tomato ketchup, salt, soy, bleach, espresso coffee, window cleaner, and more. \*Turmeric should be avoided.

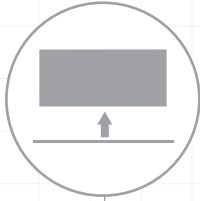

### Lightweight

Sturdy yet lightweight composition means that relocation is achievable.

### Custom Finish

Custom finishing process incorporating German technology delivers a smooth, natural satin surface.

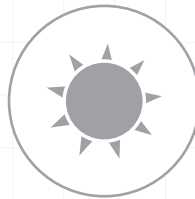
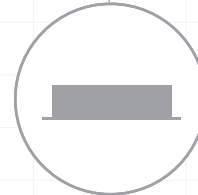

### UV Resistant

Even when our products were exposed for 144 hours in 12-hour cycles to water spray, UV rays, and water condensation, colours retained their depth and luster.

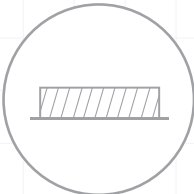

### Durable Surface

An exceptionally strong adhesion creates a coating that does not flake, peel or crack, and can withstand extreme weather variations and long UV exposure.



### Fluid

With Fluid™ Concrete Technology you're assured of high-quality, robust products that are incredibly strong.

[fluidconcrete.com](http://fluidconcrete.com)

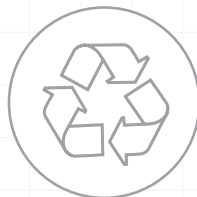

### Environmentally Friendly

Made from a combination of green cement and 95% recycled natural materials that absorb CO2 during the curing process, our composites are 100% recyclable and release minimal greenhouse gas emissions.



# ECO SMART FIRE .COM

ecosmar+™  
Fire

Reproduction of this catalogue in any manner, in any language, in whole or in part without prior written permission is prohibited. The Fire Company Pty Ltd reserves the right to correct any errors or misprints. All product specifications and data are subject to change without notice and believed to be correct at the time of publication. The Fire Company Pty Ltd, its affiliates, agents, and employees, and all persons acting on its or their behalf (collectively, "The Fire Company"), disclaim any and all liability for any errors, inaccuracies or incompleteness contained herein or in any other disclosure relating to any product. The Fire Company disclaims any and all liability arising out of the use or application of any product described herein or of any information provided herein to the maximum extent permitted by law. The product specifications do not expand or otherwise modify The Fire Company P/L's terms and conditions of purchase, including but not limited to the warranty expressed therein, which apply to these products. No license, express or implied, by estoppel or otherwise, to any intellectual property rights is granted by this document or by any conduct of The Fire Company. Customers using or selling The Fire Company products not expressly indicated for use in such applications do so entirely at their own risk and agree to fully indemnify The Fire Company for any damages arising or resulting from such use or sale. Please contact authorised personnel from The Fire Company to obtain written terms and conditions regarding products designed for such applications. International Patent Pending – Trademarks Pending – All Designs Registered. V0818