

X25-8.4-65-* Technical Specification

X25-12-65-*

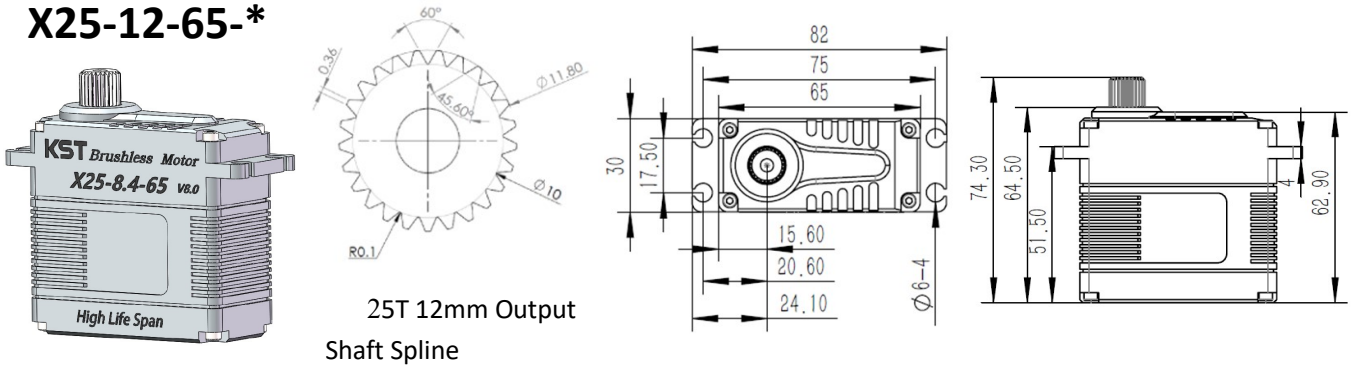

25T 12mm Output Shaft Spline

1. Operating Data

	X25-8.4-65-*	X25-12-65-*
Operation	DC8.4V	DC12.0V
Operation Voltage	DC6.0V-8.4V	DC9.0V-13V
Torque	6N.m@6.0V	7N.m@9V
	7N.m@7.4V	8.5N.m@12V
	7.8N.m@8.4V	9N.m@13V
Speed	0.24sec/60°@6.0V	0.32sec/60°@9V
	0.20sec/60°@7.4V	0.24sec/60°@12V
	0.18sec/60°@8.4V	0.23sec/60°@13V
Working Frequency	1520us/333Hz	
Default Travel Angle	± 50°=100°Total When 1000us-2000us	
Temperature Range	-10°C.....+65°C	
Case Material	Aluminum Alloy	
Motor Type	Brushless DC Motor	
Gear Set Material	Hardened Steel	
Position Sensor	Contactless	
Case Dimensions	65mm*30mm*64.5mm±0.2mm	
Weight	280g±10%	

2. Performance

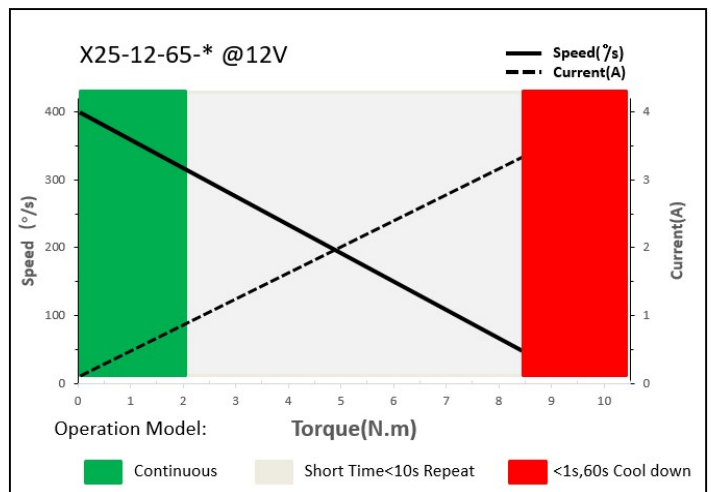
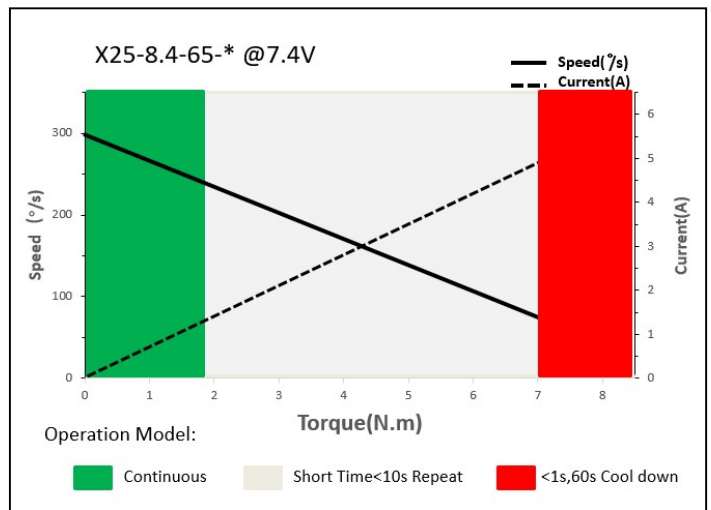

3. Command signal

3.1. PWM Command Interface

Signal Voltage	TTL-level: HIGH: min.3.3V, max.5.0V Low: min.0.0V, max.1.5V
Pulse Lengths	900us-2100us
Pulse Lengths for Position-50°/ 0°/+50°	1000us/1500us/2000us

3.2. RS485 Command Interface

Baud-Rate	115200 ±1.5% bits/s
Protocol (Documentation available)	10 Byte (incl. 1 byte Check Sum)

3.2.1. RS485 Protocol Specifications

Number of Data Bits	8
Number of Stop Bits	1
Parity	None

3.2.2. Command / Response Frame

Byte #	Description	Byte #	Description
1	Frame Head(0xFE)	6	Data
2	Version(0xCA)	7	Data
3	Address	8	Data
4	Command code	9	Check Sum
5	Data	10	(0A) Frame End

3.3. CAN Bus Command Interface

Baud-Rate	500Kbps
Node number	0 x25 (range 1 ~ 127, 0 is radio)
Communication	CAN Open standard frame format CAN Extended frame

3.4. Feedback Singnal

3.4.1. Position Feedback Signal (PWM Versions)

The Position Feedback signal is an output signal with a square wave which is directly related to the output shaft's angular position. Reference is Supply Ground.

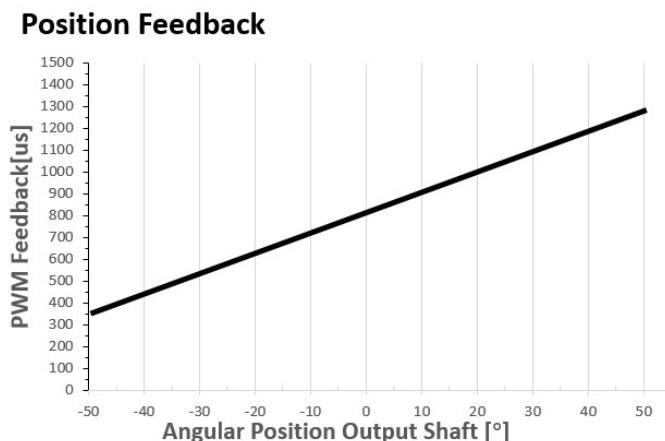
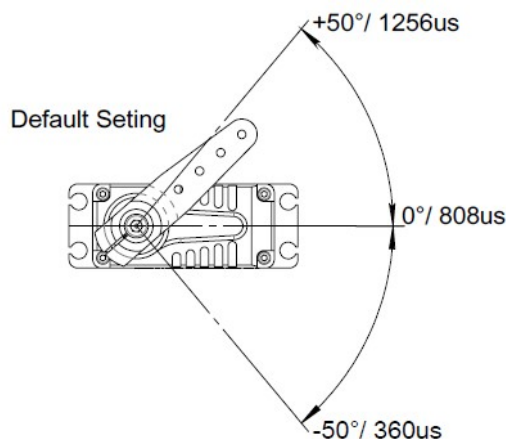

* Tolerance ±1%

4.4.2 Feedback Value (Bus Versions)



Integrated in the Bus protocol a Feedback Value, including the Angle position, Temperature, current value. Value read by sending request command. Provide the details of the bus in the document.

4. Electrical Connection Options

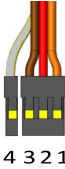
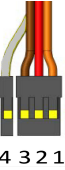
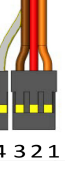
4.1. Standard Connector (Leads Length 300mm)

 <p>4 3 2 1</p>	Pin Assignment (PWM)			
	1	Yellow	SIG	Command Signal
	2	Red	DC+	Supply Voltage
	3	Brown	DC-(GND)	Supply Ground, Signal Ground
 <p>4 3 2 1</p>	Pin Assignment (RS485)			
	1	Yellow	RS485A	Non-Inverted Input / Output line
	2	Red	DC+	Supply Voltage
	3	Brown	DC-(GND)	Supply Ground, Signal Ground
 <p>4 3 2 1</p>	Pin Assignment (CAN_BUS)			
	1	Yellow	CAN_H	CAN high
	2	Red	DC+	Supply Voltage
	3	Brown	DC-(GND)	Supply Ground, Signal Ground
	4	white	CAN_L	CAN low

4.2. Shielded Cable, Open leads (Leads Length 1000mm)

	Pin Assignment(PWM)			
	1	Red	+V DC	Supply Voltage
	2	Black	GND	Supply Ground, Signal Ground
	3	White	SIG	Command Signal
	Pin Assignment (RS485)			
	1	Red	+VDC	Supply Voltage
	2	Black	GND	Supply Ground, Signal Ground
	3	White	RS 485 B	Inverted Input / Output line
	Pin Assignment (CAN_BUS)			
	1	Red	+VDC	Supply Voltage
	2	Black	GND	Supply Ground, Signal Ground
	3	White	CAN_L	CAN Low data
4	Blue	CAN_H	CAN High data	