

X15-1809 Technical Specification

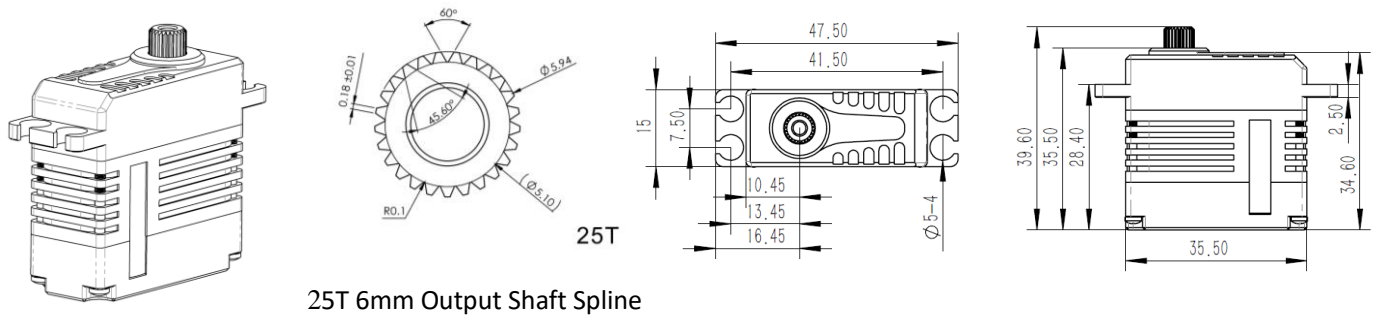

25T 6mm Output Shaft Spline

1. Operating Data

	X15-1809
Rated Voltage	DC7.4V
Voltage Range	DC6.0V-8.4V
Torque	18Kgf.cm@6.0V
	22Kgf.cm@7.4V
	24Kgf.cm@8.4V
Speed	0.09sec/60°@6.0V
	0.08sec/60°@7.4V
	0.07sec/60°@8.4V
Working Frequency	1520us/333Hz
Default Travel Angle	±50° = 100° Total
Temperature Range	-10°C+65°C
Soft Start	Programmable
Programmable	Yes
Case Material	Aluminum Alloy
Motor Type	Brushless DC Motor
Gear Set Material	Hardened Steel
Position Sensor	Potentiometer
Ball Bearing	2BB
Case Dimensions	35.5mm*15mm*35.5mm±0.2mm
Weight	45g±10%

2. Performance

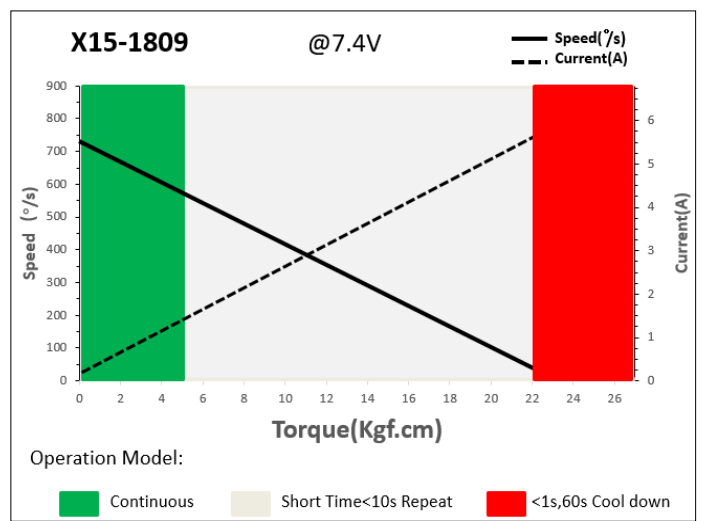

3. Command signal

PWM Command Interface

Signal Voltage	HIGH: min.3.3V, max.5.0V Low: min.0.0V, max.1.5V
Pulse Lengths	900us-2100us
Pulse Lengths for Position -50°/ 0°/+50°	1000us/1500us/2000us

4. Electrical Connection

<p>3 2 1</p>	Pin Assignment			
	1	Orange	Signal	PWM Command
	2	Red	DC+	Supply Voltage
	3	Brown	DC-	Supply Ground