

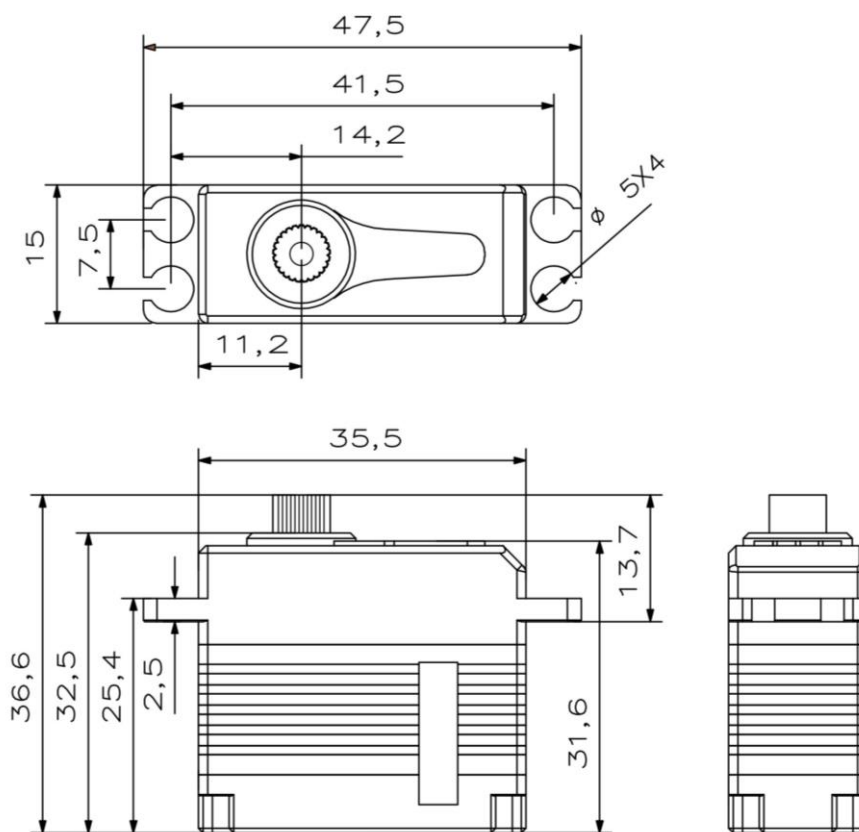

# X15-1208

## Technical Specification





## Operating Data

	<b>X15-1208</b>
<b>Operation Voltage(rated)</b>	DC7.4V
<b>Operation Voltage Range</b>	DC6.0V-8.4V
<b>Torque</b>	9.8Kg.cm@6.0V
	12Kg.cm@7.4V
	13.5Kg.cm@8.4V
<b>Speed</b>	0.10sec/60 °@6.0V
	0.08sec/60 °@7.4V
	0.07sec/60 °@8.4V
<b>Travel Angle</b>	±50° when 1000-2000us
<b>Operating Temperature Range</b>	-10°C……+65°C

## Performance

**X15-1208**

**@7.4V**

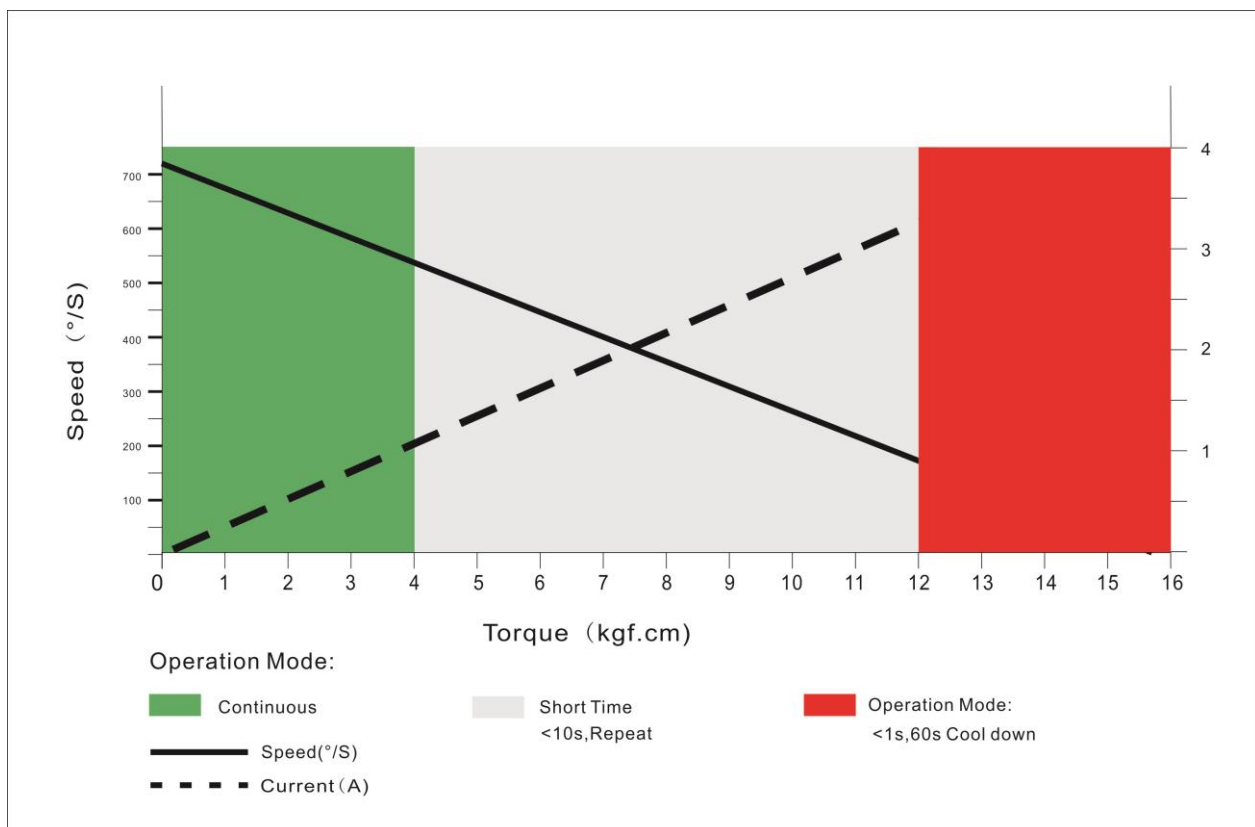

# PWM Command Signal

PWM	X15-1208
Signal Voltage	TTL-Level: HIGH:min.3.3V,max.5.0V TTL-Level: Low:min.0.0V,max.1.5V
Pulse Lengths	900-2100us
Pulse Lengths for Position $-50^{\circ}$ /center/ $+50^{\circ}$	1000us/1500us/2000us
Resolution	$\leq 2\mu\text{s}$

## Materials and protective features

Case Material	Aluminum Alloy
Motor Type	Coreless
Gear Material	Hardened Steel
Position Sensor	Potentionmeter
Connecting Cable	26AWG

## Dimensions

Case Dimensions	35.5*15*32.5mm
Weight	40g