



# Instructions & Safety Manual

---

## ***RUTHUNTER 400X TROPHY 410X***



*Read and follow all safety warnings and instructions in this manual.*

*Retain instructions and safety manual for future reference.*

# RutHunter 400X & Trophy 410X INSTRUCTION MANUAL

## **Congratulations!**

You have just purchased an Xpedition **RutHunter 400X** or **Trophy 410X** crossbow.

**Before assembling and operating your crossbow it is essential that you read the entirety of the Owner's manual.**

These crossbows have been engineered to be high-speed and lightweight. They have been designed, manufactured and tested for safety and performance when used in accordance with the instructional materials provided. Before you begin the assembly of your crossbow, please check and make sure the following components and accessories are fully included in the box.

1. Assembled Riser
2. Quick Detach Quiver
3. Quiver Mounting Hardware Pack
4. Assembly Hardware Pack
5. Rope Cocker
6. Silent Crank Cocking Device (Trophy 410X ONLY)
7. Lubewax
8. **RutHunter 400X:** Three (3) 20" Carbon Xit-20 bolts with clip on nocks & 100gr field points  
**Trophy 410X:** Six (6) 20" Carbon Xit-20 bolts with clip on nocks & 100gr field points
9. 4 x 32 Dual Illuminated Scope

## **RutHunter 400X**



## **Trophy 410X**



# ASSEMBLY GUIDE

**1**

Attach cable slide to cables as shown.

STEP 1-1

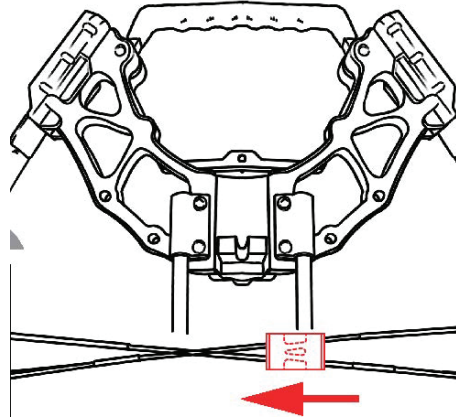

**2**

Lubricate and insert the cable slide under the rail.

STEP 2-1

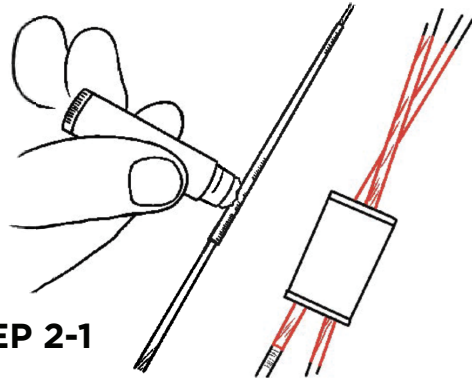

STEP 2-2

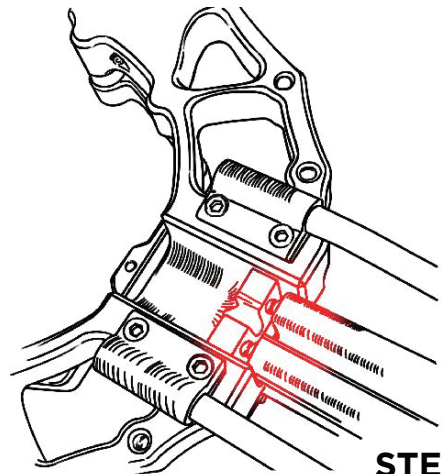
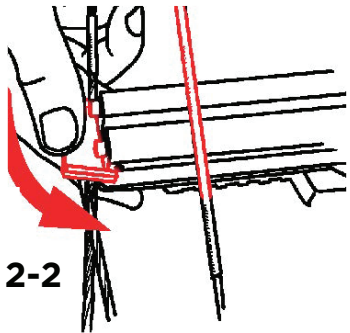

STEP 2-3

# CABLE SLIDE CLOSE UP

Front of bow

Back of bow

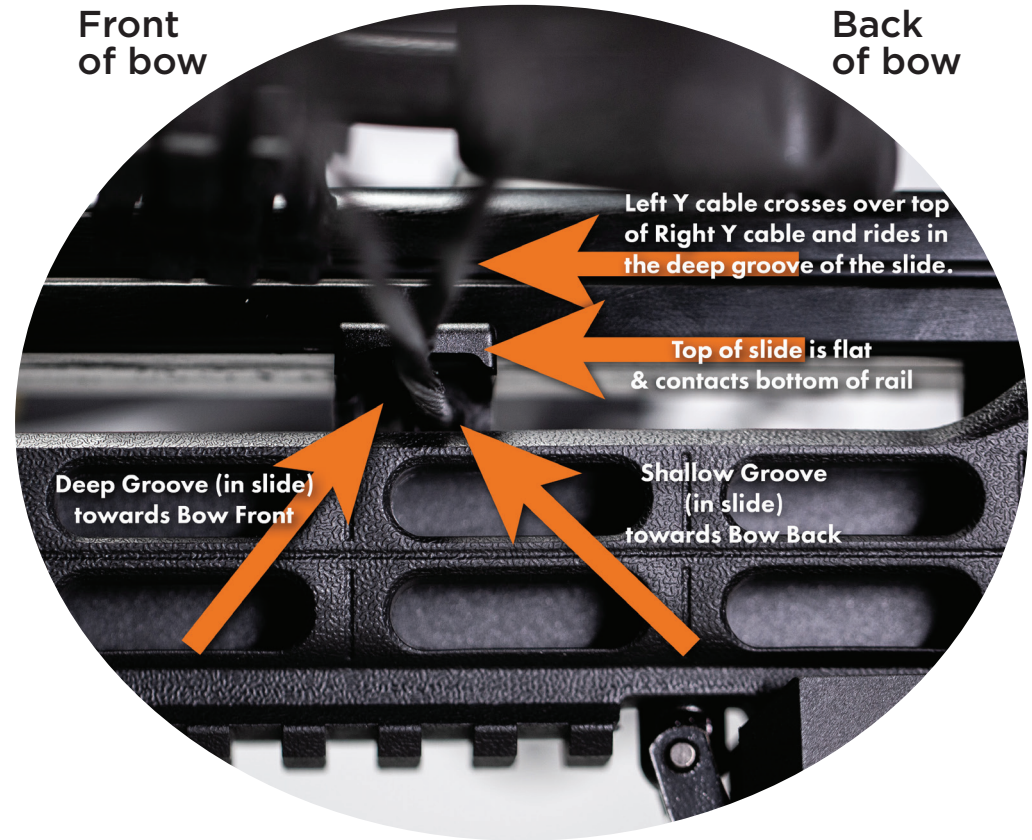

# 3

Attach the riser onto the rail by using the 33 mm bolts as shown after the cable slide and bowstring are properly positioned. Turn the riser over and tighten the 21 mm screw the back.

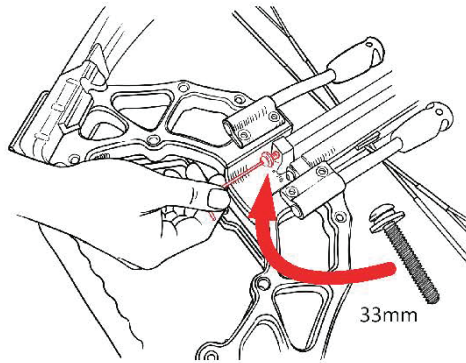

STEP 3-1

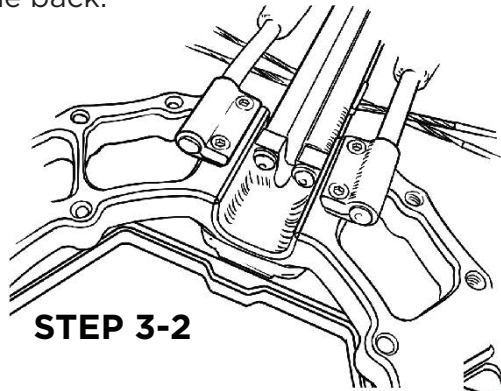

STEP 3-2

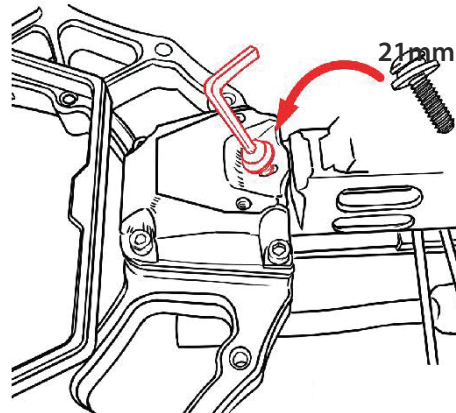

STEP 3-3

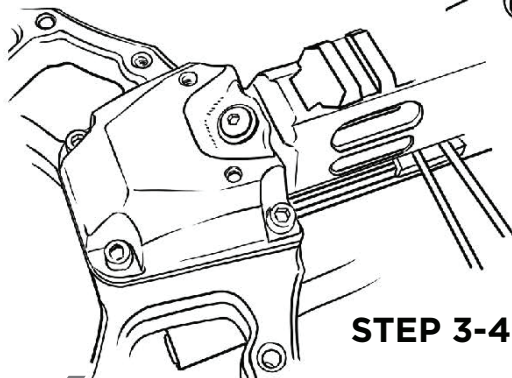

STEP 3-4

# 4

Slide the quiver mounting bracket onto the picatinny rail under the stock. Position the bracket by tightening the screws. Check your quiver mounting hardware pack for the components and hardware. Then attach the quiver onto the bracket.

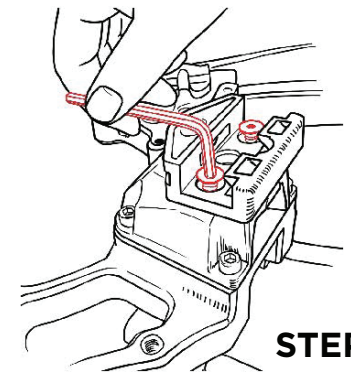
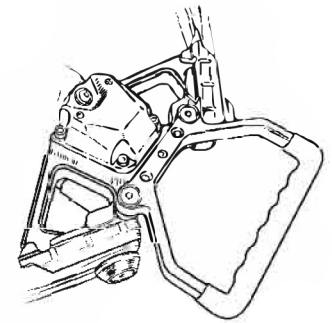
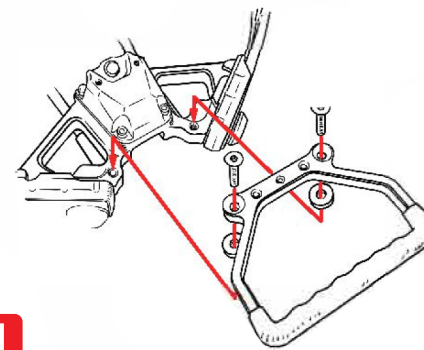

STEP 4-1

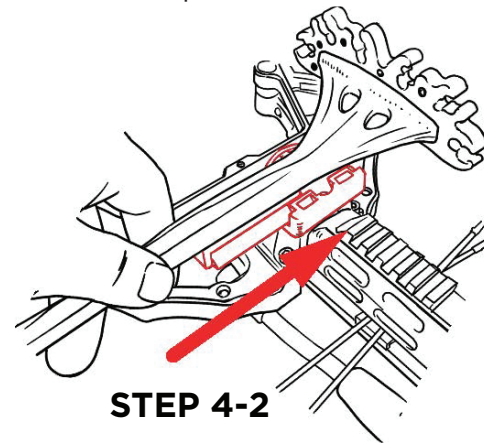

STEP 4-2

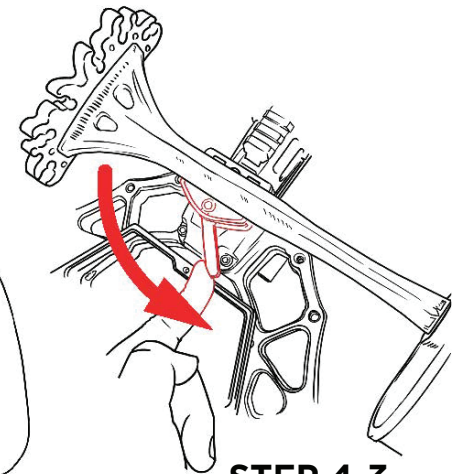

STEP 4-3

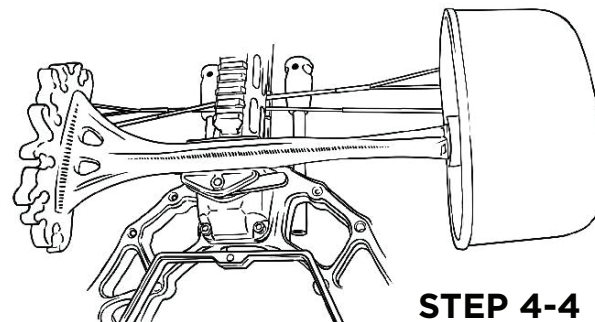

STEP 4-4



**5** The scope mount can be tilted to change the angle of the scope mount, front to back, to accommodate a variety of scopes. To change the angle, loosen the mounting screws on the scope mount and re-tighten them after the angle is set. Position your scope by moving it forward or backward until the proper eye relief is found. This is typically 3" to 4" from your eye to the eyepiece when you are holding the crossbow in a shooting position. Tighten the scope mount rings by the provided Allen wrench.

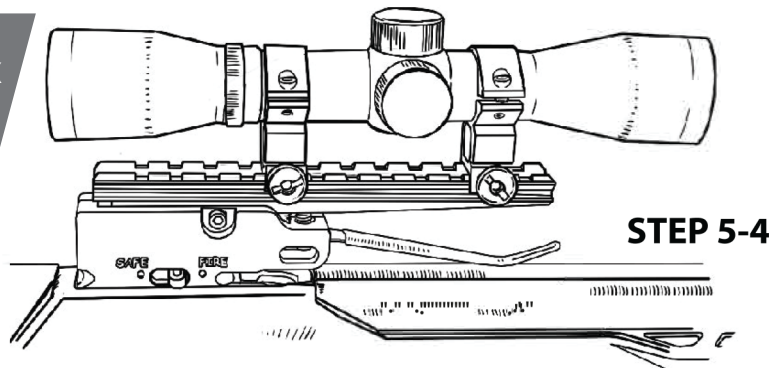
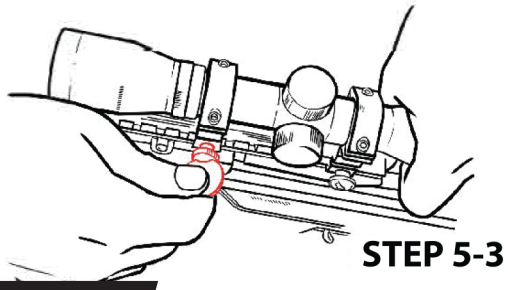
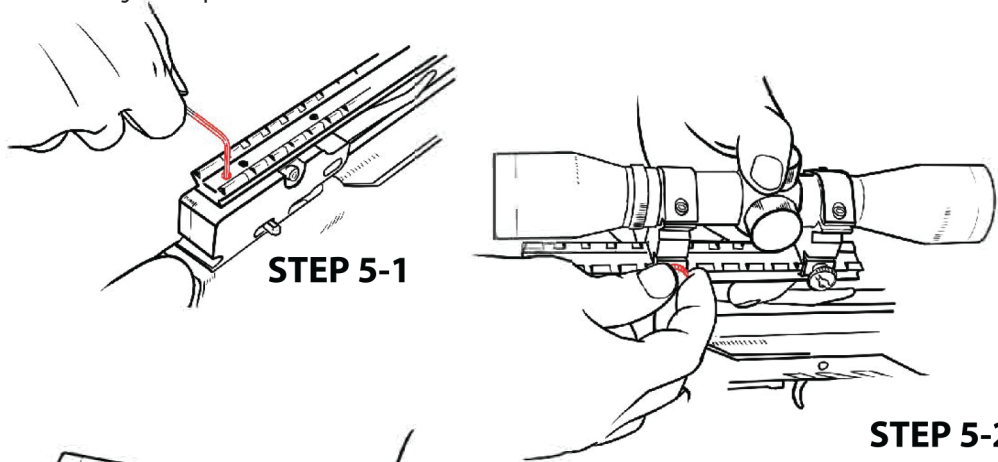

Watch the full  
**RutHunter 400X**  
**Trophy 410X**  
assembly here:



# CROSSBOW OPERATION

## 1 Using the rope cocker

Be sure to apply the lubewax to the string including the center serving, cables and the flight track before cocking.

Make sure the trigger's safety is in the "Fire" position before cocking your crossbow, otherwise the string latch will not engage or hold the bowstring. Place the trigger safety into the "Fire" position, and then place the center of the cocking rope in the rope groove. Set the foot stirrup on the ground with one foot in the stirrup and stock end resting against your thigh.

For the maximum pull force, place the cocker "hooks up", not hooks down, then pull with even force. Be sure the hooks must stay against the flight rail during cocking operation. Pull the rope until it locks into the trigger mechanism with an audible click and the safety is back in the "Safe" position. The crossbow is now cocked, ready for loading. Do not use your hand or the rope cocker to uncock the crossbow as it may cause serious injury to the user or damage to the crossbow.

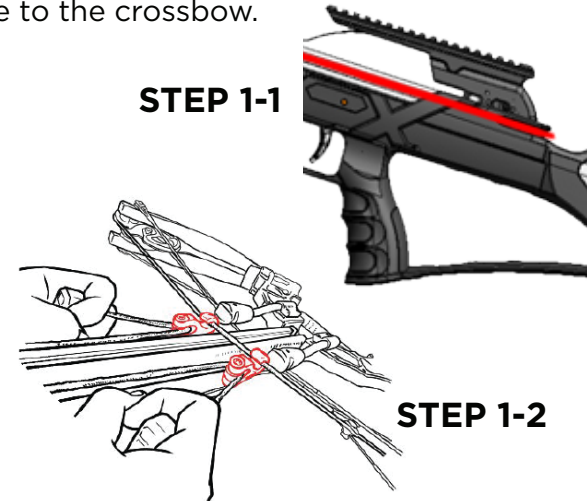

Watch how to  
use the **rope**  
**cocker** here:

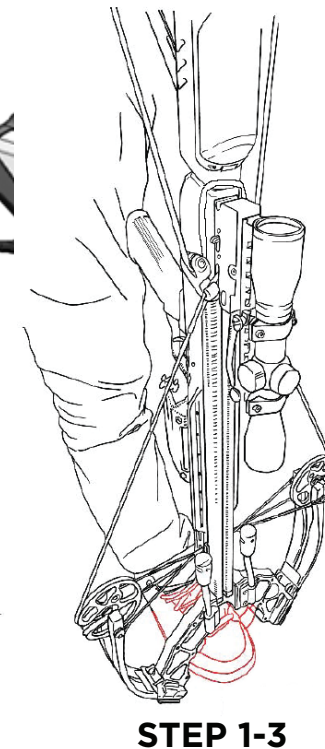
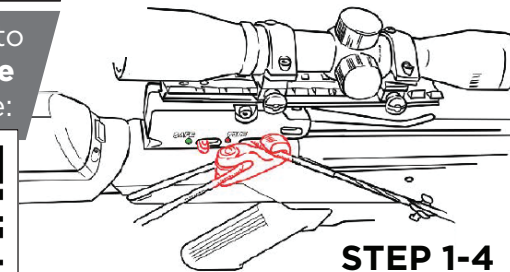

## 2 Loading the bolt

Place the bolt odd colored fletch in the flight groove and ensure that the clip-on nock is fully seated onto the string. Slide the bolt under the ball bearing and fully into the trigger mechanism against the string. Switch the trigger safety to "Fire" position again and you are now ready to aim and shoot.

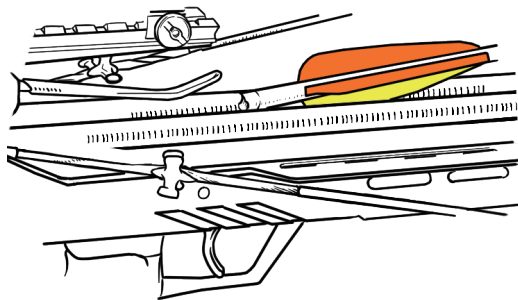

**Keep hands in front of string stops.**

## WARNING

**To avoid any injuries to yourself or others, or damage to your crossbow, the following safety instructions should be followed at all times.**

Never allow your fore-grip hand's fingers or thumb to move above the rails flight deck or into the bowstring or cables release path. Keep your hand and fingers in a safe position every time you shoot the crossbow.

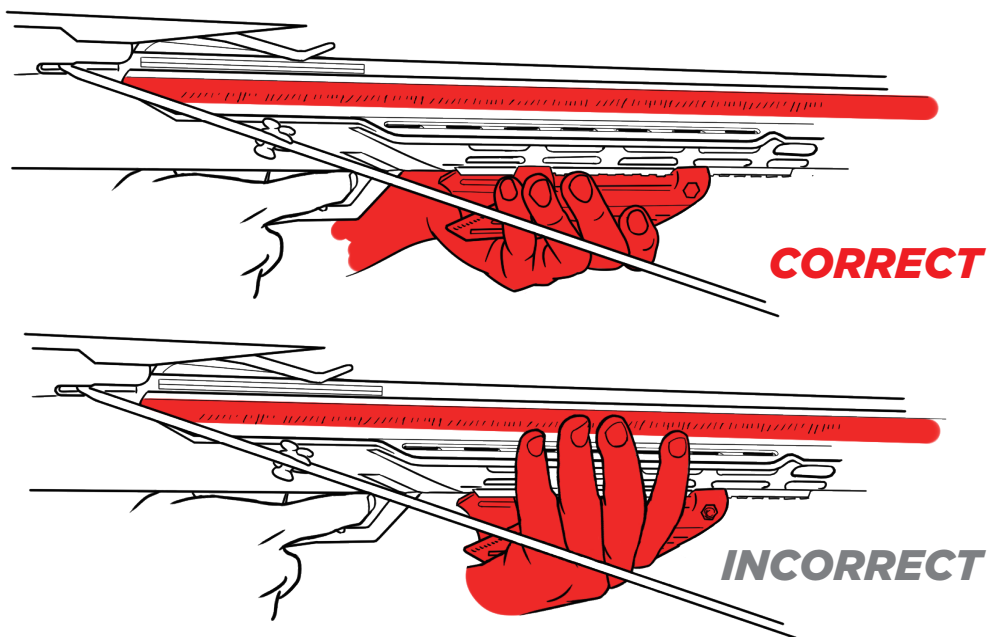

## SAFETY INSTRUCTIONS

- Always make sure the risers bolts/screws are securely tightened before using
- Never allow your fingers or thumb to move above the rail's flight deck and keep out of the path of cables and strings while holding the fore-grip
- Never dry-fire the crossbow. Shooting without a crossbow bolt is damaging to the crossbow. Dry firing will void the warranty and can result in damage to the limbs, string and cables possibly causing personal injury
- Always inspect the crossbow equipment for worn, loose, damaged or missing parts. Replace if any missing, fraying or damaged parts are observed or suspected
- Always point your crossbow in a safe direction and keep the crossbow out of the reach of children
- Do not remove or deactivate your crossbow's safety features or accessories, potentially rendering the crossbow dangerous to you or others - this will void warranty
- Replace strings and cables if visible signs of fraying or broken strands are evident
- Do not transport or store your crossbow while it is cocked or loaded
- Do not attempt to use your crossbow under the influence of alcohol, prescription or non-prescription drugs
- Always use suitable crossbow bolts/arrows. Bolts/arrows of improper stiffness or mass weight may damage the limb and cable assembly voiding the warranty and possibly causing personal injury
- When loading the bolt, keep hands in front of string stop

# MAINTENANCE & CARE

## STORAGE/TRANSPORTATION

- a. Always store your crossbow in a cool, dry place. Do not expose your crossbow to excessive heat. This includes leaving your crossbow in an automobile trunk for long periods of time.
- b. Never leave your crossbow cocked for long periods of time.
- c. When transporting your crossbow, abide by all fish and game laws pertaining to the area you reside in. Xpedition Archery recommends always transporting your crossbow in a crossbow case.

## STRINGS AND CABLES

- a. Apply String Wax/Rail lube every 5-10 shots. Rail lube can be “smeared” along the crossbow rail from the crossbow string to the trigger box. Rail lube reduces friction put onto the string and increases the longevity of the string.
- b. Apply String Wax/Rail Lube liberally to all non-served portions of the crossbow’s strings and cables.

# WARRANTY INFORMATION

Subject to the terms, conditions, and limitations outlined below. We guarantee 1 year warranty service to the original purchaser for our crossbows against defects in materials and workmanship that adversely affect the crossbows operation. The purchaser of the crossbow must register their crossbow within 30 days of purchase for the warranty to be valid. Warranties are non-transferrable. Crossbow strings, cables, cable slides, sleeve bushings, bearings, cosmetic appearance, and component parts and those which are subject to a variety of conditions in normal use and considered to be consumable parts will not be covered under warranty.

## LIMITED WARRANTY WILL BE VOID IF ANY OF THE FOLLOWING OCCUR:

- Damage is caused by dry-firing or by using underweight arrows/bolts
- The instructions in the owner’s manual are not followed
- The crossbow or any part or its parts of accessories are altered from their original state
- The crossbow has not been maintained properly
- Failure or damage was caused by improper calibration or by abnormal use

## WARRANTY CLAIMS

Contact Xpedition Archery Customer Service Department at 844-263-3665 or [warranty@xpeditionarchery.com](mailto:warranty@xpeditionarchery.com) for all warranty claims. Xpedition Archery will provide a return merchandise authorization (RMA) number before any product is returned. Product sent without an RMA will not be processed. Attached to the product, please provide your name, address, phone number, email, and a brief description of the issue with the product. Package and return the product with transportation charges pre-paid to Xpedition Archery. All accessories items must be removed from the crossbow prior to shipping. If determined warranty, Xpedition Archery will either fix or replace necessary items.







# ***XPEDITION***

A R C H E R Y

*Thank you for  
purchasing from  
Xpedition Crossbows!*

***Instructions & Safety Manual***

***RUTHUNTER 400X  
TROPHY 410X***