

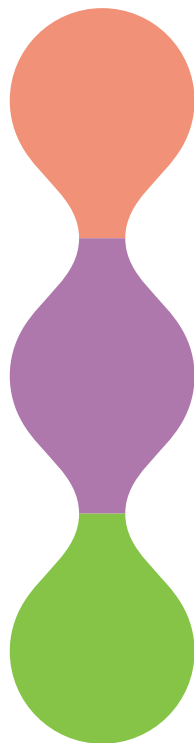

User Guide

IPS Inverter Series

IPS1202, IPS2402



Version 2.00
(English | Indonesian)

1 Package Contents

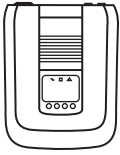

x 1

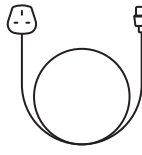

x 1

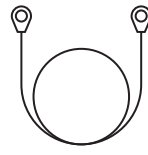

x 1

(Coupling cable, only for IPS2402)



x 2



x 1

Note:

1. The illustrations in this document may appear different from your model.
2. If any of above item is not packed in your package, please consult your seller immediately.

2 Overview

IPS1202/IPS2402

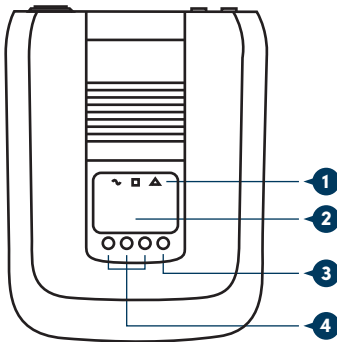

Front View

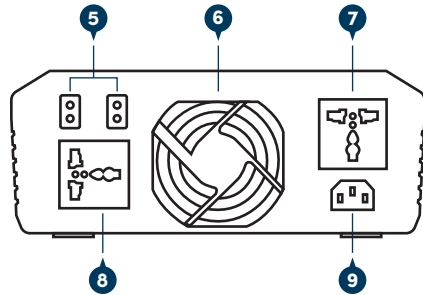

Rear View

Legend:

- | | | |
|------------------------------|--------------------------------------|----------------------------------|
| 1 LED indicator | 4 Settings function buttons | 7 AC output receptacles 1 |
| 2 LCD | 5 External battery connectors | 8 AC output receptacles 2 |
| 3 Power On/Off switch | 6 Cooling fan | 9 AC inlet |

3 Installation

Safety Clearance

The minimum clearance to the wall shall be larger than 30cm in order to ensure proper ventilation. In the event the ambient temperature is high, it's recommended to increase the distance of safety clearance to improve the heat dissipation.

Mounting Inverter on the wall

The inverter is designed to either be placed on horizontal surface or be mounted on the wall (as shown below). When mounting the inverter on the wall:

1. The wall shall be solid and strong enough to carry the inverter;
2. The location of installation shall allow the user to read the LCD easily;
3. Two screws shall be firstly fixed on the wall (distance as shown below) so that the inverter can be hung on the screws, recommended screw size is M4*50~65mm.
4. After mounting the inverter, make sure it's firmly mounted and won't easily fall off in the event of unexpected earthquake or vibration.

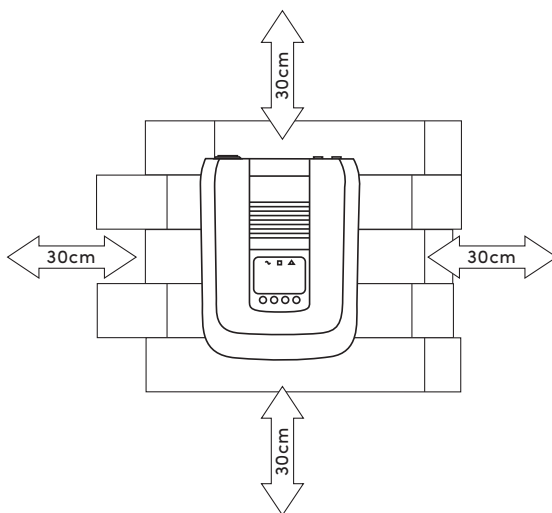

Batteries

Determine the size of battery

The inverter is designed with pre-set charging current and voltage. Given a fixed charging current, under-sized batteries may shorten the battery life while over-sized batteries may result in unreasonable recharging time. It is recommended that the batteries capacity shall be no less than 100AH.

3 Installation

Connect the battery cables

1. The gauge of battery cables shall be no less than 6 AWG with 105°C rating.
2. No matter how the batteries are connected (in series or in parallel), make sure the cables terminal voltage is consistent with the inverter's specification (12VDC for 1200VA model and 24VDC for 2200VA model).
3. It is recommended to cover the battery terminals during the connection.
4. Check the polarity of the cables before connecting to the inverter.
5. Connect the Inverter DC cables with battery terminals as shown below.

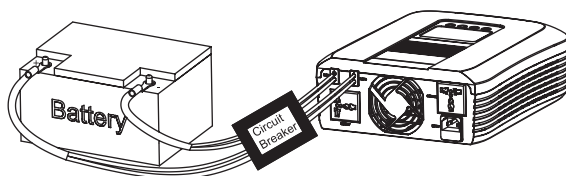

Connect with single battery

Make sure the battery voltage meets the inverter's specification (only for 12VDC model).

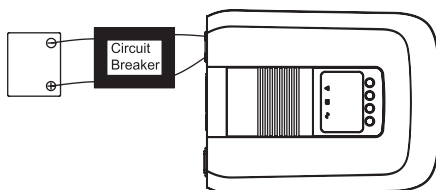

Connect with multiple batteries

 While connecting multiple batteries, use the same brand/type for all batteries. Do not mix the battery bank with different brand/type of batteries.

The user may connect the batteries in series in order to double the voltage connected to inverter. The diagram below illustrates how to connect two 12VDC batteries in series to make up 24VDC (only for 24VDC model).

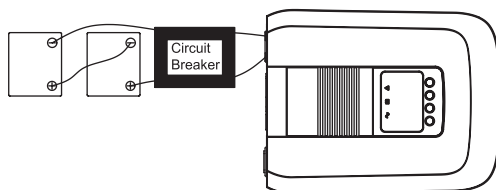

3 Installation

The user may connect the batteries in parallel in order to increase the total battery capacity without changing the battery voltage. The example below shows parallel connection of multiple 12VDC batteries. While the total capacity is times by the number of battery, the terminal voltage remains 12VDC (only for 12VDC model).

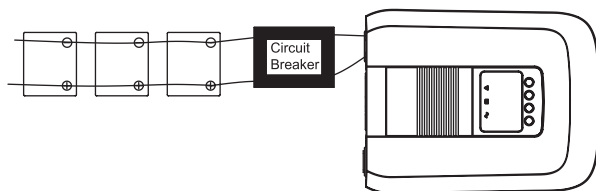

Connect AC input Cables and Loads

Connect the AC input cables and loads to the receptacles as shown below. Plug in the AC input power cord to the wall outlet. The unit will automatically charge the connected external battery even though the unit is off.

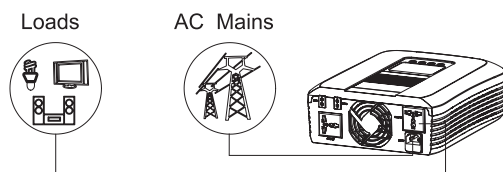

AC input voltage range selector

"NARROW" setting:

Configure LCD to "NARROW" when connected to loads that are more sensitive on voltage range. With this setting, the inverter is more sensitive to the voltage disturbance on the AC input and input voltage range is set at 170~280VAC while output voltage follows input voltage.

"WIDE" setting:

Configure LCD to "WIDE" when connected to loads that are less sensitive on voltage range (e. g. light bulb, fan, fluorescent tube, or TV). With this setting, the input voltage range is set at 90~280VAC while output voltage follows input voltage.

 Please note that the inverter's transfer time switching from Line Mode to Backup Mode gets longer as the input voltage gets low. Under the circumstance, connecting the inverter with loads (e.g. computer) which are sensitive to transfer time might result in power interruption.

4 Operations



After connecting batteries, AC input cables, and loads, the inverter is now ready for use.

Power On/Off

Once the inverter has been properly installed, press the power switch to turn on the unit. The unit will work automatically in line mode or inverter mode according to input utility power's status. To turn the unit off, press the power switch again.





LED Indicators

The operation mode of the inverter can be easily understood by LED indicators. Please refer to the table below for details.

LED Indicator		Information	
	Green	Line mode 1 (charge current >3A)	Green flashing every 2 seconds
		Line mode 1 (charge current ≤3A)	Green solid lighting
		Off charge mode	Green flashing in order of: 0.5s On→0.5s Off→0.5s On→3.5s Off
	Yellow	Battery mode	Yellow solid lighting
	Red	Overload	Red flashing every 0.5 seconds
		Fault	Red solid lighting

4 Operations





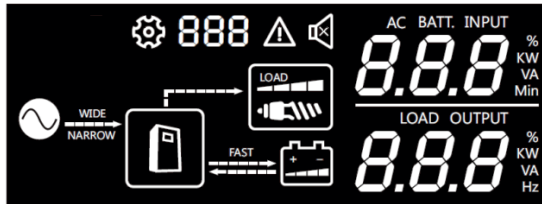

Function Keys

Function Keys	Description
	To power On/Off
	To enter the setting mode or exit setting mode
	To go to the next selection page
	To confirm the selection in setting mode





LCD Display

LCD displays the power flow and input/output readings in a visualized graphic design which allows the user to understand the operation status easily. The backlight of LCD remains on whenever the inverter is working (including Standby Charging Mode and Fault Mode).



Icon	Function
Input source information	
	Indicates the AC input
	Indicates input voltage
	Indicates the unit works in wide AC mode
	Indicates the unit works in narrow AC mode
Configuration Program and Fault Information	
	Indicates the setting programs
	Indicates the warning and fault codes

4 Operations

Icon	Function
Output information	
	Indicates output voltage, load in Watt
Battery Information	
	Indicates battery level by 0-24%, 25-49%, 50-74% and 75-100% in battery mode and charging status
Load Information	
	Indicates the load level by 0-24%, 25-49%, 50-74% and 75-100%
Mode operation information	
	Indicates the unit connects to the mains
Charging Information	
	Indicates the AC charger current is setting to Maximum

LCD Setting

1) Display menu

The LCD display content will be changed in turns by pressing  button. The selectable information is switched as below order:





AC input voltage, output voltage, battery voltage, output frequency, load percentage, load watt value. LCD will return to default LCD display after 30 seconds. Press  button to return to default LCD display immediately.

LCD Display Specification





Page Number	Upper Area Digital Display	Lower Area Digital Display
		
0	AC I/P Volt	O/P Volt
1	NA	O/P Volt
2	Battery Volt	O/P Volt
3	Battery Volt	O/P Freq
4	Battery Volt	Load O/P Percent
5	Battery Volt	Load O/P Watt





4 Operations

Operating Mode Description

Operating mode	LCD Default Display
Standby Charging Mode	Utility input bypass to output, and battery can be charged without switching on the unit. The  icon will flash every 0.5 seconds
	
Line Mode	Utility input bypass to output, and battery can be charged when switching on the unit
	
Backup Mode	The backup power to load comes only from battery
	

2) Setting menu

After pressing and hold  button for 3 seconds, the unit will enter setting mode. Press  button to select setting programs, and then, Press  button to confirm the selection. To exit the setting mode, press and hold the  button for 3 seconds. Setting mode will exit if no button is pressed within 30 seconds.

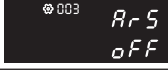
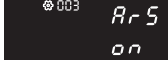
Setting Items	Icons	Description
AC input voltage range		Acceptable AC input voltage will be within 90-280VAC (default)
		Acceptable AC input voltage will be within 170-280VAC
Maximum AC charging current	1200VA model	
		Default utility charging current is 20A. Selectable options of 0/10/15/25A is available
	2200VA model	
		Default utility charging current is 15A. Selectable options of 0/5/10/20A is available
Auto restart when overload occurs		Auto restart is off in battery mode (default)
		Auto restart is on in battery mode. Note: Inverter will reset twice every 30 sec before entering into fault mode if overload is not released

4 Operations

Setting Items	Icons	Description
Battery shutdown voltage setting		<p>Setting range is from 10.0VDC to 11.0VDC for 12VDC model and 20.0VDC to 22.0VDC for 24VDC model. Low cut-off voltage will be fixed to setting value no matter what percentage of load is connected.</p> <p>Available options in 12VDC model : 10.0VDC (default)/10.2VDC/10.4VDC/10.6VDC/10.8VDC/11.0VDC.</p> <p>Available options in 24VDC model : 20.0VDC (default)/20.4VDC/20.8VDC/21.2VDC/21.6VDC/22.0VDC.</p>
Battery type	<p>AGM (default)</p>	<p>AC CHG (bulk/floating): 14.2VDC/14.2VDC (12VDC model default) 28.4VDC/28.4VDC (24VDC model default)</p>
	<p>Flooded</p>	
	<p>User defined</p>	<p>After this option is selected, items 06 & 07 will take effect</p>
Bulk charging (C.V voltage) voltage		<p>12VDC Model:14.2VDC (default) 24VDC Model:28.4VDC (default)</p> <p>If self-defined is selected in program 05, this program can be set up. Setting range is from 13.0VDC to 14.6VDC for 12VDC model and increment of each click is 0.1VDC. Setting range is from 26.0VDC to 29.2VDC for 24VDC model and increment of each click is 0.2VDC.</p>
Floating charging voltage		<p>12VDC Model:13.7VDC (default) 24VDC Model:27.4VDC (default)</p> <p>If self-defined is selected in program 05, this program can be set up. Setting range is from 13.0VDC to 14.6VDC for 12VDC model and increment of each click is 0.1VDC. Setting range is from 26.0VDC to 29.2VDC for 24VDC model and increment of each click is 0.2VDC.</p>
Recover manufactory setting	<p>Recover disable (default)</p> <p>Recover</p>	<p>Enable/Disable (default)</p>

4 Operations









Battery Charging Status 1.2 KVA

Status	Battery voltage				
		1	2	3	4
Floating	Bat=13.7VDC	Solid on	Solid on	Solid on	Solid on
CV	14.2>=Bat>=13.65VDC	Solid on	Solid on	Solid on	Flashing
CC	Bat>13.5VDC	Solid on	Solid on	Flashing	Flashing
	13.5>=Bat>13.0VDC	Solid on	Flashing	Flashing	Flashing
	Bat<=13.0VDC	Flashing	Flashing	Flashing	Flashing

Battery Charging Status 2.2 KVA

Status	Battery voltage				
		1	2	3	4
Floating	Bat=27.4VDC	Solid on	Solid on	Solid on	Solid on
CV	28.4>=Bat>=27.3VDC	Solid on	Solid on	Solid on	Flashing
CC	Bat>27VDC	Solid on	Solid on	Flashing	Flashing
	27>=Bat>26VDC	Solid on	Flashing	Flashing	Flashing
	Bat<=26VDC	Flashing	Flashing	Flashing	Flashing

Fault and warning code

Fault event or warning	Icon	Alarm
Battery low		Buzzing every 2 seconds
Overload warning		Buzzing every 0.5 seconds
High temperature		Buzzing every 0.5 seconds
Output volt high		Buzzing continuously
Output short		Buzzing continuously
Over charge		Buzzing continuously
Overload fault		Buzzing continuously
Fan fail		Buzzing continuously
Over temperature		Buzzing continuously

5 Troubleshooting

Problem	Possible Cause	Remedial Action
No LCD display	Battery voltage is low	Recharge the battery and check if the battery cables are well connected
	Battery is defective	Replace the batteries
	Power button is not pressed	Press and hold the power button
Mains are normal but works in backup mode	AC input is absent	Check the connection of AC input
Backup time is short	Overloading	Disconnect non critical loads
	Battery voltage is too low	Recharge battery for at least 8 hours
	Battery is bad	Replace good quality batteries
Alarm buzzer beeps continuously	Inverter entered into fault mode	Refer to the fault code to identify the fault and report to service representative for further assistance

6 Specification

Model		IPS1202	IPS2402
Capacity	VA/W	1200VA / 1000 W	2200 VA / 1800 W
Nominal Battery Voltage		12VDC	24VDC
Line Mode			
Input	Nominal Voltage	220-240VAC	
	Voltage Range	Wide mode: 90VAC-280VAC (default) Narrow mode: 170VAC-280VAC	
	Normal Frequency	40-70 Hz (auto sensing)	
Output	Voltage	Follow the Utility	
	Frequency	Follow the Utility	
	Output Waveform	Follow the Utility	
Efficiency		>95% (full R load, battery full charged)	
Transfer Time		15ms Typical, 40ms Max.	
Battery Mode			
Output	Voltage	230VAC (+10%/ - 18%)	
	Frequency	50/60 Hz (auto detection)	
	Output Waveform	Modified sine-wave	
Efficiency		>80%	
Overload Protection		1min@ >110%, 20 s@> 120%, 0s@>150%	
Protection		Discharge, over charged, over loading, short circuit, over temperature protection	
Battery Charger (Powered by AC)			
Charging Algorithm		3 stage charging	
AC Charge Current		20A (default), 0/10/15/25A (selectable)	15A (default), 0/5/10/20A (selectable)
Floating Charging Voltage		13.7VDC	27.4VDC
Over Charging Voltage		16VDC	32VDC
Physical			
Total # of Inverter Receptacles		(2) UN	
Dimension (W*H*D)		309.5*96*244 mm	
Weight		2.5kg	2.6kg
Warning Diagnostics			
Indicators		Inverter Status Display	
Audible Alarms		Low battery, Overload, Fault	
Environmental			
Operating Temperature		0°C to 55°C	
Operating Relative Humidity		5 to 95% Non condensing	
Management			
Auto-charger		Yes	
Auto-restart		Yes	

1 Isi Perangkat

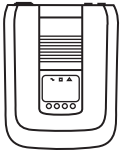

x 1

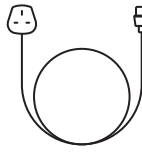

x 1

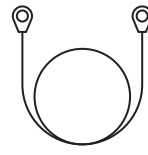

x 1

(Kabel kopling, hanya untuk IPS2402)



x 2



x 1

Nota:

1. Ilustrasi dalam dokumen ini mungkin tampak berbeda dari model Anda.
2. Jika salah satu item di atas tidak dikemas dalam paket Anda, harap segera berkonsultasi dengan penjual Anda.

2 Keterangan Gambar

IPS1202/IPS2402

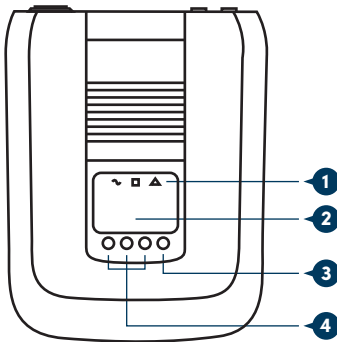

Tampak Hadapan

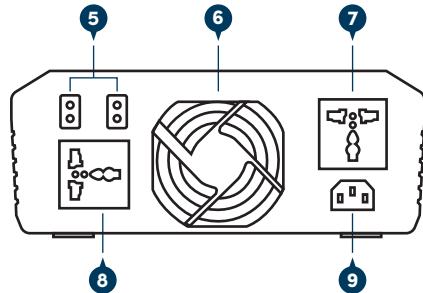

Tampak Belakang

Legend:

- | | | |
|----------------------|------------------------------|--------------------------|
| 1 Indikator LED | 4 Tombol fungsi pengaturan | 7 Stopkontak output AC 1 |
| 2 LCD | 5 Konektor baterai eksternal | 8 Stopkontak output AC 2 |
| 3 Sakelar Hidup/Mati | 6 Kipas pendingin | 9 Saluran masuk AC |

3 Instalasi

Izin Keselamatan

Jarak minimum ke dinding harus lebih besar dari 30cm untuk memastikan kesesuaian ventilasi. Jika suhu sekitar tinggi, disarankan untuk dinaikkan jarak aman untuk meningkatkan pembuangan panas.

Memasang Inverter di dinding

Inverter dirancang untuk ditempatkan pada permukaan horizontal atau dipasang pada dinding (seperti gambar di bawah). Saat memasang inverter di dinding:

1. Dinding harus kokoh dan cukup kuat untuk membawa inverter;
2. Lokasi pemasangan harus memungkinkan pengguna untuk membaca LCD dengan mudah;
3. Dua sekrup pertama-tama harus dipasang di dinding (jarak seperti yang ditunjukkan di bawah) sehingga inverter dapat digantung pada sekrup, ukuran sekrup yang disarankan adalah M4 * 50 ~ 65mm.
4. Setelah memasang inverter, pastikan sudah terpasang dengan kuat dan tidak mudah jatuh ke dalam kejadian gempa atau getaran yang tidak terduga.

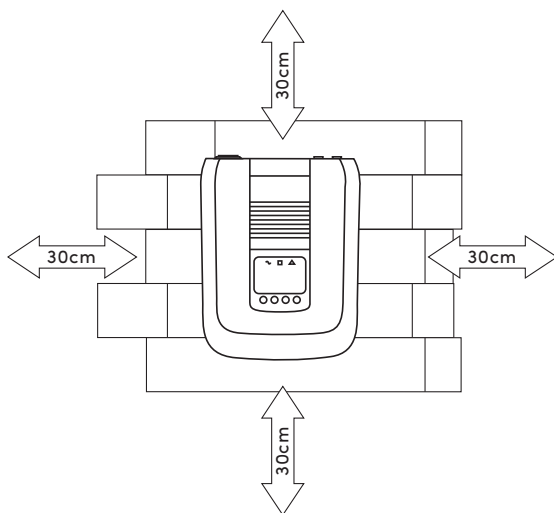

Baterai

Tentukan ukuran baterai

Inverter dirancang dengan arus dan tegangan pengisian yang telah diatur sebelumnya. Diberi pengisian tetap saat ini, baterai berukuran kecil dapat mempersingkat masa pakai baterai, sementara baterai berukuran besar mungkin mengakibatkan waktu pengisian ulang yang tidak wajar. Disarankan agar kapasitas baterai harus tidak kurang dari 100AH.

3 Instalasi

Hubungkan kabel baterai

1. Ukuran kabel baterai tidak boleh kurang dari 6 AWG dengan peringkat 105°C.
2. Tidak peduli bagaimana baterai terhubung (seri atau paralel), pastikan kabelnya tegangan terminal konsisten dengan spesifikasi inverter (12VDC untuk model 1200VA dan 24VDC untuk model 2200VA).
3. Disarankan untuk menutup terminal baterai selama penyambungan.
4. Periksa polaritas kabel sebelum menghubungkan ke inverter.
5. Hubungkan kabel DC Inverter dengan terminal baterai seperti yang ditunjukkan di bawah ini.

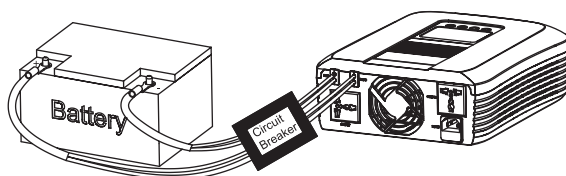

Terhubung dengan baterai tunggal

Pastikan tegangan baterai memenuhi spesifikasi inverter (Hanya untuk model 12VDC).

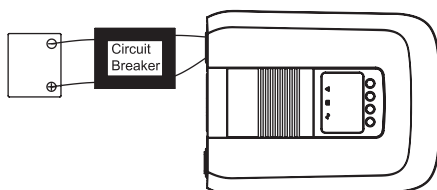

Hubungkan dengan beberapa baterai

 Saat menyambungkan beberapa baterai, gunakan merek/jenis yang sama untuk semua baterai. Tidak campur bank baterai dengan merek / jenis baterai yang berbeda.

Pengguna dapat menghubungkan baterai secara seri untuk menggandakan voltase yang terhubung inverter. Diagram di bawah menggambarkan bagaimana menghubungkan dua baterai 12VDC secara seri untuk membuat 24VDC (Hanya untuk model 24VDC)

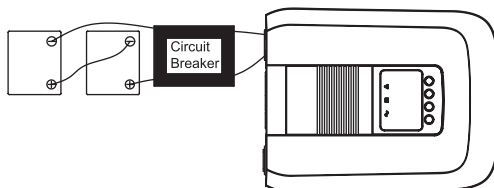

3 Instalasi

Pengguna dapat menghubungkan baterai secara paralel untuk meningkatkan kapasitas baterai total tanpa mengubah tegangan baterai. Contoh di bawah ini menunjukkan koneksi paralel dari beberapa baterai 12VDC. Sedangkan kapasitas total dikalikan dengan jumlah baterai terminal tegangan tetap 12VDC (Hanya untuk model 12VDC).

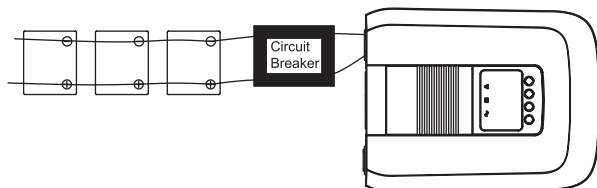

Hubungkan Kabel input AC dan Beban

Sambungkan kabel input AC dan beban ke stopkontak seperti yang ditunjukkan di bawah ini. Colokkan AC masukan kabel daya ke stopkontak. Unit akan secara otomatis mengisi daya eksternal yang terhubung baterai meskipun unit mati.

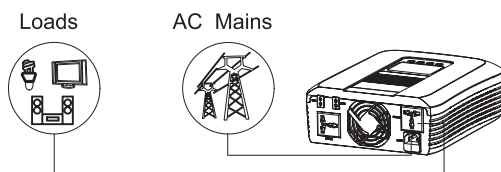

Pemilih rentang tegangan masukan AC

Pengaturan "NARROW":

Konfigurasi LCD ke "NARROW" saat terhubung ke beban yang lebih sensitif terhadap voltase jangkauan. Dengan pengaturan ini maka inverter lebih sensitif terhadap gangguan tegangan pada AC rentang tegangan input dan input diatur pada 170~280VAC sementara tegangan output mengikuti tegangan input.

Pengaturan "WIDE":

Konfigurasi LCD ke "WIDE" saat terhubung ke beban yang kurang sensitif terhadap voltase rentang (misalnya bola lampu, kipas angin, tabung neon, atau TV). Dengan pengaturan ini, tegangan input kisaran diatur pada 90 ~ 280VAC sedangkan tegangan output mengikuti tegangan input.



Harap dicatat bahwa waktu transfer inverter beralih dari Mode Saluran ke Mode Cadangan semakin lama seiring dengan semakin rendahnya tegangan input. Dalam keadaan ini, menghubungkan inverter dengan beban (misalnya komputer) yang sensitif terhadap waktu transfer dapat mengakibatkan gangguan listrik.

4 Operasi

Setelah menghubungkan baterai, kabel input AC, dan beban, inverter siap digunakan.

Hidupkan/Matikan

Setelah inverter terpasang dengan benar, tekan sakelar daya untuk menyalakan unit. Unit akan bekerja secara otomatis dalam mode garis atau mode inverter sesuai dengan utilitas input status kekuasaan. Untuk mematikan unit, tekan sakelar daya lagi.





Indikator LED

Mode operasi inverter dapat dengan mudah dipahami oleh indikator LED. Silakan lihat ke tabel di bawah ini untuk detailnya.

Indikator LED		Informasi	
	Hijau	Modus baris 1 (biaya saat ini > 3A)	Hijau berkedip setiap 2 detik
		Modus baris 1 (mengisi arus ≤ 3A)	Pencahayaan solid Hijau
		Mode tanpa biaya	Hijau berkedip sebagai siklus: 0.5s On → 0.5s Off → 0.5s On → 3.5 s Off
	Kuning	Modus baterai	Pencahayaan solid Kuning
	Merah	Kelebihan muatan	Merah berkedip setiap 0.5 detik
		Kesalahan	Pencahayaan merah solid

4 Operasi

Tombol Fungsi

Tombol Fungsi	Keterangan
	Untuk menghidupkan/mematikan
	Untuk masuk ke mode pengaturan atau keluar dari mode pengaturan
	Untuk pergi ke halaman pilihan berikutnya
	Untuk mengonfirmasi pilihan dalam mode pengaturan



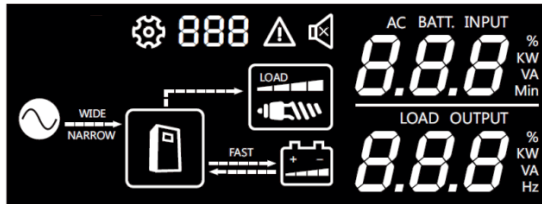

Layar LCD

LCD menampilkan aliran daya dan pembacaan input/output dalam desain grafis yang divisualisasikan yang memungkinkan pengguna untuk memahami status operasi dengan mudah. Lampu latar LCD tetap menyala setiap kali inverter bekerja (Termasuk Mode Pengisian Siaga dan Modus Kesalahan).



Ikon	Fungsi
Informasi sumber masukan	
AC	Menunjukkan input AC
8.8.8 v	Menunjukkan tegangan input
WIDE	Menunjukkan unit bekerja dalam mode AC lebar
NARROW	Menunjukkan unit bekerja dalam mode AC sempit
Program Konfigurasi dan Informasi Kesalahan	
⚙️ 888	Menunjukkan program pengaturan
888 ⚠️	Menunjukkan kode peringatan dan kesalahan

4 Operasi

Ikona	Fungsi
Informasi keluaran	
	Menunjukkan tegangan output, beban dalam Watt
Informasi Baterai	
	Menunjukkan level baterai menurut 0-24%, 25-49%, 50-74% dan 75-100% dalam mode baterai dan status pengisian daya
Memuat Informasi	
	Menunjukkan tingkat beban 0-24%, 25-49%, 50-74% and 75-100%
Informasi operasi mode	
	Menunjukkan unit terhubung ke listrik
Informasi Pengisian	
	Menunjukkan arus pengisi daya AC disetel ke Maksimum

Pengaturan LCD



1) Menampilkan menu

Konten tampilan LCD akan diubah secara bergiliran dengan menekan tombol . Yang dapat dipilih informasi dialihkan seperti urutan di bawah ini:

Tegangan input AC, tegangan output, tegangan baterai, frekuensi output, persentase beban, beban nilai watt. LCD akan kembali ke tampilan LCD default setelah 30 detik. Tekan tombol

 untuk kembali ke layar LCD standar segera.

Spesifikasi Layar LCD





Nomor halaman	Tampilan Digital Area Atas	Tampilan Digital Area Bawah
		
0	Tegangan AC I/P	Volt O/P
1	NA	Volt O/P
2	Volt Baterai	Volt O/P
3	Volt Baterai	O/P Freq
4	Volt Baterai	Memuat O/P Persen
5	Volt Baterai	Memuat O/P Watt





4 Operasi

Deskripsi Mode Operasi



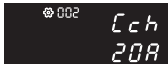

Modus operasi	Tampilan Standar LCD
Bersiap mengisi daya mode	Input utilitas memotong ke output, dan baterai dapat diisi tanpa menyalakan unit. Ikon  akan berkedip setiap 0.5 detik
Jalur modus	Input utilitas memotong ke output, dan baterai dapat diisi saat beralih pada unit
Modus cadangan	Daya cadangan untuk memuat hanya berasal dari baterai

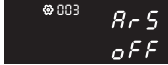
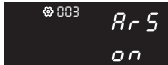
2) Menu pengaturan

Setelah menekan dan menahan tombol  selama 3 detik, unit akan memasuki mode pengaturan. Tekan  tombol untuk memilih program pengaturan, lalu tekan tombol  untuk konfirmasi pemilihan. Untuk keluar dari mode pengaturan, tekan dan tahan  tombol selama 3 detik. Mode pengaturan akan keluar jika tidak ada tombol yang ditekan dalam waktu 30 detik.

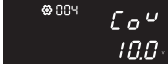
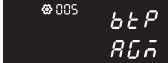
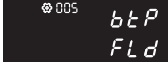
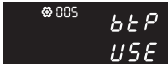
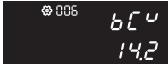
Mengatur Item	Ikon	Keterangan
Masukan AC rentang tegangan		Tegangan input AC yang dapat diterima akan diterima dalam 90-280VAC (standar)
		Tegangan input AC yang dapat diterima akan diterima dalam 170-280VAC
Maksimum Pengisian AC saat ini	Model 1200VA 	Arus pengisian utilitas default adalah 20A. Pilihan yang dapat dipilih dari 0/10/15/25A tersedia
	Model 2200VA 	Arus pengisian utilitas default adalah 15A. Pilihan yang dapat dipilih dari 0/5/10/20A tersedia
Mulai ulang otomatis ketika kelebihan beban terjadi		Restart otomatis mati dalam mode baterai (standar)
		Mulai ulang otomatis aktif dalam mode baterai. Catatan: Inverter akan diatur ulang dua kali setiap 30 detik sebelum masuk ke mode kesalahan jika beban berlebih tidak dilepaskan

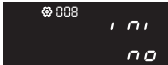
4 Operasi

Mengatur Item	Ikon	Keterangan
Baterai menutup pengaturan tegangan		Rentang pengaturan dari 10V hingga 11VDC untuk model 12VDC dan 20VDC ke 22VDC untuk model 24VDC. Cut-off rendah tegangan akan ditetapkan ke nilai pengaturan apa pun yang terjadi persentase beban terhubung. Pilihan yang tersedia dalam model 12VDC: 10.0VDC (standar)/10.2VDC/10.4VDC/10.6VDC/10.8VDC/11.0VDC Pilihan yang tersedia dalam model 24VDC: 20.0VDC (standar)/20.4VDC/20.8VDC/21.2VDC/22.0VDC
Jenis baterai	AGM (Standar)  Kebanjiran 	AC CHG (Massal/Mengambang): 14.2VDC/14.2VDC (standar Model 12VDC) 28.4VDC/28.4VDC (standar Model 24VDC)
	Ditetapkan pengguna 	Setelah opsi ini dipilih, item 06 & 07 akan diambil memengaruhi
Pengisian massal (Tegangan CV) voltase		12VDC Model: 14.2VDC (standar) 24VDC Model: 28.4VDC (standar) Jika ditentukan sendiri dipilih dalam program 05, ini program dapat diatur. Rentang pengaturan dari 13.0VDC ke 14.6VDC untuk model 12VDC dan peningkatan setiap klik adalah 0.1VDC. Rentang pengaturan dari 26.0VDC hingga 29.2VDC untuk 24VDC model dan peningkatan setiap klik adalah 0.2VDC.
Mengapung pengisian daya voltase		12VDC Model: 13.7VDC (standar) 24VDC Model: 27.4VDC (standar) Jika ditentukan sendiri dipilih dalam program 05, ini program dapat diatur. Rentang pengaturan dari 13.0VDC ke 14.6VDC untuk model 12VDC dan peningkatan setiap klik adalah 0.1VDC. Rentang pengaturan dari 26.0VDC hingga 29.2VDC untuk 24VDC model dan peningkatan setiap klik adalah 0.2VDC.
Pulih pabrik pengaturan	Pulihkan nonaktif (Standar)  Pulih 	Aktifkan/Nonaktifkan (standar)

4 Operasi









Status Pengisian Baterai 1.2 KVA

Status	Tegangan baterai				
		1	2	3	4
Apung	Bat=13.7VDC	Padat Aktif	Padat Aktif	Padat Aktif	Padat Aktif
CV	14.2>=Bat>=13.65VDC	Padat Aktif	Padat Aktif	Padat Aktif	Berkedip
CC	Bat>13.5VDC	Padat Aktif	Padat Aktif	Berkedip	Berkedip
	13.5>=Bat>13.0VDC	Padat Aktif	Berkedip	Berkedip	Berkedip
	Bat<=13.0VDC	Berkedip	Berkedip	Berkedip	Berkedip

Status Pengisian Baterai 2.2 KVA

Status	Tegangan baterai				
		1	2	3	4
Apung	Bat=27.4VDC	Padat Aktif	Padat Aktif	Padat Aktif	Padat Aktif
CV	28.4>=Bat>=27.3VDC	Padat Aktif	Padat Aktif	Padat Aktif	Berkedip
CC	Bat>27VDC	Padat Aktif	Padat Aktif	Berkedip	Berkedip
	27>=Bat>26VDC	Padat Aktif	Berkedip	Berkedip	Berkedip
	Bat<=26VDC	Berkedip	Berkedip	Berkedip	Berkedip

Kode kesalahan dan peringatan

Kejadian atau peringatan kesalahan	Ikon	Alarm
Baterai lemah		Berdengung setiap 2 detik
Peringatan kelebihan beban		Berdengung setiap 0.5 detik
Suhu tinggi		Berdengung setiap 0.5 detik
Keluaran volt tinggi		Berdengung terus menerus
Keluaran pendek		Berdengung terus menerus
Lebih dari biaya		Berdengung terus menerus
Kesalahan overload		Berdengung terus menerus
Kipas gagal		Berdengung terus menerus
Lebih dari suhu		Berdengung terus menerus

5 Penyelesaian masalah

Masalah	Kemungkinan penyebabnya	Tindakan perbaikan
Tidak ada layar LCD	Tegangan baterai rendah	Isi ulang baterai dan periksa apakah kabel baterai terhubung dengan baik
	Baterai rusak	Ganti baterainya
	Tombol daya tidak ditekan	Tekan dan tahan daya tombol
Listrik normal tetapi bekerja dalam cadangan mode	Masukan AC tidak ada	Periksa sambungan dari masukan AC
Waktu cadangan singkat	Kelebihan beban	Putuskan sambungan beban yang tidak kritis
	Tegangan baterai terlalu rendah	Isi ulang baterai setidaknya 8 jam
	Baterai buruk	Ganti baterai berkualitas baik
Bel alarm berbunyi bip terus menerus	Inverter dimasukkan ke dalam modus kesalahan	Lihat kode kesalahan ke mengidentifikasi kesalahan dan melaporkan untuk perwakilan layanan untuk bantuan lebih lanjut

6 Spesifikasi

Model		IPS1202	IPS2402
Kapasitas	VA/W	1200VA / 1000 W	2200 VA / 1800 W
Tegangan Baterai Nominal		12VDC	24VDC
Modus Garis			
Input	Tegangan Nominal	220-240VAC	
	Rentang Tegangan	Modus lebar: 90VAC-280VAC (standar) Modus sempit: 170VAC-280VAC	
	Frekuensi Biasa	40-70 Hz (penginderaan otomatis)	
Keluaran	Voltase	Ikuti Utilitas	
	Frekuensi	Ikuti Utilitas	
	Keluaran Waveform	Ikuti Utilitas	
Efisiensi		>95% (Beban R penuh, baterai terisi penuh)	
Waktu Transfer		15ms Typical, 40ms Max.	
Modus Baterai			
Output	Voltase	230VAC (+10%/ - 18%)	
	Frekuensi	50/60 Hz (deteksi otomatis)	
	Keluaran Waveform	Gelombang sinus yang dimodifikasi	
Efisiensi		>80%	
Perlindungan Kelebihan muatan		1min@ >110%, 20 s@> 120%, 0s@>150%	
Perlindungan		Discharge, over charge, over loading, sirkuit pendek, atas perlindungan suhu	
Pengisi Daya Baterai (Ditenagai oleh AC)			
Algoritma Pengisian		Pengisian daya 3 tahap	
Arus Pengisian AC		20A (standar), 0/10/15/25A (dapat dipilih)	15A (standar), 0/5/10/20A (dapat dipilih)
Tegangan Pengisian Mengambang		13.7VDC	27.4VDC
Lebih Pengisian Tegangan		16VDC	32VDC
Fisik			
Total # Wadah Inverter		(2) UN	
Dimensi (W*H*D)		309.5*96*244 mm	
Berat		2.5kg	2.6kg
Diagnostik Peringatan			
Indikator		Tampilan Status Inverter	
Alarm Terdengar		Baterai Rendah, Kelebihan Beban, Kesalahan	
Lingkungan			
Suhu Operasional		0°C to 55°C	
Kelembaban Relatif Pengoperasian		5 to 95% Non Kondensasi	
Pengelolaan			
Pengisi daya otomatis		Ya	
Mulai ulang otomatis		Ya	

Worldwide Customer Care Centers

INDONESIA Office

PT PROLiNK INTIDATA NUSANTARA

Walk-In : Jl. Cideng Barat No. 79, Jakarta Pusat 10150, Indonesia.

Telephone : +62 21 3483 1777

Sale Enquiries : sales.id@prolink2u.com

Technical Support : support.id@prolink2u.com

MALAYSIA Office

FIDA SYSTEMS (M) SDN BHD

Walk-In : 29 Jalan USJ 1/31, 47600 Subang Jaya, Selangor Darul Ehsan, Malaysia.

Telephone : +60 3 8024 9151

Sale Enquiries : sales.my@prolink2u.com

Technical Support : support.my@prolink2u.com

SINGAPORE Office

FIDA INTERNATIONAL (S) PTE LTD

Walk-In : Block 16 Kallang Place #06-02, Kallang Basin Industrial Estate, Singapore 339156.

Telephone : +65 6357 0668

Sale Enquiries : sales@prolink2u.com

Technical Support : support@prolink2u.com

Technical Support Hotline

INDONESIA : +62 21 3483 1717

MALAYSIA : +60 3 8023 9151

SINGAPORE : +65 6357 0666

Note: Closed on Saturdays, Sundays and local/regional Public Holidays.

Register online for your Product Warranty at www.prolink2u.com

Prolink is a registered trademark of Fida International (S) Pte Ltd. Other brands and product names are trademarks or registered trademarks of their respective holders. Product images are purely for illustrative purposes and may differ from the actual product. Specifications are subjected to changes without prior notice. Copyright © 2024 Fida International (S) Pte Ltd.

KETENTUAN GARANSI

Customer service: +62 855-1103-722

prolink

Kami mengucapkan terima kasih atas kepercayaan Anda memilih produk kami dan selaku Distributor di Indonesia, kami memberikan garansi Jasa Perbaikan dan Penggantian Suku Cadang dengan ketentuan sebagai berikut:

1. Jasa Perbaikan diberikan selama 12 (dua belas) bulan terhitung dari tanggal pembelian terhadap kerusakan-kerusakan berikut penggantian suku cadang.
2. Ongkos kirim dan kerusakan yang mungkin terjadi di dalam perjalanan menjadi tanggungan pemilik barang.
3. Garansi TIDAK BERLAKU atau menjadi BATAL:
 - Barang tersebut telah dibuka segelnya atau diperbaiki oleh pemilik / pihak ketiga.
 - Barang tersebut rusak akibat pengangkutan, jatuh atau kesalahan yang diakibatkan oleh pemakai.
 - Barang tersebut rusak akibat kebakaran, disambar petir atau bencana alam.
 - Nomor serinya telah berubah atau dihapus dan tidak sesuai dengan barang yang akan diperbaiki.
 - Kartu Garansi tidak ada tanda tangan dan cap penjual.
 - Kartu Garansi tidak sesuai dengan barang yang sebenarnya atau terdapat coretan-coretan dan hapusan pada Kartu Garansi.
4. Tunjukkan kartu Garansi ini saat barang hendak di service.
5. Untuk informasi mengenai penyimpanan dan pemeliharaan, silahkan lihat petunjuk pada buku manual.

Daftarkan secara online untuk jaminan produk Anda di www.prolink2u.com

*Biaya pengiriman ditanggung pembeli

DAFTAR LAYANAN PURNA JUAL :

1. PT. PROLINK INTIDATA NUSANTARA | JL. CIDENG BARAT NO. 79, JAKARTA PUSAT 10150 | Tel: 021-34831777
2. AT COMPUTER | RUKO KOMP SULTAN ADAM PERMAI, NO.13 BANJARMASIN | Tel: 0511-7404486
3. PT. PROSHOP TIMUR RAYA | JL. RAYA MANYAR 69E SURABAYA RT.004 RW.010, MENUR PUMPUNGAN SUKILOLO SURABAYA JAWA TIMUR 60286 | Tel: 031-59173511
4. PT. ANDARU PRIMA HARSA | JL. BRIGJEN KATAMSO NO 75-77 RT 044 RW 013, PRAWIRODIRJAN GONDOMANAN YOGYAKARTA 55655 | Tel: 0274-420277
5. DELTACOM | JL. MESJID RAYA NO.90K MAKASSAR | Tel: 0411-442806
6. PT. ARTHANAYA TEKNOLOGI | JL. TEUKU UMAR NO 200 KOMPLEKS PERTOKOAN AGUNG RAYA NO 12, DAUH PURI KAUH - DENPASAR BARAT-DENPASAR-BALI 80113 | Tel: 0361-2096382
7. METRO KOMPUTER | JL. GAJAH MADA NO.87 | Tel: 0561-741610
8. PT. DWIWIRA PUTRADINAMIKA | JL. SETIA BUDHI NO. 107A, PEKAN BARU | Tel: 0761-36486
9. PT. SQUARE GORONTALO | JL. S. PARMAN NO.38 BIAWAO, KOTA SELATAN KOTA GORONTALO | Tel: 082188007111
10. PT. INTI SANHO UTAMA TEKNOLOGI | JL. MENGGALA NO. 48 MEDAN | Tel: 061-7330800



prolink

Tempelkan
peranko
disini.

Kepada Yth.
Customer Service
PT. PROLINK INTIDATA NUSANTARA
Jl. Cideng Barat No. 79
Jakarta Pusat 10150 - Indonesia

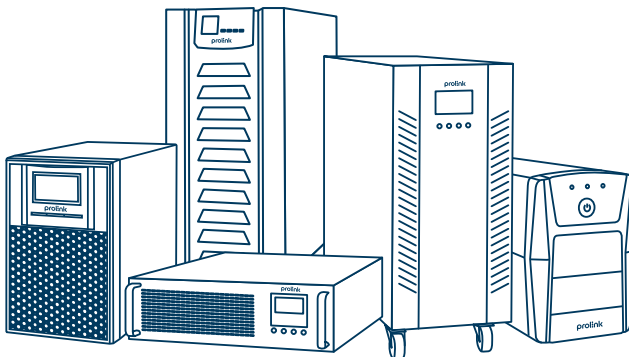

KARTU GARANSI
INDONESIA

Prolink Inverter/IPS

Model/Tipe: _____

KARTU GARANSI

Nama
Name :

Kapasitas: _____

Alamat
Address :

Nomor Seri: _____

Tgl. Pembelian: _____

Berlaku sampai: _____

Kota: _____ **Kode Pos:** _____

Toko
Kota :

Tel / Fax: _____

Pelanggan

PT. Prolink Intidata Nusantara

Cap Toko

Kartu Garansi harus diisi lengkap, kirimkan paling lambat 14 hari setelah Tgl. Pembelian

Alamat Pengiriman Address PT. PROLINK INTIDATA NUSANTARA
Jl. Cideng Barat No. 79 Jakarta Pusat 10150 - Indonesia

Telp. : (62-21) 34831777
Fax : (62-21) 34830788
Email : support.id@prolink2u.com



Prolink Inverter/IPS

Model/Tipe: _____

KARTU GARANSI

Nama
Name :

Kapasitas: _____

Alamat
Address :

Nomor Seri: _____

Tgl. Pembelian: _____

Berlaku sampai: _____

Kota: _____ **Kode Pos:** _____

Toko
Kota :

Tel / Fax: _____

Pelanggan

PT. Prolink Intidata Nusantara

Cap Toko

Kartu Garansi harus diisi lengkap, kirimkan paling lambat 14 hari setelah Tgl. Pembelian

Alamat Pengiriman Address PT. PROLINK INTIDATA NUSANTARA
Jl. Cideng Barat No. 79 Jakarta Pusat 10150 - Indonesia

Telp. : (62-21) 34831777
Fax : (62-21) 34830788
Email : support.id@prolink2u.com