



USER MANUAL

Model : Epower-99A



yes-per.com

Für die deutsche Beschreibung, können Sie von der Handbuchseite unserer Website herunterladen: yes-per.com/user-guide

Пожалуйста, перейдите на страницу руководства на нашем официальном сайте, чтобы загрузить русскоязычную версию руководства: yes-per.com/user-guide

Pour la version française du manuel d'utilisation, veuillez le télécharger à partir de la page du manuel d'utilisation de notre Site Officiel : yes-per.com/user-guide

日本語取扱説明書については、公式サイト取扱説明書ページからダウンロードしてください: yes-per.com/user-guide



USER MANUAL

Thank you for choosing the Yesper Monster Start! Always follow basic safety precautions when using electrical appliances. Read all instructions carefully, Please keep this instruction manual for easy reference.

A. PRODUCT LAYOUT:

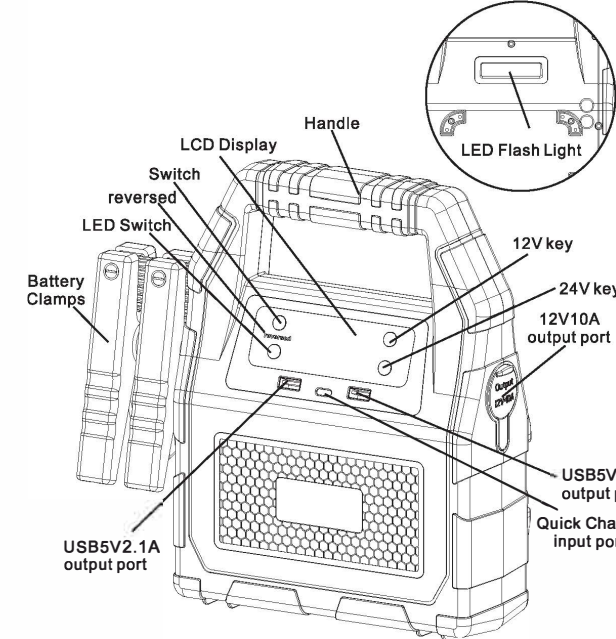

B. OPERATION GUIDANCE

LCD Display Description:

1. The power display: Press switch button ,display "BATTERY", also shows the host power. XX%, indicates that the battery has a XX% of the electricity; 100%, indicates that full power; display "BATTERY LOW RECHARGE", indicates that Monster Start power is low, please charge.

2. The products charge:

Monster Start connected to home or car charger charge, displays "CHARGING", and displays the current battery power.

3. LED lighting display:

Pressing Monster Start host light switch can turn on and off different lighting modes, as follows: lighting modes: Show LIGHT; Strobe Mode: Displays FLASH; SOS mode: the SOS closed.

4.USB output display:

5V2.1A /1AUSB output: When 5V2.1A/1A USB output port connected to the USB cable and press the power button , the display shows: "USB ON", then it can be used to charge for give mobile phones,tablet computers and other digital products.

5. Output short-circuit show: It shows that car battery are short-circuit of output when "WARNING SHORT CIRCUIT CHECK ALL CONNECTIONS" appears in screen. At this time, the start is prohibited. And remove the jumper cable, and keep pressing power button 3S to deal with question. If question not to be dealt with, please call professionals to check.

6.12V/ 24V output display:

1. Press 12V key, displays "12V JUMP START READY";
2. Press 24V key, displays"24V JUMP START READY".

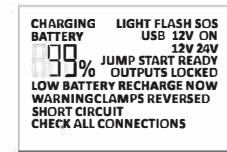

Monster Start Charging Instruction:

1. Connect the USB cable with the home adaptor and then plug the home adaptor into the universal socket.
2. Connect the Type-C connector to the Monster Start host.

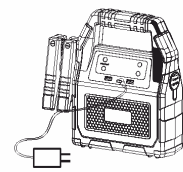

Jump Start Vehicle Instruction:

1. Make sure the numbers LCD Display is not less than 20%.
2. Connect the BALCK clamp to the vehicle's battery positive (+) terminal and connect the BALCK clamp to the vehicle's battery negative (-) terminal.If the battery clamp of the product is connected to the battery reversely, the REVERSED light will be on and beep. At this time, it should be prohibited to start, unplugging the battery clamp, and reconnect the battery clamp correctly.
3. When jump start 12V car,host displays"12V JUMP START READY", when jump start 24V car,host displays"24V JUMP START READY", 4.Start the vehicle.
5. When the vehicle is started, remove the jumper cable from Jump Starter and disconnect RED and BALCK clamps from the vehicle battery. Leave the vehicle's engine running.

Error operation prompt:

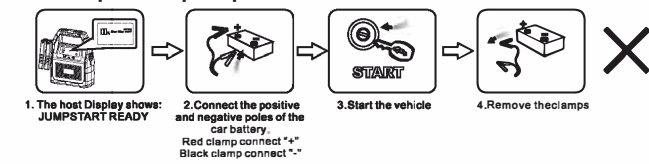

Q. How many times can this appliance to jump start the vehicle?
A. Normally it can jump start 12V vehicle approx. 40 times, can jump start 24V vehicle approx. 30 times.

Q. How long time to full charge the Monster Start?
A. Approx. 10 hours through the Quick Charge input port.

Q. How many times can this appliance charge for my cell phone?
A. Depend on the battery capacity of your cell phone. Take iPhone6 as an example, can full charging 11 times.

Q. How about the lifetime of this appliance?
A. About 3-5 years.

Q. How long does the battery last after fully charged?
A. 6-12 months, however, we suggest you recharge it every 3 months.

F. TROUBLE SHOOTING:

Finding	Cause	Remedies
No response when pressing the switch button.	Low voltage protection of Jump Starter is started.	Plug the adapter into the Quick Charge input port to activate.

G. TOXIC AND HARMFUL SUBSTANCES:

15/20/40.					
Pb	Hg	Cd	Cr(VI)	PBB	PBDE
0	0	0	0	0	0

D: Indicate all homogeneous materials' hazardous substances content are below the MCV limit specified in the Standard 2002/95/EC(RoHS).

H. WARNING:

1. Read the instruction manual carefully before using this unit.
2. Jump for 12V/24V vehicles, it would be hazard if for other jumping.
3. DO NOT use this unit if any cable clamp or cord is damaged.
4. DO NOT use in place of a vehicle battery.
5. Never remain the unit on car battery after cranking the car success.
6. Make sure to check all the battery connections are CLEAN before Jump Starting! Make sure the battery clamps are well connected! If the battery terminals on the vehicle are dirty or corroded, the power of the unit will be lessened.
7. Do NOT Jump Start more than 3 times in a row. It could damage the unit by overheating. When starting up multiple times, each start-up interval is two minutes.
8. Remove the product from the vehicle battery within 30 seconds of Jump Starting. If not, it could lead to damage.
9. Do NOT connect the two clamps together.
10. Do NOT use by young or infirm persons without supervision.
11. Do NOT use as a toy.
12. Do NOT allow the product to become wet.
13. Do NOT immerse the product in water.
14. Do NOT operate the product in explosive atmospheres, such as in the presence of flammable liquids, gases or dust.
15. Do NOT modify or disassemble Monster Start. Only a repair technician may repair this unit.
16. Do NOT expose product to extreme heat or fire.
17. Make sure someone should be within range of your voice or close enough to come to your aid when working with batteries.
18. Remove personal metal items like rings, bracelets, necklaces, etc. When using the products.
19. Do NOT drop unit. If unit receives a sharp blow or is otherwise damaged in any way have it checked by a qualified battery technician.
20. Do NOT store in locations where the temperature may exceed 60°C

21. Charge only at ambient temperature between 0°C and 45°C.
22. Charge only using the charger provided with this unit or the same standard with the host input port.
23. Do NOT use the unit to jump start a vehicle while charging the internal battery.
24. If this unit is leaking liquid dispose of at proper recycle facility immediately.
25. Under extreme conditions, battery leakage can occur. If a liquid is noticed coming from product do not handle with bare hands. In case of skin contact wash with soap and water immediately. If liquid comes in contact with eyes rinse eyes with cold running water for at least 10 minutes and get medical attention immediately.
26. Product contains lithium based battery, at end of product life dispose of product according to local regulation.
27. After jump start the car, don't charge this unit immediately.
28. Don't use the jumper cable to charge other equipments.

I. WARRANTY INFORMATION:

1. We offer a limited warranty for this product against any defects in material and workmanship for a period of 6 months from the date of purchase by the end user/consumer. The conditions of the warranty are as follows:
 2. The warranty is only valid upon presentation of the original receipt (from dealer/retailer) by the original purchaser with the product to be repaired or replaced.
 3. The warranty is void if the serial number, date of purchase and label has been removed.
 4. The warranty does not cover damage or product failure resulting from normal wear and tear, physical abuse, improper installation, misuse, modification or repairs by unauthorized third parties.
 5. We do not assume responsibility for any loss or damage incurred during shipment or as a result of a force majeure.
 6. We are not liable for any incidental or consequential damages arising from the use or misuse of this product.
 7. All warranty claims are limited to repair or replacement of the defective product and at the sole discretion of us.
 8. If we repair or replace the product, the product will be covered for the remaining time of the original warranty period. Repair or replacement may involve the use of reconditioned units which are equivalent in function. Replaced part or product becomes the property of us.
 9. Consumable components such as batteries are not covered by the warranty.



J. WARRANTY INFORMATION:

- 12+6 Months Online After-Sales Service
- Within 12 months, we will provide timely and effective online after-sales service after your purchase. If you register on our official store: yes-per.com and become our member customer, you will get extra 6 months service, total 18 months.
-
- Scan to be our member for extending more 6 months warranty
- 30 Days Money Back Guarantee
- Within the first 30 days after your purchase, you can apply return for it through YOUR SELLER when you have any issue.
- 30 Days to 12 Months (18 Months for Member Customers)
- We will replace the defective unit due to manufacturing issues with a new one within 12 months; if you are our member customer, within 18 months.

Attention

- Do Not Submerge In Water
- Do Not Disassemble
- Do Not Drop
- Avoid Extreme Temperatures
- Do Not Place Near or Into Fire



Customer Service

- 12+6 Months Limited Warranty Service
- Lifetime Technical Service
- Feel Free to Contact Us cs@yes-per.com
- For FAQ and More Information yes-per.com



Thank You
for Choosing



Made in China

128g铜版 双面单黑印刷 风琴折

93*130mm