

YESPER
Don't Say Desperate, Say Yesper!

User Manual JUMP STARTER



Model: Armor
/Armor(Heating)



YESPER

Thank you for choosing the Yesper Armor jump starter. To ensure a good user experience, personal safety, and property security, please read all of the instructions carefully before using this product, please keep this manual for reference.

Charge It First !
Before reading through the manual, you can begin to charge up your Yesper Armor jump starter with the car charger provided.

Warning
This host is with 12V batteries. It may be dangerous if it is used with other types of batteries. Read and understand the safety information before using the portable power station. Failure to follow the safety information may cause damage to the jump starter, and may also result in electric shock, explosions, fire, property damage, and personal injury.

1

YESPER

Product Parts and Functions Description

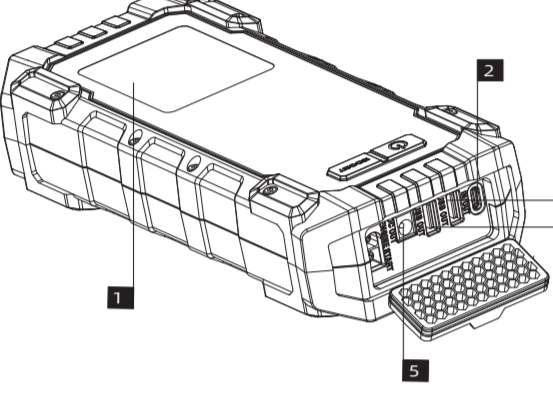

1. Display Screen
2. USB-C In/Out Port (PD100W Max)
3. USB1 Out Port (QC3.0, 5V/9V/12V)
4. USB2 Out Port (5V/2.4A)
5. DC Out Port (15V/10A, Max 150W)

2

YESPER

Product Parts and Functions Description

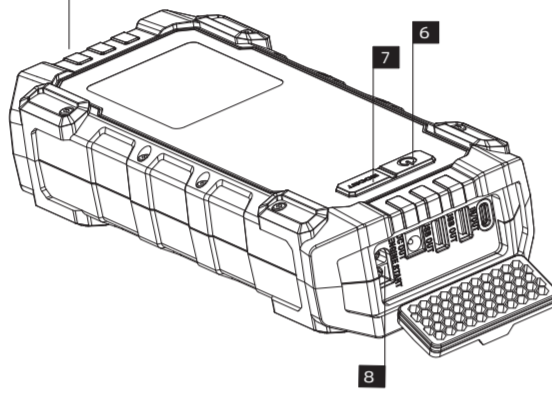

6. **Power Button:** Press 1-2s to power on the jump starter. Press about 10s to force shutdown.
7. **BOOST Button:** Press 1-2s to force output, and **READY** will be displayed on the screen.
8. **12V Battery Clamps Output:** DO NOT press the **BOOST** button before connecting the clamps to the vehicle battery correctly.
9. **LED Light:** Turn on the unit first by pressing the power button for 1-2s, then press the power button 1-2s again to turn on the LED light.

3

YESPER

Display Screen Instructions

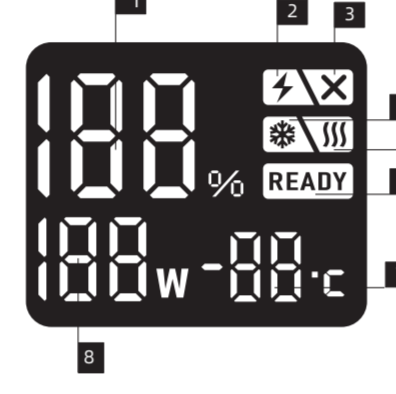

1. **Battery Power Percentage:** Battery percentage of charge/standby/discharge
2. **Low Current Mode:** Support charging for the devices that need light charging current like headphone, smart watch, etc. Press **POWER** and **BOOST** button simultaneously for 2-3s to turn on this mode.
3. **“+” and “-” Poles of Battery Clips Reversed**
4. **Battery Low Temperature Reminder**
5. **Battery Pre-heating:** Armor(Heating)
6. **Ready to Start the Vehicle**
7. **Pre-heating Temperature Display:** Armor(Heating)
8. **Charge Power/Discharge Power**

4

YESPER

USB-C IN (SC100W Car Charger)	12V BATTERY CLAMP OUT	USB-A/C OUT	DC OUT
---	------------------------------	--------------------	---------------

Support PD100W Max Speed Charging
This unit can be charged with car charger provided or quick speed wall charger (Quick Speed Wall Charger not included). Only via the SC100W car charger can this unit achieve the 100W max input function. PD65W USB-C quick speed wall charger need to purchase separately.

5

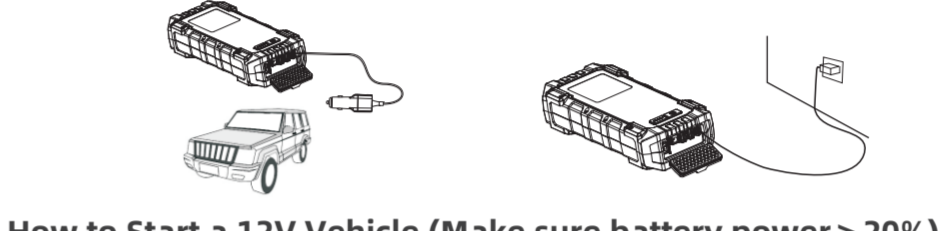

YESPER



How to Start a 12V Vehicle (Make sure battery power > 20%)

Note: Do not press the **BOOST** button before connecting the vehicle battery correctly.

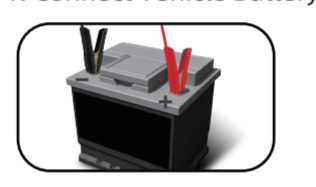
1. Connect Vehicle Battery
2. **READY (Solid)**
3. Start Vehicle Engine

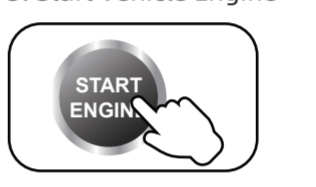
6

YESPER

Error Message/ Cause/ Solution

Error Message	Cause	Error Solution
X + Beeping	Reverse connection	Please correct the connection between jump clamps and battery terminals
READY (blinks) +Beeping	Vehicle battery dead	Press “BOOST” for 2-3s when “READY” icon is solid, start the vehicle within 30s.
“1” + Beeping	The temp of jump starter is too low or high.	Restore the temp of jump starter to 32F-113F.
“2” + Beeping	Overcurrent protection	Stop starting your vehicle, protection mode will disappear after 30s.
“3” + Beeping	Non-stop starts vehicles more than 4 times within 10mins, it entered safe mode.	Stop starting your vehicle, safe mode will disappear after 10mins.

If the problem persists, stop using the jump starter and contact our service team directly at cs@yes-per.com, we will do our best to solve the problem within 24 hours.

7

YESPER

15V/10A DC Output (12-16.8V,150W Max)

Connect the 12V devices that need to be powered by cigarette lighter socket (the **Cigarette Lighter Socket Adapter** is included).

How to Turn On/Off the LED Flashlight

Power on, then press power button for 1-2s to turn on the LED light. There are 3 modes of LED light (Normal, Strobe, SOS, Off) if you press lightly.

IP65 Water Resistant
It doesn't matter when this unit touched with small splashes, you just need to wipe it off. It can prevent splash water in your daily life, but it is not allowed to be immersed in water.

Pre-heating Technology (Unique features of Armor(Heating))
Armor can be used in an environment of -40°C and reach the starting temperature within 100 seconds after connecting the vehicle battery. The jump starter will automatically turn on the pre-heating function after connecting the vehicle battery or pressing **BOOST** button 1-2s in extremely cold environment.

8

YESPER

Technical Specification

Model	Armor/Armor(Heating)
Size	238*105*53mm
Battery Capacity	74Wh
Output USB-C	PD100W Max (5V/3A, 9V/3A, 12V/3A, 15V/3A, 20V/5A)
Output USB1	QC3.0 18W Max (5V/3A, 9V/2A, 12V/1.5A)
Output USB2	5V/2.4A
Output DC	15V/10A
Jump Start output	12V
Input	PD100W Max
Full charging time	0.75 hours
Starting current	600A
Peak current	3000A
Operating temperature	-20°C - 60°C
Discharge temperature	0°C - 45°C

9

YESPER

Toxic and Harmful Substances

Composition and amount of toxic or harmful substance in this product

Pb	Hg	Cd	Cr(VI)	PBB	PBDE
0	0	0	0	0	0

0: Indicate that the content of harmful substances in all homogeneous materials is all lower than the prescribed limit of MCV (the standard 2002/95/EC/RoHS)

FAQ

Q1: What is the operating temperature of this unit and how to store it?
A: This unit is lithium polymer battery, operating temp is -20-60°C/ -4-140°F. If the ambient temperature is higher than 60°C/140°F, the internal construction of the battery cells may be damaged, it may swell and become unsafe. So don't store the device in vehicle which parked in hot weather for long periods of time.

10

YESPER

Q2: How to start a vehicle with this unit?
A: Please refer to the instructions about “How to Start a 12V Vehicle”.

Q3: How do you know if this unit is connected to the vehicle correctly?
A: With the battery clamps connected to the vehicle battery, if the **READY(Solid)** appears on the screen, it means clamps connected correctly, while if **X** appears on the screen, which means it's connected reversely.

Q4: What should I do if this unit can't start a vehicle?
A: Recharge this unit fully, and try to press the “**BOOST**” button after connecting the vehicle battery correctly, **READY(Solid)** will appear on the screen, then start the vehicle within 30s. If it still does not work, contact us at: cs@yes-per.com (Attach your order ID).

Q5: What should I do if this unit can't charge up?
A: Charge it with a USB-C cable and wall charger for a full overnight period. If it still does not work, contact us at: cs@yes-per.com (Attach your order ID).

11

YESPER

Q6: What should I do if this unit can't charge other devices?
A: Try to charge the device with another charging cable, if it works, which means the charging cable we provided is defective, we will provide you a new one; if it still does not work, please email us at: cs@yes-per.com (Attach your order ID).

Q7: How to turn off this unit ?
A: This unit will be turned off automatically in 30s when it's not used. Or you can press **POWER** button for about 10s to force shutdown.

Q8: Can this unit charge other devices while it is being charged?
A: No.

Q9: Can this product charge other devices while starting a vehicle?
A: No.

Q10: How often does this unit need to be recharged??
A: It would be best to recharge it every 3 months.

12

YESPER

Q11: Why it shuts off in 30s when charging other devices?
A: This unit may shut off automatically when charging for the devices that need light charging current, such as headphone, smart watch, etc since there is minimum load current limitation (200mA) on this unit, so please use **Low Current Mode** when you are facing such problem.

Warning
1. Please read this user manual carefully before using this machine.
2. Please be careful when using this machine. If you do not follow the instructions, you may injure yourself or damage the equipment or vehicle battery.
3. Do Not allow people who do not have proper knowledge or ability to operate the device without supervision.
4. Do Not use this unit as a toy. Keep it away from children to avoid accident.
5. This unit work for vehicles (equipment) with 12V battery, doesn't for vehicles with non-12V battery. It is forbidden to be used in other machines, such as airplanes and ships.
6. Do Not use this unit when any cable, clamp, or cord was damaged or when this unit was overheated, swelled or leaking fluid.

13

YESPER

7. Do Not use it as a vehicle battery or a battery charger.
8. Do not use the unit to start a vehicle while charging the internal battery.
9. Only use the jumper cable provided to start vehicle and the qualified charger to charge this unit.
10. Don't over-discharge the unit (don't let the battery run out), charge it regularly, preferably every 3 months.
11. Make sure the plug of the jumper cable is plugged fully into the battery clamps output port, otherwise, the plug could be melt.
12. Make sure the battery terminals are clean before starting up, and make sure the battery clamps are well connected. If the battery terminals on the vehicle are dirty or corroded, the output power of the unit will decrease.
13. Do not start the vehicle continuously for more than 4 times within 10 minutes. If the engine fails to start successfully within 3s after the first start, stop cranking and wait at least 30s to start the vehicle again.
14. Do Not connect the jump starter's clamps to the battery reversely after pressing the “**BOOST**” button to avoid accident.

14

YESPER

15. Use this unit to start the vehicle when the battery power is more than 20%.
16. Do not recharge this product immediately after starting the vehicle, please let it cool for 30 minutes before recharging it.
17. Do Not let the product be immersed in water
18. Do not operate this product in an explosive environment, such as a place where flammable liquid, gas or dust exists.
19. Do not modify or disassemble this machine. Only service technicians can repair this equipment.
20. Do not expose the product to extreme heat or fire.
21. Do not drop or squeeze the device. If the device is hit hard or damaged in any other way, it should be inspected by a qualified battery technician.
22. Do not store in places where the temperature may exceed 60°C/140°F.
23. Only charge at ambient temperature of -10-45°C/14-113°F.
24. Under extreme conditions, the battery may leak. If there is a liquid leak from the device, do not handle it with bare hands. If there is skin contact, wash immediately with soap and

15

YESPER

water. If the liquid accidentally touches the eyes, immediately rinse the eyes with water for at least 10 minutes and seek medical help.

25. The device contains a lithium battery. At the end of the product's service life, or if the device leaks liquid, dispose of the device according to local regulations.

Your Warranty Includes

- **18 Months Online After-Sales Service**
Within 18 months, we will provide timely and effective online after-sales service after your purchase.
- **30 Days Money Back Guarantee**
Within the first 30 days after your purchase, you can apply return for it through seller when you have any issue.
- **30 Days to 18 Months**
We will replace the defective unit due to manufacturing issues with a new one within 18 months.

16

YESPER

Disclaimer

- When the product needs to be repaired or replaced, the original purchaser should show the original receipt (order ID), and the warranty will take effect.
- The warranty does not cover damage or product failures caused by normal wear and tear, physical abuse, improper installation, misuse, modification, or unauthorized third-party repairs.
- We are not responsible for any accidental or indirect damage caused by incorrect use or misuse of this product.
- All warranty claims are limited to repair or replacement of the defective product and at the sole discretion of YESPER.

17

YESPER

WARRANTY INFORMATION:

-12+6 Months Online After-Sales Service
Within 12 months, we will provide timely and effective online after-sales service after your purchase. If you register on our official store: yes-per.com and become our member customer, you will get extra 6 months service, total 18 months.



Scan to be our member for extending more 6 months warranty

-30 Days Money Back Guarantee
Within the first 30 days after your purchase, you can apply return for it through YOUR SELLER when you have any issue.

-30 Days to 12 Months (18 Months for Member Customers)
We will replace the defective unit due to manufacturing issues with a new one within 12 months; if you are our member customer, within 18 months.

18

YESPER

Attention

- Do Not Submerge in Water
- Do Not Disassemble
- Do Not Drop
- Avoid Extreme Temperatures
- Do Not Place Near or Into Fire



19

YESPER

Customer Service

- 12+6 Months Limited Warranty Service
- Lifetime Technical Service
- Feel Free to Contact Us
cs@yes-per.com
- For FAQ and More Information
yes-per.com

20

YESPER
Don't Say Desperate, Say Yesper!

Thank You for Choosing



Made in China

