

# MAGIC BOOK 2



**2.48**  
μmol/J







## FEATURES

Solution	PPF	AC Power	Light Source	Efficacy
MB2-660W27-V1-XX	1626 μmol/s	660W	Samsung/OSRAM	2.48 μmol/J

1. Full spectrum with enhanced red for full cycle grows.
2. Efficacy is up to 2.48 μmol/J.
3. Easy to install, just plug and play.
4. Using Samsung LM301b & Osram LED Chip.

## SPECIFICATIONS

Weight	22.05lbs/10kg
Spectrum	V1 F1 E1 T1
AC Input Voltage	120-277V AC 347-480V AC 50/60Hz
Mounting Height	≥ 6" (15.2 m) Above canopy
Thermal Management	Passive
Max. Ambient Temperature	95 F / 35 C
Dimming	0-10V Dimmable
Total Harmonic Distortion (THD)	15%
Warranty	5 Years Standard Warranty
BTUs	1980 BTU/hrs

# SPECTRA

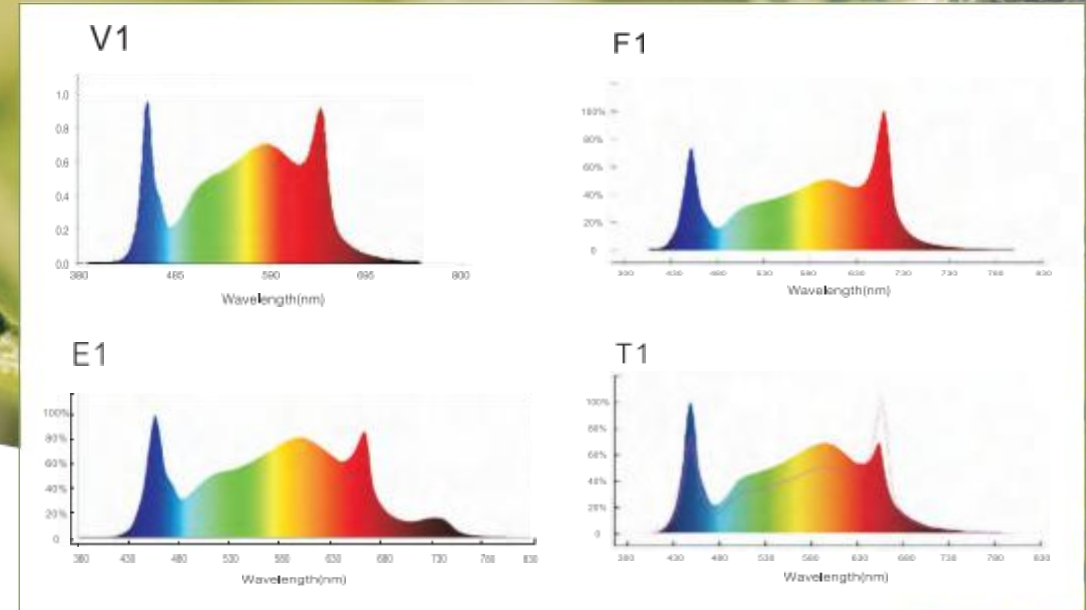

## ELECTRICAL PARAMETERS

Model	MB2-660W27-V1-XX						
AC VOLTAGE	120V	208V	230V	277V	347V	400V	480V
Power Factor	0.98	0.95	0.94	0.93	0.93	0.92	0.9
AC Current	5.61A	3.34A	3.06A	2.56A	2.05A	1.79A	1.53A
AC Power							

\* At 77° F (25° C) ambient temperature

## DIMENSIONS

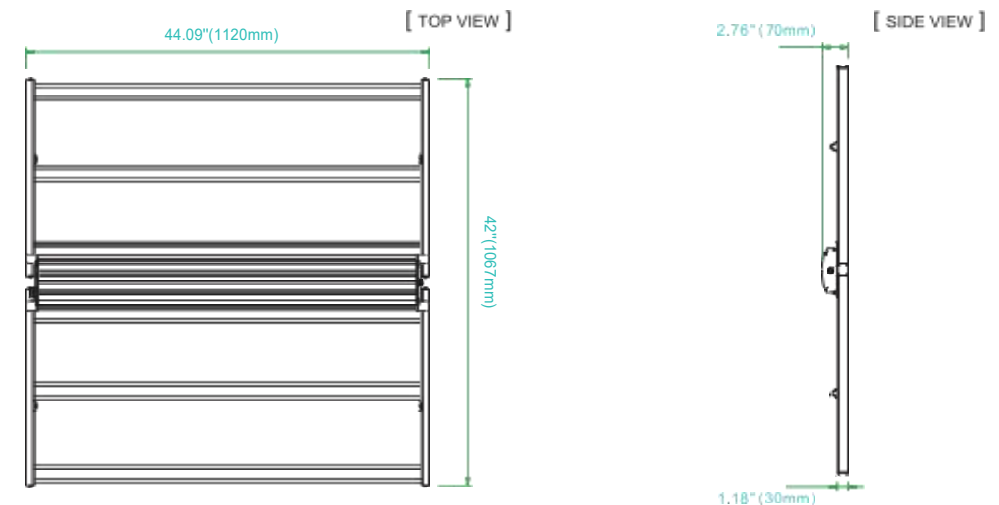

### LUMINOUS INTENSITY DISTRIBUTION DIAGRAM

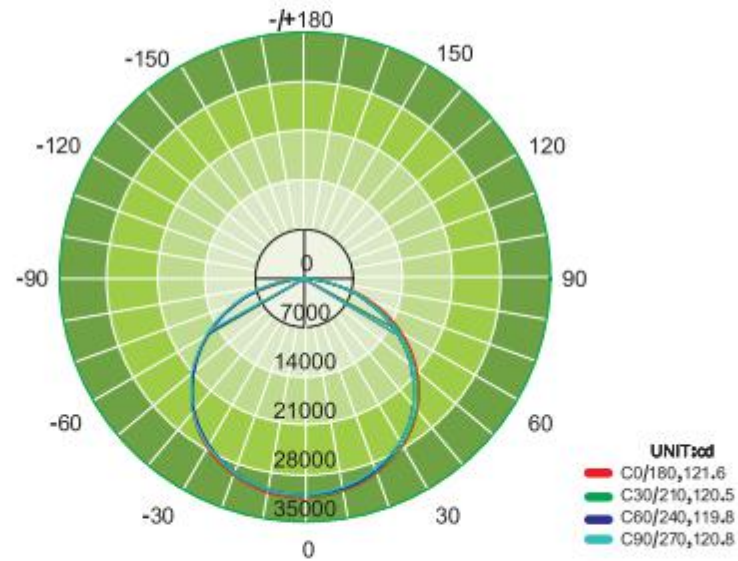

AVERAGE BEAM ANGLE(50%):120.7 DEG

### PPFD DISTRIBUTION

1.2M X 1.2M/ 4FT X 4FT

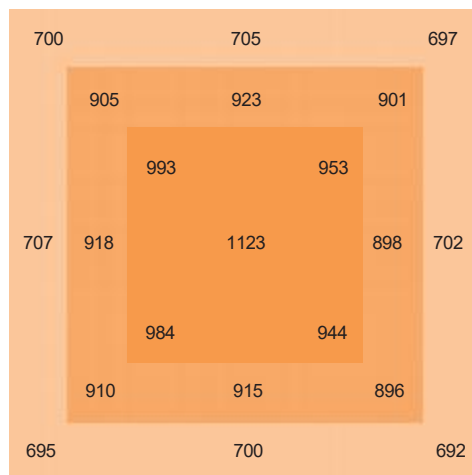

MB2-Compact 660W2.48μmol/J  
12"/305mm Height

1.2M X 1.2M/ 4FT X 4FT

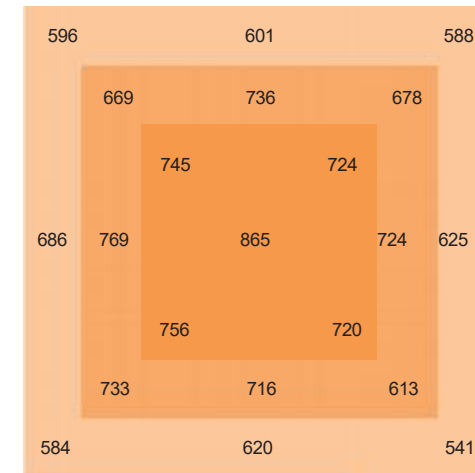

MB2-Compact 660W2.48μmol/J  
24"/609mm Height

### PAR VALUE (μmol/m²/s)

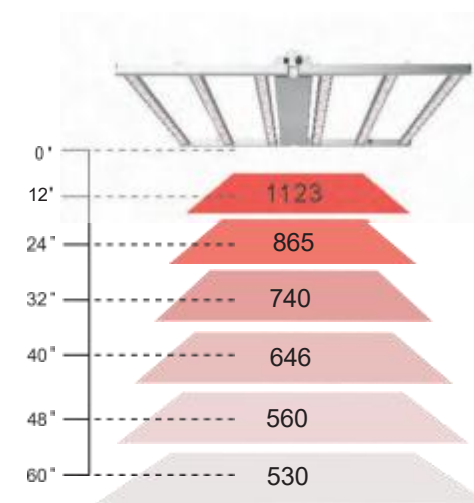

MB2-Compact 660W2.48μmol/J

## LED GROW LIGHT INSTRUCTIONS

### Matters needing attention:

To users:thank you for purchasing our products!  
Please read carefully before use,please keep this manual for reference!  
In order to ensure safe construction,please confirm the following important matters before each work begins:

- 1.Risk of fire or electric shock: turn off power before installing.
- 2.Always use product within Safe Working Load.
- 3.Designed for statically positioned hanging.Do not use for lifting or with dynamic positioning.
- 4.Do not walk or stand on product.
- 5.Always use manufacturer supplied and specified cables. Never use uncoated cables.
- 6.Do not apply oil or any other lubricant to the fastener or any other part of the cable assembly.

### Installation steps :

⚠ The Osram red chips are fragile, please don't touch it!

