

14+

# ZINC x FORMULA

**GZ<sup>1</sup>SERIES FOLDING ELECTRIC SCOOTER**

## **OWNER'S MANUAL**



### **WARRANTY**

So that your warranty is valid please register at

**[WWW.ZINCSPORTS.COM](http://WWW.ZINCSPORTS.COM)**

within 30 days of receiving the product.

NOTE: Manual illustrations are for reference only. Illustrations may not reflect the exact appearance of the actual product. Specifications are subject to change without notice.

**IMPORTANT!**  
**READ CAREFULLY AND KEEP FOR FUTURE REFERENCE.**

### **CUSTOMER HELPLINE**

Hy-Pro advise you to contact us directly and not to return this item to the place of purchase. Hy-Pro has taken great care to ensure this item has reached you in good condition, should you have a query please ring our helpline +44(0) 800 731 0006 where your call will be dealt with promptly. Alternatively, please contact us by email: [customerservices@zinchq.com](mailto:customerservices@zinchq.com)

# CONTENTS

PRODUCT OVERVIEW .....	2
SAFETY WARNINGS - READ BEFORE USE .....	3-4
BEFORE YOU START / ASSEMBLY .....	5-6
DIGITAL DISPLAY / TYRE INFLATION .....	7
OPERATING RANGE / CHARGING THE BATTERY .....	8
BATTERY WARNING / BATTERY DISPOSAL .....	9
HARDWARE MAINTENANCE .....	10
TROUBLE SHOOTING GUIDE .....	11
ERROR WARNING CODES .....	12
SPEC / WARRANTY .....	13

## PRODUCT OVERVIEW



# SAFETY WARNINGS - READ BEFORE USE

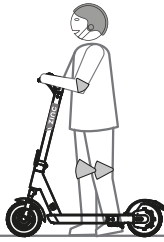

⚠️ Ensure you are at least 14 years old to ride this scooter



⚠️ DO NOT ride over speed bumps, thresholds, or other bumps at HIGH SPEED.



⚠️ DO NOT use when raining or freezing.

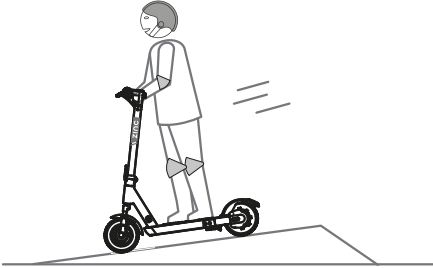

⚠️ Watch your speed when traveling downhill.

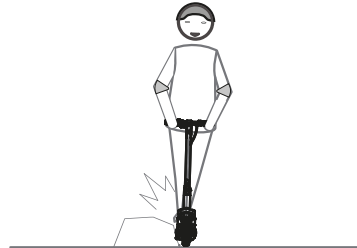

⚠️ Avoid contacting obstacles with the tyre/wheel.

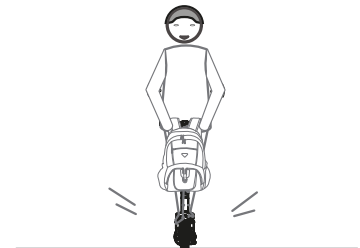

⚠️ DO NOT hang anything on the handlebar.

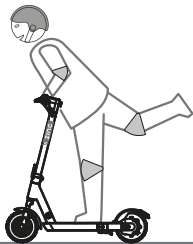

⚠️ DO NOT ride the scooter with only one foot.

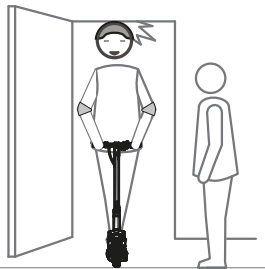

⚠️ Watch your head when passing through doorways.

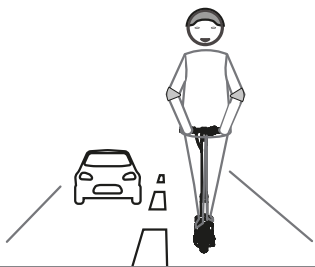

⊗ DO NOT ride on public roads, motorways, or highways.

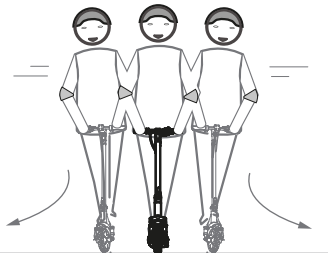

⊗ DO NOT rotate the handle violently while driving at high speed.

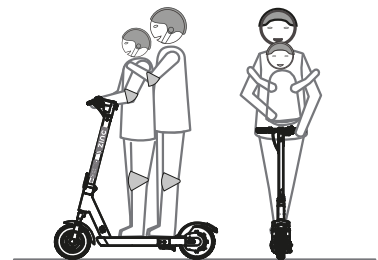

⊗ DO NOT ride with multiple passengers. DO NOT carry a child



⊗ DO NOT trample the rear end of the fender.

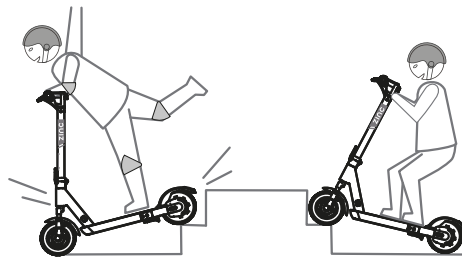

⊗ DO NOT ride up and down stairs or jump over obstacles.

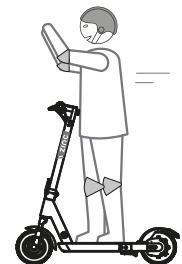

⊗ DO NOT take your hands off the handlebar while riding. Do not ride with one hand only.

**WARNING: BE SURE THAT YOU ARE IN A SAFE PLACE AND OPEN AREA BEFORE STARTING YOUR SCOOTER. NEVER START THE SCOOTER UNTIL YOU HAVE TAKEN GOOD HOLD OF THE HANDLEBARS AND BALANCE YOURSELF ON THE SCOOTER.**

# SAFETY WARNINGS - READ BEFORE USE

For your safety, please read the safety warnings carefully, and make sure you understand and accept all the safety instructions. The user will be responsible for any loss or damage caused by improper use.



**WARNING!** - Not for riders under the age of 14.

Do not exceed the height limit of 7ft and the weight limit of 100kg. This includes backpacks and other items that might be carried.

Exceeding the weight limit could injure the rider and damage the scooter.

Be sure to regularly inspect and service the scooter and make sure all components are in good condition.



**WARNING!** - The A-weighted emission sound pressure level at workstations, where this level does not exceed 70dB(A).



**WARNING!** - After unpacking this product and before you first ride it, remember to charge it for at least 4 hours.

1. Please wear all appropriate safety and protective gear such as helmet, knee, elbow pads and protective gloves, before operating the scooter.
2. Wear comfortable clothes and flat, closed toe shoes when operating your scooter. Keep laces tied.
3. Do not ride your scooter near motor vehicles or on public roads/ overcrowded areas. It's the user's responsibility to ensure that their electric scooter is used in accordance with all local and country laws. Notify your presence when approaching a pedestrian or cyclist when you are not seen or heard. Cross the protected passages while walking.
4. Do not operate the scooter while under the influence of drugs and/or alcohol.
5. Do not operate the scooter when you are restless or sleepy.
6. Do not turn sharply, especially at high speeds.
7. Do not drive in or near puddles of water, mud, sand, stones, gravel, debris or near rough and rugged terrain.
8. The scooter can be used on paved roads that are flat and even, keeping a safe distance from other road users. If you encounter uneven pavement, please lift your scooter over and past the obstruction.
9. Do not ride in inclement weather: snow, rain, hail, sleet, on icy roads or in extreme heat.
10. Do not operate the scooter while talking, texting, or looking at your phone.
11. The scooter is intended for use by one person, DO NOT attempt to operate the scooter with two or more people.
12. Do not carry anything in your arms or attach any load to the handlebar while riding the scooter. It will affect the stability of the scooter.
13. At higher speeds, always take into consideration your stopping distance is increased.
14. Do not ride the scooter in dark or poorly lit areas.
15. This scooter is not intended for acrobatic/off-road use. Do not divert the use of this scooter.
16. Applying brakes too hard or too suddenly can lock up a wheel, which could cause you to lose control and fall. Sudden or excessive application of the brake may result in injury or death. The brake may become hot in use. Do not touch after use.
17. As with any mechanical component, a vehicle is subject to high stresses and wear. The various materials and components may react differently to wear or fatigue. If the expected service life for a component has been exceeded, it may break suddenly, therefore risking causing injuries to the user. Cracks, scratches and discoloration in the areas subject to high stresses indicate that the component has exceeded its service life and should be replaced.
18. Traffic in the city has many obstacles to cross such as curbs or steps. It is recommended to avoid obstacle jumps. It is important to anticipate and adapt your trajectory and speed to those of a pedestrian before crossing these obstacles. It is also recommended to get out of the vehicle when these obstacles become dangerous due to their shape, height or slippage.
19. Keep plastic covering away from children to avoid suffocation.
20. Do not ride indoors or on surfaces that could become damaged such as carpet or glossy flooring.
21. Check all the fasteners and bolts are securely tightened before each use, in particular the wheel axles, the folding system, the steering system and the brake shaft.
22. Riding the scooter is not advisable for persons with heart disease, pregnant women, people with illness, disabilities or who have recently had an operation. There is always a risk of injury and riders should carefully assess their own health and physical condition. If they are in any doubt as to their fitness to ride the scooter, they should consult with their GP beforehand.
23. Do NOT ride the scooter in wet or icy weather and never immerse the scooter in water, as the electrical and drive components could be damaged by water or create other possibly unsafe conditions.
24. Do not make any modifications that are not noted in the manufacturer's instructions.
25. Do not use any accessories and additional items which are not approved by the manufacturer.
26. Make sure the steering system is correctly adjusted, all connection elements are tightened and not broken, and the brakes and wheels are in good condition.
27. Eliminate any sharp edges caused by use.
28. Take the time to learn the basics of the practice to avoid any serious accident that can take place in the first months.
29. Take care of yourself and others while riding the scooter.

## Weight Restrictions

Maximum Weight: 100 kg

## Speed Limits

Maximum Speed: 15.5mph/25kph



## Please Notice

Speed and weight limits are set for your own safety. Please do not exceed the limits listed in the User Manual.

# BEFORE YOU START



Allow at least 4 hours for initial charge.  
By not doing so you will invalidate the warranty.

Before you first experience your Zinc Formula E GZ<sup>1series</sup> Folding Electric Scooter, please read the USER MANUAL thoroughly and learn the basics to ensure your safety and the safety of others.

**WARNING** Failure to follow the basic instructions and safety precautions listed in the USER MANUAL, can lead to damage to your scooter, other property damage, serious bodily injury and even death.

**Adult assembly required.**

The tyres should have good air pressure, but some air may have escaped.

Please inflate the tyres if they do not have enough air pressure.

Allow at least 4 hours for initial charge. By not doing so you will invalidate the warranty.

Warning! Upon unpacking, please check the contents against the packing list. Before assembling the scooter, please check whether the power switch is in the "OFF" position, if not, please put it in the "OFF" position before continuing with assembly.

## ASSEMBLY:

- Assembly can typically be completed in up to 10 minutes, not including the initial charge time.
- Time of charging is at least 4 hours for the first time.

- 1) Pull up the stem until it clicks and locks into place.  
Close the front clasp to confirm it is locked.
- 2) Manually connect the data cable in the stem tube, and check it turns on to check the connection.

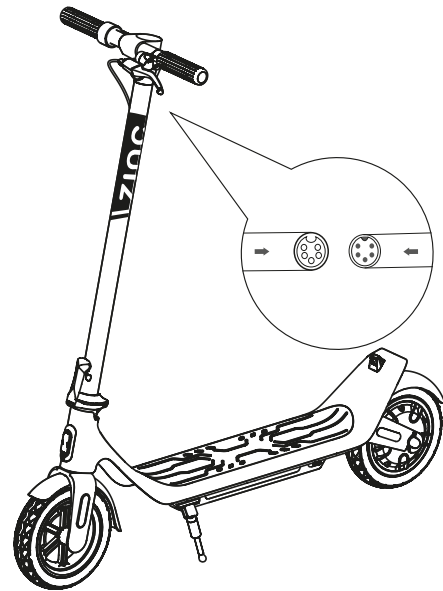
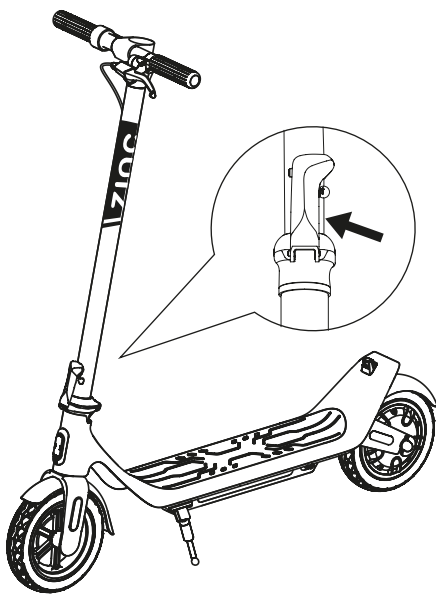

- 3) Insert the handlebar into the stem tube, and use the T-Shaped Allen Key to tighten the six screws.

- 4) Test the power switch after assembling.

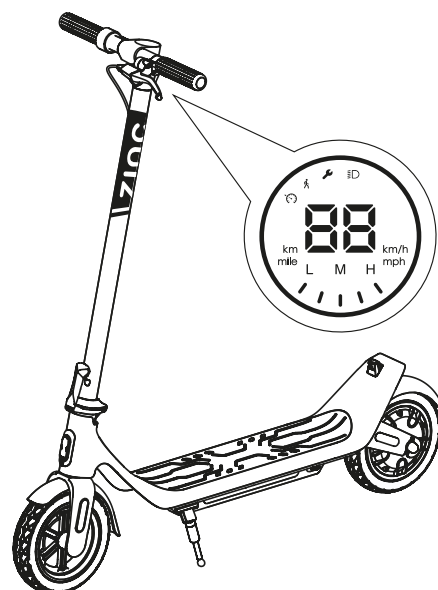
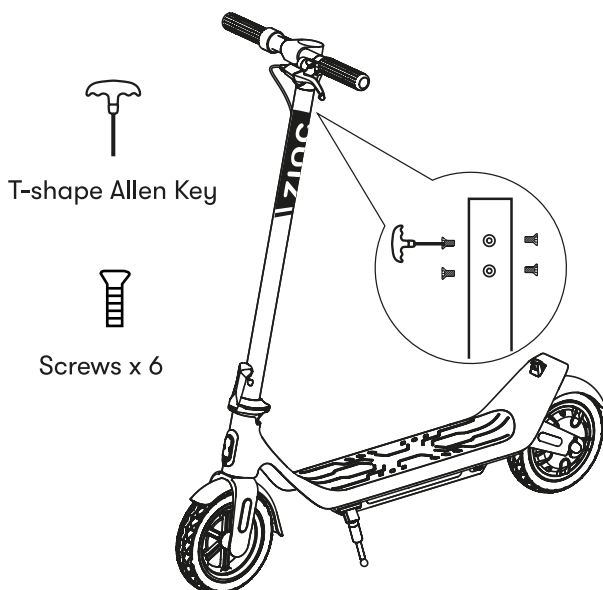

# BEFORE YOU START

## UNFOLDING AND FOLDING THE SCOOTER:

### Unfolding the Scooter

You can unfold the Zinc Formula e GZ<sup>1series</sup> Folding Electric Scooter without any inconvenience in seconds.

- Release the stem from the Folding Catch.
- Pull the stem upright, until it clicks into place.
- Flip the Folding Lock to lock the handlebar in place.

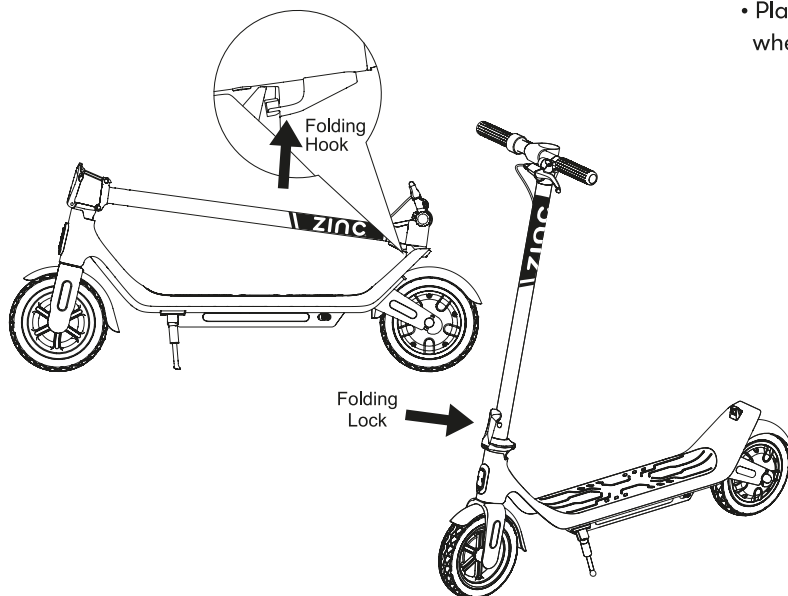

### Folding the Scooter

The Zinc Formula e GZ<sup>1series</sup> Folding Electric Scooter can be folded in a few seconds.

- Turn off the Scooter.
- Flip the Folding Switch up and pull open the Folding Lock. Fold and lower the front stem down to the rear wheel.
- Place the folding hook on the front tube into the Folding Catch where it will lock in place.

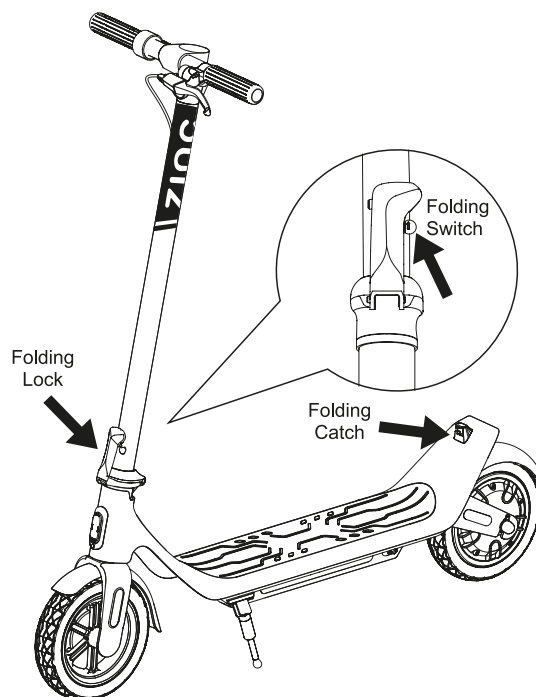

Warning: There is risk of falling down during learning, so make sure to wear helmet and protection kits all the time.

Never stand on, or lift the scooter from the rear wheel fender.

## TURNING ON YOUR SCOOTER:

1. Turn on the scooter by pressing the power button and check the battery power. Note: The display shows the estimated distance range of remaining battery level.
2. Once the power is on it is safer to start riding. With one foot on the deck keeping the other foot on the ground - push off and press the accelerator, placing the other foot on the deck. Note: For your safety, the motor will not engage until the scooter reaches 3.1mph/5kph.
3. To stop riding, release the accelerator and use the brake to gradually stop then step off the scooter one foot at a time. Be extra cautions when dismounting for the first time. Then unfold the kick stand to support the scooter.
4. Turn off the scooter by pressing and holding the power button for 3 seconds when you have finished riding the scooter. Note: The scooter will turn off automatically if it has not been used for 5 minutes.

There is a Warning Bell, near the brake lever, to warn pedestrians of your approach.

### Cruise Control Function

You can set up the speed as you want during the driving, and the scooter will start moving on the same speed afterwards. Press the accelerator right thumb and keep the same speed for 6 seconds and the cruise control will automatically enter and you can hear a beep sound. You can switch the function off easily when you press the brake lever/ accelerator.

### Automatic Light Sensing Function

When the surrounding light is not enough, the onboard sensor will automatically turn on the headlight, rear light and deck lights. When the surrounding light is enough, the lights will turn off automatically. Note: When the scooter is powered on, you can turn the lights ON/OFF by pressing the power key once. It will deactivate the Automatic Light Sensing Function. You can reactivate this function by restart the scooter.

### Smart Turn Signal

When the scooter reaches 3.1mph/5kph, it judges the riding direction and turns on the 'Turn Signal' automatically when the steering angle reaches 15° ~ 20°. When turning left, the left ambient deck light flashes; when turning right the right ambient deck light flashes.

### Gyroscope Assist Driving Function

The gyroscope determines the up and down slope according to the forward speed/tilt angle, and the intelligent speed regulation makes the vehicle ride smoothly. If the vehicle attitude is dumped to left/right side at 45 degrees or over, the scooter will cut the power automatically (it will happen only when scooter is in cruise control).

### Pedestrian Mode

When the scooter is at L gear mode, the deck lights will flash.

Warning: DO NOT step on the rear fender, it is NOT a brake. It is also prohibited for lifting.

# DIGITAL DISPLAY

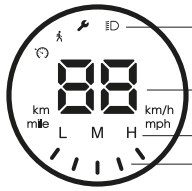

Function mode

Speedometer

Gear mode

Battery level

**Function mode:** Cruise mode, Pedestrian mode, Fault prompt, Light.

**Speedometer:** Displays the current speed; displays the remaining mileage within 6 seconds after power-on.

**Gear mode:** The maximum speed limit is 3.7mph/6kph for L gear (Pedestrian Mode), 9.3mph/15kph for M gear and 15.5mph/25kph for H gear. Press the Switch Button two times to change the gear mode.

**Battery level:** Each battery level indicates 20% of battery usage. When the last battery light turns to red, it indicates 10% battery remaining. The battery should be charged as soon as possible.

**Switch Button:** Turn on the scooter – press it once. Change the gear mode – press it 2 times consecutively. Change the speed unit – press it 3 times consecutively. Turn on/off the front light – press it once. Turn off the scooter – press and hold for 3 seconds.



## Service Warning - Please note:

If this light comes on the scooter will require a service.

User should stop using the scooter immediately and contact

Hy-Pro's Customer Service Line +44 (0) 800 731 0006.

# TYRE INFLATION

Pump - not included.

Valve connector - included

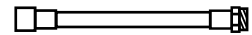

**Both tyres should have good air pressure, but some air may have escaped. Please inflate the tyre if it does not have enough air pressure.**

**Recommended tyre pressure is 45-50psi.**

**To inflate:** remove the dust cap on the wheel valves, and use the valve connector provided, with a suitable hand/foot pump, to inflate to maximum of 50psi.

**Warning:** It is very important to regularly check and maintain the tyres as the tyre pressure directly impacts the safety and performance of the scooter. Don't over inflate the tyre as excessive tyre pressure may cause damages to the tyre and wheel, while insufficient tyre pressure may reduce the maximum speed.

# OPERATING RANGE

Please notice the scooter can travel a distance of 12.4 miles / 20km on a fully charged battery in ideal conditions. The following are some of the major factors that will affect the operating range of your scooter.

**Terrain:** A smooth, flat surface will increase your driving distance, while driving uphill, as well as rough or uneven terrain will reduce your distance significantly.

**Weight:** The weight of the user can affect driving distance, a lighter user will have further range than a heavier user.

**Ambient temperature:** Please ride and store the scooter under recommended temperatures, which will increase driving distance, battery life, and overall performance of your scooter.

**Maintenance:** Reasonable battery charging and maintenance will increase the distance. Overcharging the battery can reduce range.

**Speed and Driving Style:** Maintaining a moderate speed will increase your distance; while travelling at high speeds for extended periods, frequent starts, stops, idling, along with frequent acceleration and deceleration will reduce your overall distance.

# CHARGING THE BATTERY

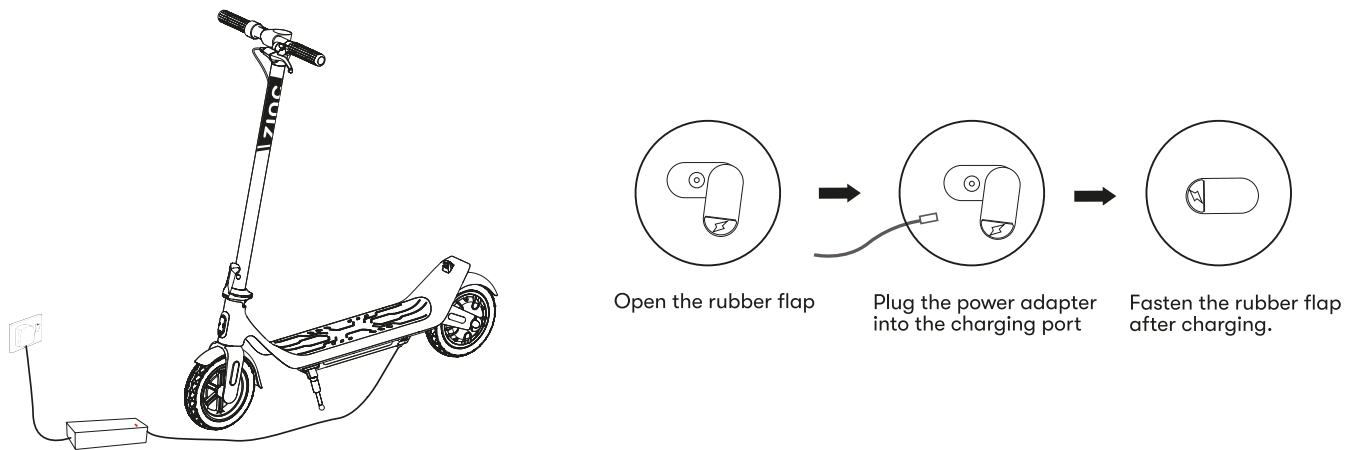

For user safety and to prolong the life of your battery, as well as improve battery performance, please follow these instructions.

**Step 1:** Ensure your scooter is turned off before you attempt to charge the battery.

**Step 2:** Ensure that the charging port is clean and dry.

**Step 3:** Plug the charger into the power socket, then connect the cable with the power supply (100V~240V; 50/60Hz), make sure the light on the charger is lit GREEN.

**Step 4:** Put the male DC connector plug into the charging port of the scooter. The indicator light on the charger should change to RED, indicating that your scooter is now being charged. When the RED indicator light on your charger turns to GREEN then your scooter is fully charged. A full charge typically occurs at 4 hours.

**Step 5:** Please unplug the charger from your scooter and from the power outlet. Please ensure you put the charging port cover back in place to cover the charging port once the battery is charged, before you use the scooter.

## ⚠ IMPORTANT NOTES ABOUT CHARGING

If the green light on your charger does not turn RED when you plug it into your scooter, it could mean you have to check the cables to ensure you have a proper connection; or that your scooter is already fully charged.

- Do not overcharge as this will affect the life of the battery and may cause overheating which can lead to a fire hazard. Never charge near flammable materials or liquids.
- The best charging temperatures are between 0°C~40°C. Extreme cold and extreme heat will prevent your battery from charging fully.
- Make sure to unplug your charger before standing on or operating your scooter, as this can be very dangerous.
- Use only the charger and charging cable supplied by Hy-Pro. Use of any other charger or cable may lead to damage to the product, overheating and risk of fire. Use of any other charger or cable voids the warranty.
- The charger is not a toy, it should be operated by an adult.
- Once your scooter has been charged, unplug the charger from the wall outlet and then from the scooter. Do not leave the scooter on charge overnight and do not leave the scooter unattended whilst on charge.
- In an ideal situation, you would have somewhere secure to store/charge your scooter, such as a shed or garage. It would also be desirable for this area to have plugs where you can charge your scooter.

NOTE The charger itself may get quite warm to the touch when charging a deeply discharged battery.



# BATTERY WARNING

## BATTERY SPECIFICATIONS

Battery	Lithium Battery
Charging time	4 hours
Voltage	36.5V
Initial Capacity	5200 mAh
Working Temperature	0° C ~ 40° C

Charging Temperature	0° C ~ 40° C
Storage Time	6 months
Storage Temperature	-20° C ~ 50° C
Storage Humidity	Relative Humidity 5%-95%

## BATTERY WARNING

Failure to follow the Safety Precautions listed as below could lead to serious bodily injury and death.

Seek immediate medical attention if you are exposed to any substance that is emitted from the battery.

- Do not disassemble or modify the battery. The battery contains safety and protection devices, which, if damaged, may cause the battery to generate heat, explode or ignite.
- Do not use your scooter if the battery begins to emit odor, overheats, smokes, changes colour/shape, or appears abnormal in any other way.
- Do not touch any leaking materials, or breathe fumes emitted.
- Do not allow children and animals to touch the battery.
- The battery contains dangerous substances, do not open the battery, or insert anything into the battery.
- Do not connect the positive terminal and negative terminal of the battery to each other with any metal object (such as wire).
- Do not attempt to charge the scooter if the battery has discharged or emitted any substances. In that case, the battery should be abandoned for safety.
- Please follow all local, state and federal laws in regards to recycling, handling and disposing of Lithium batteries.
- Do not carry or store battery together with necklaces, hairpins or other metal objects. Do not pierce the battery with nails, strike the battery with a hammer, step on the battery or otherwise subject it to strong impacts or shocks. Do not expose battery to water, or allow the battery to get wet.
- Do not place the battery in an environment where the ambient temperature is higher than 50°C or lower than -20°C (e.g. do not leave the scooter or the battery pack in a car under direct sunlight for an extended time). Do not throw the battery pack into fire as it may lead to battery failure, battery overheating, and even another fire. If the scooter is expected to be left idle for more than 30 days, please fully charge the battery and place it in a dry and cool place. Keep in mind to recharge it every 30 days to protect the battery from potential damage which is beyond limited warranty.

## BATTERY DISPOSAL



**Do not store the battery in temperatures above 50° C or below -20° C.**

CONTAINS SEALED LITHIUM-ION BATTERIES. BATTERIES MUST BE RECYCLED. Your Zinc product uses sealed lithium-ion batteries which must be recycled or disposed of in an environmentally sound manner. Do not dispose of a lithium-ion battery in a fire. The battery may explode or leak. Do not dispose of a lithium-ion battery in your regular household trash. The incineration, land filling or mixing of sealed lithium-ion batteries with household trash is prohibited by law in most areas. Return exhausted batteries to a local, approved battery recycler or a local seller of automotives.

# HARDWARE MAINTENANCE

## INSPECTION, MAINTENANCE, AND STORAGE

Your scooter requires routine inspection and maintenance, it is a factor of safety. This chapter describes maintenance steps and important operating tips. Before you perform the following operations, ensure the power and charging cables are disconnected.

### INSPECTING AND CLEANING YOUR SCOOTER

- Routinely check the body of the scooter and tyres for damage or excessive wear.
- The self-tightening nuts as well as the other self-tightening fastenings may lose their efficiency and that they may need to be retightened (Average value is 15N·m).
- Wet a clean cloth with clean water, rinse the cloth thoroughly, and wipe the body of the scooter making sure that water does not get into the power button, charging port or tyres. If water or other liquids enter the scooter, it will cause permanent damage to the internal components.

### BRAKE

Check the brakes function properly.

A) When the hand brake is applied, the power should be cut and the motor will stop working.

B) Make sure the wheels are able to rotate freely, without getting stuck/any stopping when the brake is not applied.

### FRAME, FORK AND STEERING SYSTEM

Check the frame, fork and steering system for cracks or loose connections. Check all connection elements (such as a folding system) are correctly tightened and not broken. It is necessary and important to check the tightening of the various bolted elements regularly.

### WHEELS, TYRES

Wear and tear is unavoidable in the wheels and the driving system in the course of operation. The wheels are inflatable, the maximum tyre pressure is 3.5bar (50psi). The user must regularly check the wheels and the driving system for wearing and make adjustments or replacements when necessary. Please make sure the wheels are able to rotate freely, without getting stuck/stopping when the brake is not applied. It is suggested to add lubricant (30SAE lubricating oil is recommended) to the moving parts every 6 months.

### BATTERY

Always switch off the power when the scooter is not in use. Never store the scooter at a low temperature, it may damage or degrade the battery permanently.

### CHARGER

The charger supplied with the scooter should be regularly examined for damage to the cord, plug, enclosure and other parts. In the event of such damage the scooter must not be charged until the charger has been repaired or replaced.

### STORING THE SCOOTER

- Fully charge your battery before storing.
- If you are storing your scooter for an extended period of time, please fully charge your scooter at least once every month.
- If the ambient temperature of the storage location is below 0°C, please do not charge. You must bring the scooter into a warmer environment before charging.
- Check under Battery Specifications for more details.
- Store your scooter indoors, in a dry and suitable temperature.



**WARNING! - FAILURE TO FOLLOW THESE INSTRUCTIONS MAY DAMAGE YOUR PRODUCT AND VOID WARRANTY.**

# TROUBLE SHOOTING

PROBLEM	POSSIBLE CAUSE	SOLUTION
Scooter will not run.	Battery is not charged.	Charge the battery for at least 4 hours for the first charge, and at least 4 hours for subsequent charges.
	Charger is not working.	Make sure power flow to the wall outlet is on.
Scooter run time is short.	Battery requires charging.	Charge the battery for at least 4 hours for the first charge, and at least 4 hours for subsequent charges.  Make sure charger plug is connected to 100-240V power supply.
	Battery will not fully charge.	Make sure power flow to the wall outlet is on.  Battery may need to be replaced. Even with proper care, rechargeable batteries do not last forever. The average rechargeable battery life is 1 to 2 years depending on scooter conditions and use. Replace only with Hy-Pro replacement batteries.
Scooter runs sluggishly.	Scooter is overloaded.	Make sure the scooter is not overloaded. This product is designed to sustain a maximum of 100kg. An excessive overload triggers off automatic protection and makes the scooter refuse to start. Do not ride uphill a steep slope or use the scooter to tow any cargo. Do not overload the scooter, which may cause the battery and the electronics to age prematurely and damage the power system.
	Unsuitable riding conditions.	Only ride on solid, even clean and dry surfaces such as pavement and flat ground.
Sometimes the scooter doesn't run or the wrench figure on the digital display is on. 	Loose wires or connection.	Check all wire around the motors and all connectors to make sure they are tight.
	Battery requires charging.	Charge the battery for at least 4 hours if only one light of battery power is on.
	Motor or electrical switch damage.	Contact ZINC customerservices@zinchq.com for diagnosis and repair options.
The scooter motor cuts out after the scooter has been ridden up steep gradients or in situations where the maximum load has been exceeded on the scooter.	Battery Management System (BMS)	The battery incorporates a management system that will automatically cut out the power. If these situations occur, the scooter will automatically reset and run as normal. Please do not run the scooter under these conditions as the BMS will continue to cut the power as the battery and motor are being overloaded.

## SPARE PARTS:

Due to general wear and tear, occasionally you may need to purchase spare parts to keep your scooter in peak condition. It is important to use the correct spare parts for your particular model ie. ZINC FORMULA E GZ<sup>1</sup>SERIES FOLDING ELECTRIC SCOOTER, and that you purchase them directly from us.

Visit our website [WWW.ZINCSPORTS.COM](http://WWW.ZINCSPORTS.COM) and go to 'Spare Parts'.

If you have any problem selecting the parts you require, contact Zinc Customer Services on +44 (0) 800 731 0006.

# ERROR WARNING CODES

ERROR CODE	PROBLEM	SOLUTION
E0	Battery low voltage alarm	Check battery voltage or charge the scooter.
E1	Battery high voltage alarm	Check battery voltage or stop using.
E2	Controller failure	Check and replace the controller.
E3	MOS failure	Stop using the scooter for 15 minutes and restart or replace the controller.
E4	Communication failure	Check whether the displayer or controller cable is in good connection.
E5	Motor hall failure	Check whether the motor hall terminal is connected well or the motor hall is broken.
E6	Accelerator failure	Check the throttle or wiring.
E7	Brake failure	Check the brake shifter or wiring.
E8	Overcurrent protection	Stop using the scooter for 5 minutes and restart.
E9	Blocking failure	Turn off the scooter and re-start.
E10	Communication failure (Controller and battery)	Please check the cable (between controller and battery) is in good connection

If you have any problems, contact Customer Services on +44 (0) 800 731 0006 or email [customerservices@zinchq.com](mailto:customerservices@zinchq.com)

# SCOOTER SPECIFICATIONS

- Net Weight: 14.8kg
- Load: 100 kg
- Max. Speed Limit: 15.5mph/25kph
- Range: 12.4miles/20km
- Max. Climbing Limit: 8 degrees
- Battery: Lithium-ion, 5.2 Ah, 36.5V
- Charger Output: DC 42V 1.5A
- Charger Input: AC 100-240V / 50-60Hz
- Size (folded): L 111 x W 44 x H 49 cm
- Size (unfolded): L 111 x W 44 x H 116 cm
- Tyres: 9 inch front and rear vacuum tyres.

## WARRANTY

REGISTER YOUR PRODUCT AT [WWW.ZINCSPORTS.COM/WARRANTY](http://WWW.ZINCSPORTS.COM/WARRANTY)

Thank you for purchasing a Zinc electric scooter and we hope you enjoy using it. Please ensure that you read the following warranty.

In order for your warranty to be valid you must satisfy the following conditions.

- All products must be registered at [www.zincsports.com](http://www.zincsports.com) within 30 days of receiving the product for the warranty to be valid.
- Proof of purchase is also required for your warranty to be valid.
- You must be the original purchaser who bought the product from an authorised dealer, your warranty cannot be transferred.
- You must report any defects to Zinc Sports within 30 days of discovery of said defect else the warranty will not be valid.

Failure to follow the conditions highlighted above means that your warranty will be void. We recommend that you save your original sales receipt. Assuming that you have followed the conditions highlighted above, your product will have a 12-month limited warranty from defects in the materials used to manufacture, and/or workmanship at the time of manufacture outside areas covered below.

Our warranty includes:

Component:	Time Frame:
Battery	3 months
Controller	3 months
Charger	6 months
Motor	6 months
Frame	12 months
Vehicle body outside areas stipulated in the warranty	6 months

All scooters have an IP rating of IP65. The warranty will be void if the scooter has any water ingress or damage as a result of water ingress. The warranty may be void if the scooter has been used in the rain, through deep puddles, jet washing and submersion. No warranty is provided for corrosion damages as a result of contact with water/humidity conditions. All electric scooters include Liquid Contact Indicators on the battery pack. The Liquid Contact Indicators show if the device has come into contact with water or a liquid containing water, the Liquid Contact Indicators turn red when they come into contact with water or a liquid containing water. The warranty is void if the Liquid Contact Indicators are red.

Under no circumstance will Zinc Sports be obliged to provide compensation for bodily injuries, death, property damages, losses, hindrance of profits, prevention of use or any other damage that will be caused directly or indirectly as a result of usage of this device. Zinc Sports advice that you contact your insurance company to determine whether coverage is provided for the use of this scooter, or to take out a new policy.

For the full warranty policy please visit our website at <https://www.zincsports.com/>

**Product Code: ZC08275 ZINC FORMULA E GZ<sup>1</sup>SERIES FOLDING ELECTRIC SCOOTER**

Hy-Pro International  
Hy-Pro House, Centrus Park, Arenson Way,  
Dunstable, Bedfordshire, LU5 5BN, UK

[www.hy-pro.co.uk](http://www.hy-pro.co.uk)  
[www.zincsports.com](http://www.zincsports.com)  
©ZINC

Hy-Pro Europe  
Cube Building, Monahan Road,  
Cork, T12H1XY, Republic of Ireland

Hy-Pro Asia  
Room 1011, 10/F,  
Peninsula Centre, 67 Mody Road,  
Kowloon, Hong Kong

Need Help? Visit our website for product support [www.zincsports.com](http://www.zincsports.com) or email our customer service team on [customerservices@zinchq.com](mailto:customerservices@zinchq.com)