

**Important**

Use the QR code below for the most up to date instructions:



**Tools Needed for Lock Installation:**

- Phillips Screwdriver



Read this manual carefully before installing and operating!  
Model 8733500

**1 Installation Overview**

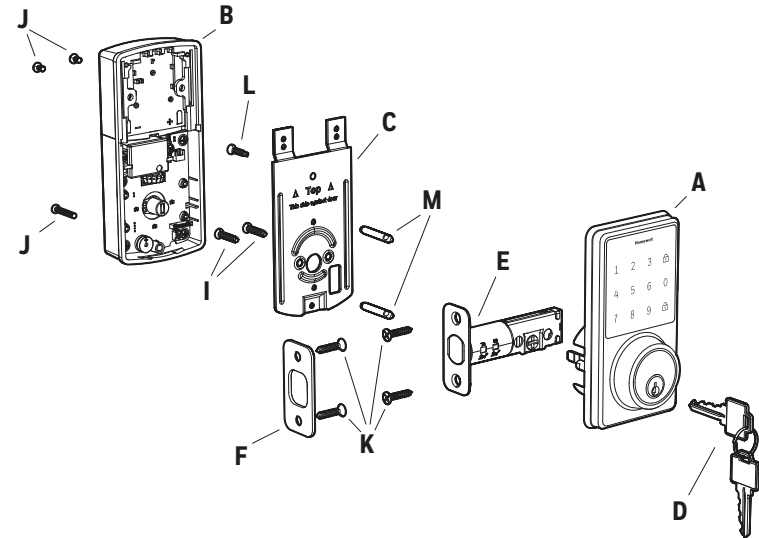

**Package Includes:**

- |                        |                    |                        |
|------------------------|--------------------|------------------------|
| 1 - Exterior Faceplate | 1 - Strike Plate   | 2 - 5/16" Screws       |
| 1 - Interior Faceplate | 1 - Mounting Plate | 2 - 1" Screws          |
| 1 - User Guide         | 1 - Latch          | 4 - 3/4" Screws        |
| 2 - Keys               | 1 - 1 3/8" Screw   | 2 - Mounting Posts     |
|                        |                    | 1 - Optional Set Screw |

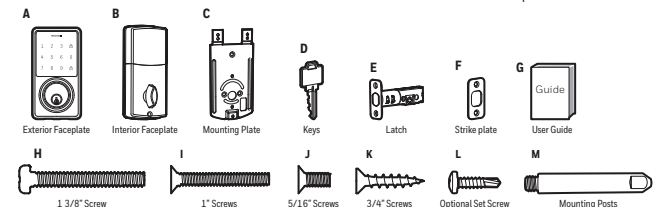

Please carefully check the above list to confirm all items have been received. If any items are missing, please contact Consumer Assistance. (See back for contact information)

**2 Install Enclosed Latch and Strike Plate**

**Do not over-tighten latch screws.**

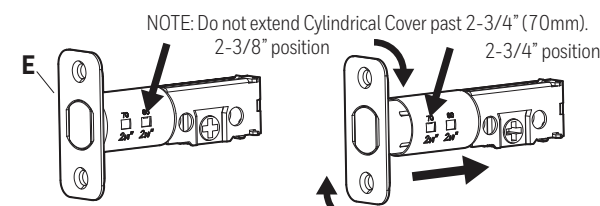

- TO CONVERT FROM 2-3/8" (60mm) BACKSET TO 2-3/4" (70mm) BACKSET:
1. Hold latch with numbers facing forward and thumb pressing on the bolt.
  2. Rotate the cylinder cover clockwise.
  3. Pull and twist the extension plate all the way out.
  4. Rotate the cylinder counter clockwise so that the marking aligns with the 2-3/4" position indicator.

**The latch plate on the door needs to be straight and not protruding from door. Make adjustment before installing or this will cause problems with bolt fitting into latch hole.**

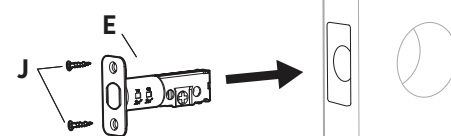

**Deadbolt Latch Must Be Retracted During Installation.**

**Preparation for Interior Assembly.**

Remove (J) Screw from inside the battery compartment within the (B) Housing to release the Mounting Plate (C).

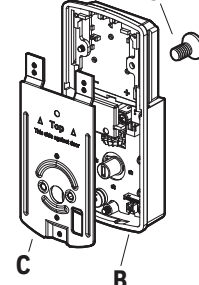

Screw Mounting Post (M) into holes on Mounting Plate (C).

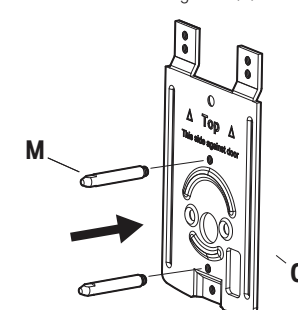

**3 Install Exterior Assembly**

**Check that the Rubber Gasket is secured on the Exterior Assembly. Insert the Exterior Assembly onto the door with the tailpiece going through the Deadbolt Latch Set in the VERTICAL POSITION.**

Route the Control Wire through the door UNDER the Deadbolt Latch Set. Make sure the door is shut, lock and unlock using the key, ensure that the latch is operating smoothly and is aligned properly without scraping the strike plate. If not, go back to step 2 and ensure you followed the steps.

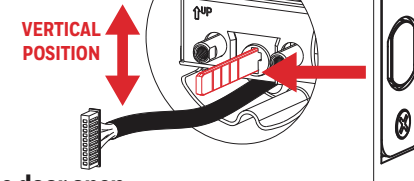

**Work with the door open**

(K) screw goes into the door to prevent the lock from shifting and is optional.

**Do not overtighten screws**

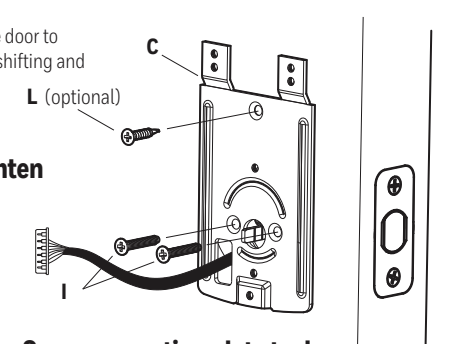

**Secure mounting plate to door**

**4 Install Interior Assembly**

**Carefully insert control wire into the wire connector**

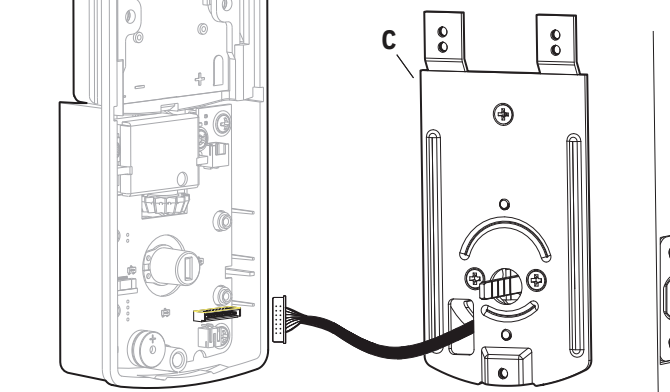

**Work with the door open**

**NOTE: Make sure the connector dots line up with the dots on the control wire**

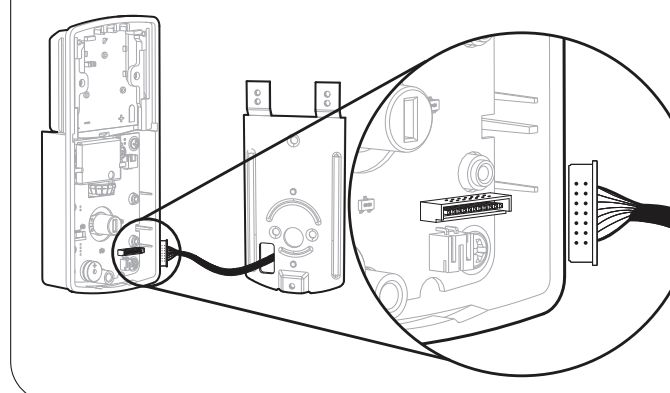

**5 Install Interior Assembly**

NOTE: Make sure the Turn Knob is in the vertical position. Be careful not to pinch the control wire when assembling.

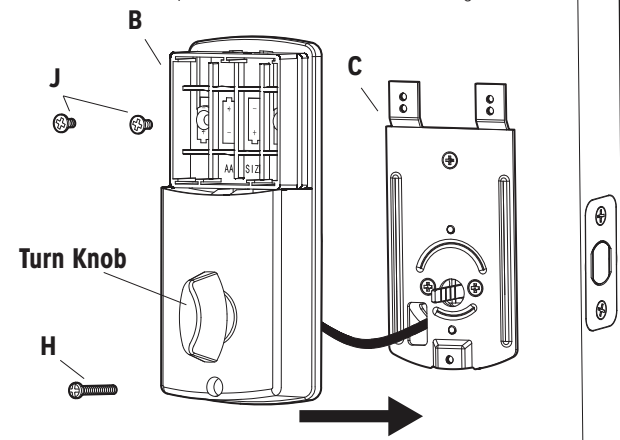

**Test the lock**

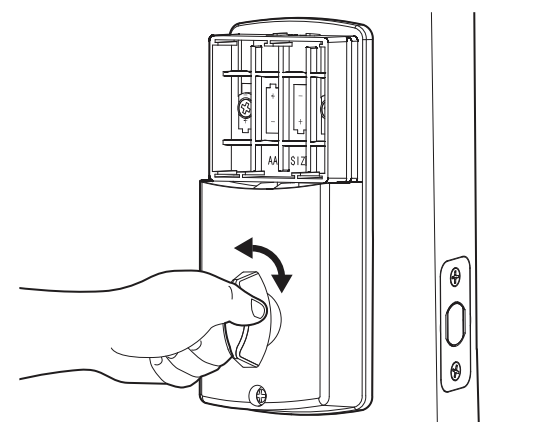

Lock and unlock using the turn knob make sure the latch is opening and closing easily. If not, go back to step 2 and ensure you followed the steps.

**6 Install Batteries and Cover**

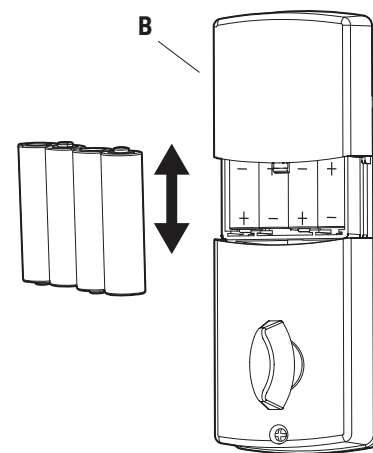

This Electronic lock requires (4) High Quality AA Alkaline batteries. When all 4 batteries are installed in the correct position, you should hear 2 beeps and the touchscreen will illuminate.

The Lock motor will engage and do a series of locking and unlocking motions in order to automatically determine your door "Handing" (left or right handed door). When completed the lock will beep and the touchscreen will flash.

**NOTE: Do not touch the touchscreen or turn knob until the light turns off.**

**Do not use rechargeable batteries or non-alkaline batteries.**

**7 Testing Operation**

**Test the lock button with door open**

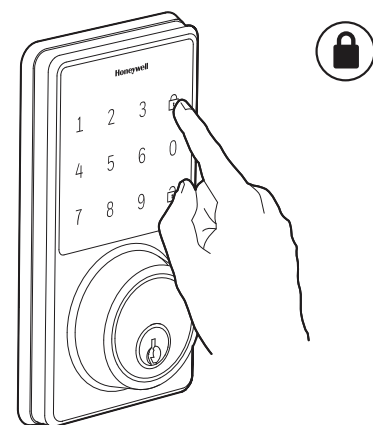

**Test unlocking**  
Press 1-2-3-4-unlock

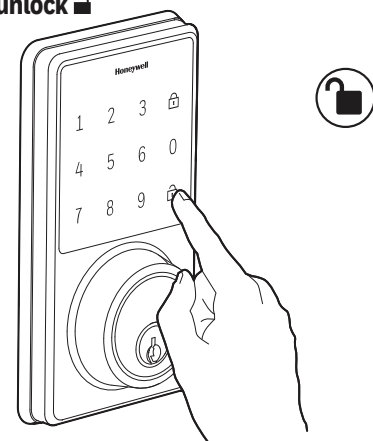

**Before Opening Door**  
Let Motor Complete Cycle

**NOTE: Let lock operation complete before attempting another action**

**Preparing Door**

**Tools Needed for Door Preparation (if there is no knob hole):**

NOTE: Skip this step if your door comes with pre-drilled holes.

- Drill
- 2 1/8" Hole Saw
- 1" Hole Saw
- 3/4" Chisel

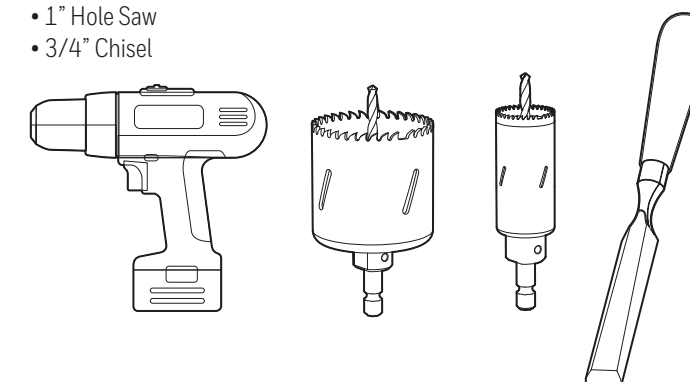

**Refer to Template included for Door Prep Instructions**

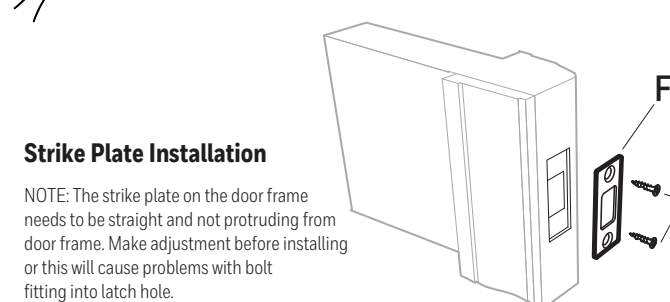
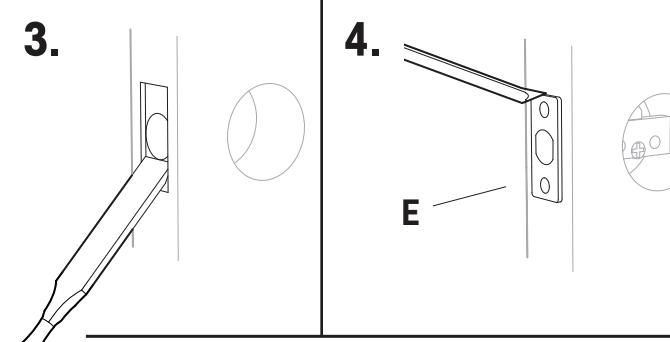
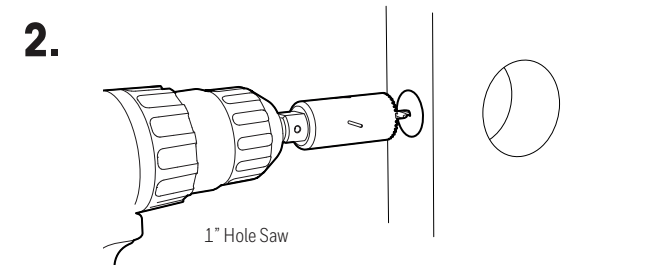
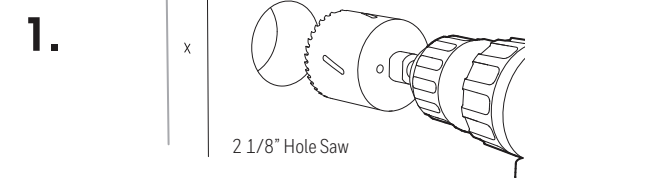
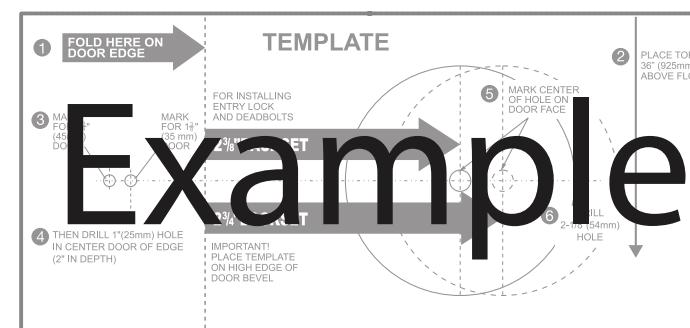

**Strike Plate Installation**

NOTE: The strike plate on the door frame needs to be straight and not protruding from door frame. Make adjustment before installing or this will cause problems with bolt fitting into latch hole.

## Programming Instructions

Read this manual carefully before Programming and operating!

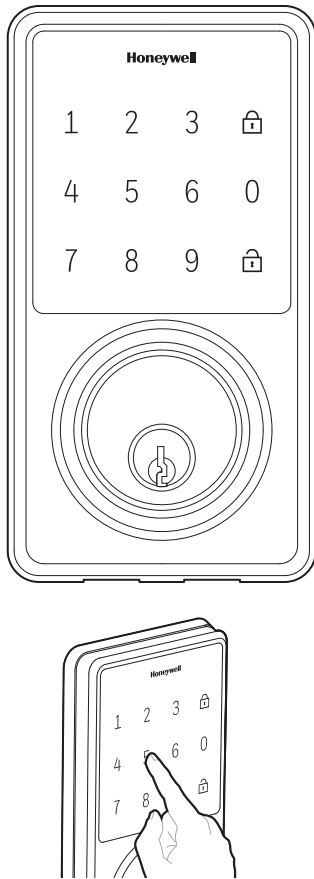

**⚠ Complete all the programming steps in the programming mode within 5 seconds. Do not press touchscreen until it stops illuminating, after you put in batteries**

## 1 Creating Administrator Code

Touch screen to wake up lock.  
Do not share admin code.

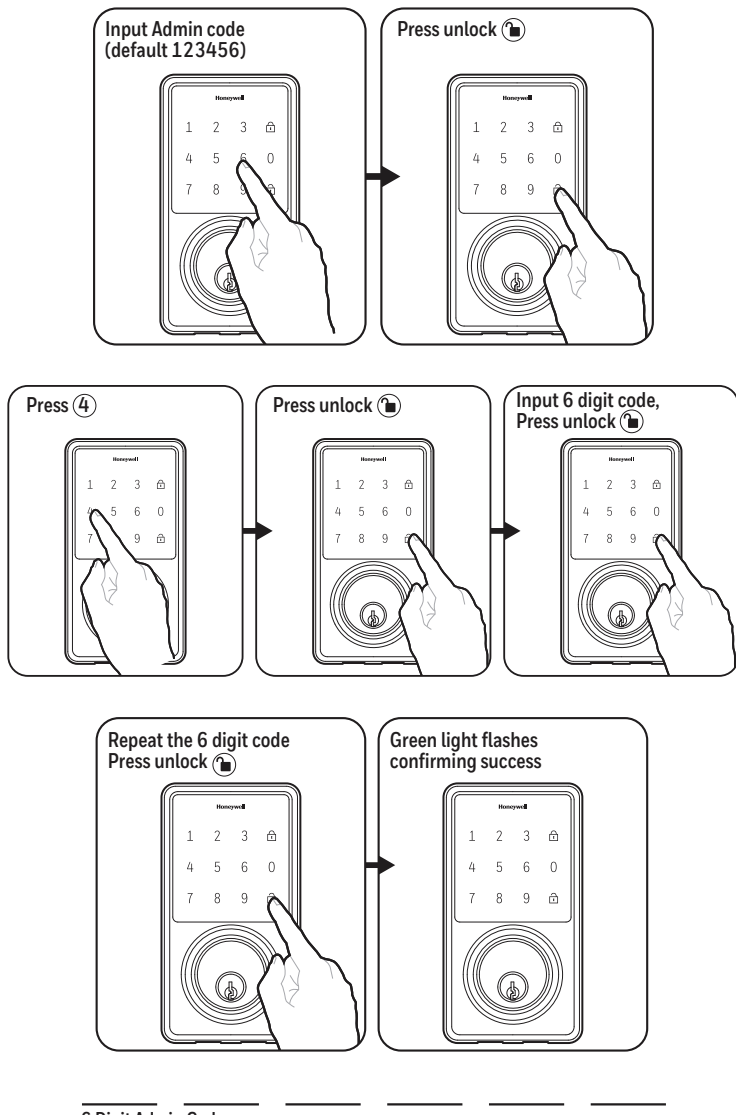

6 Digit Admin Code

## 2 Adding a User Code

Touch screen to wake up lock.

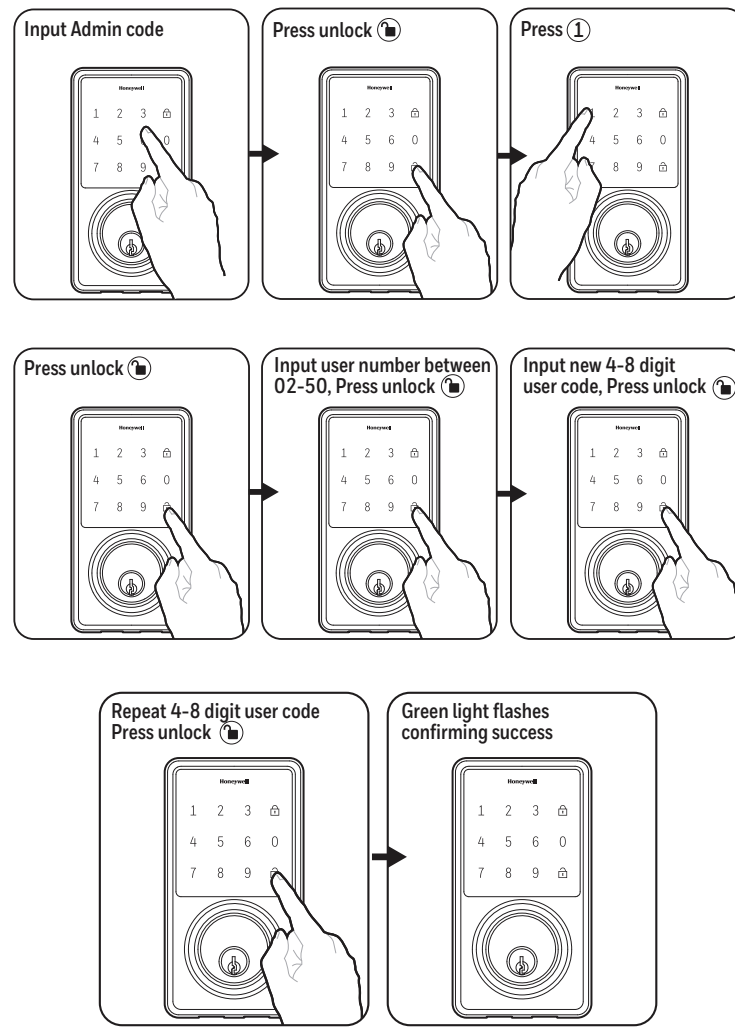

## 3 Unlocking Door with User Code

Touch screen to wake up lock.

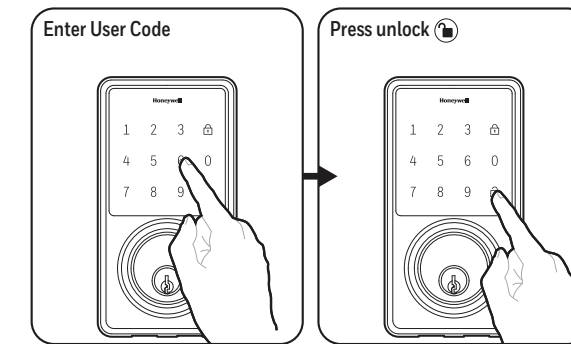

TO LOCK DOOR, wake up lock and press Lock button

### PROGRAMMING RECORD

My Codes:	Date Created
Programming Code	____ (6 digits) / /
User Code 02	____ (4-8 digits) / /
User Code 03	____ (4-8 digits) / /
User Code 04	____ (4-8 digits) / /
User Code 05	____ (4-8 digits) / /
User Code 06	____ (4-8 digits) / /
User Code 07	____ (4-8 digits) / /
User Code 08	____ (4-8 digits) / /
User Code 09	____ (4-8 digits) / /
User Code 10	____ (4-8 digits) / /
User Code 11	____ (4-8 digits) / /
User Code 12	____ (4-8 digits) / /
User Code 13	____ (4-8 digits) / /
User Code 14	____ (4-8 digits) / /
User Code 15	____ (4-8 digits) / /
User Code 16	____ (4-8 digits) / /
User Code 17	____ (4-8 digits) / /
User Code 18	____ (4-8 digits) / /

## 4 Deleting a User Code

Touch screen to wake up lock.

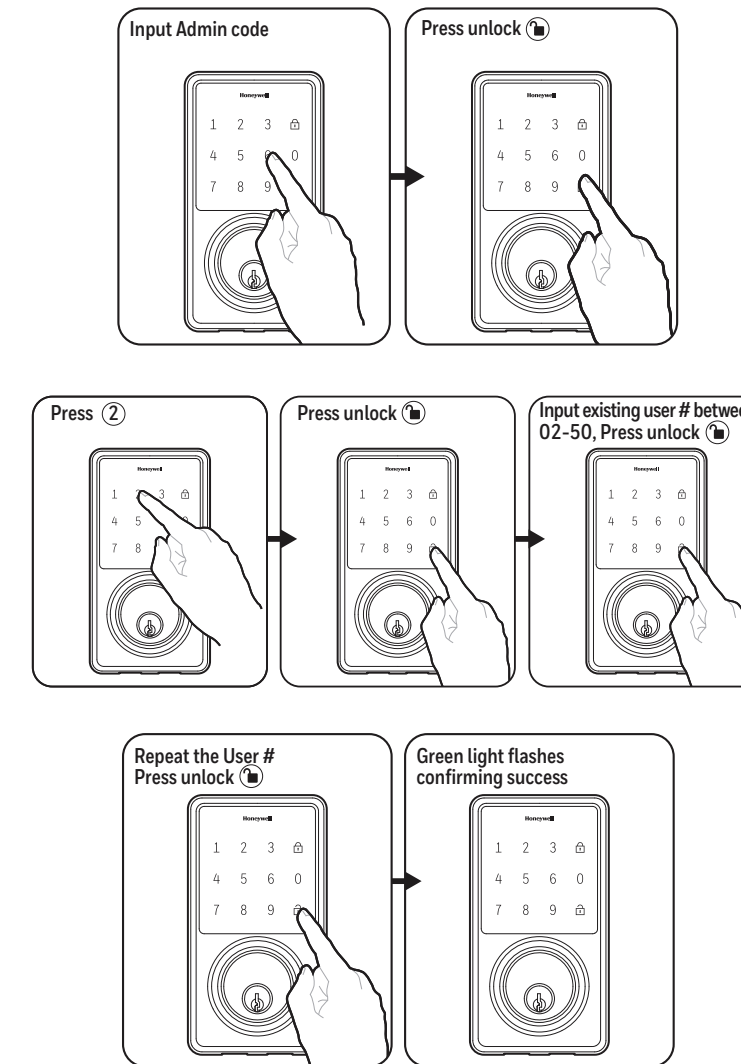

## 5 Deleting All User Codes

Touch screen to wake up lock.

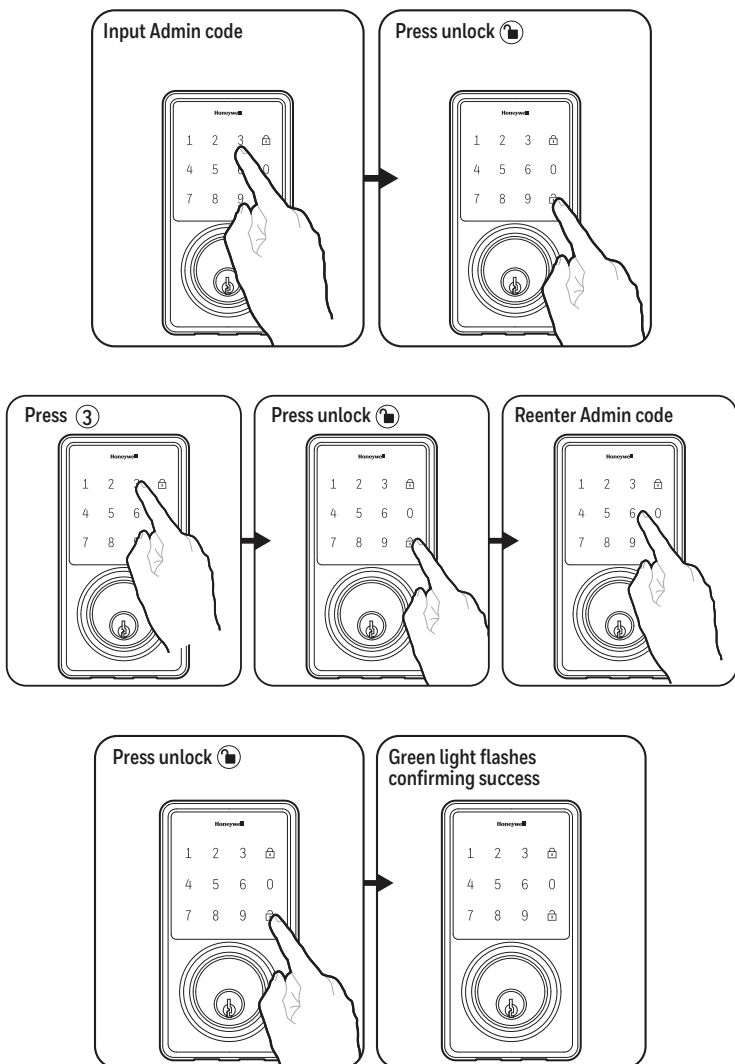

## 6 Additional Programming Functions

Touch screen to wake up lock. Wake up lock before each function.

### Programming Symbols

- ☒ Lock / Clear
- ☒ Unlock / Programming
- ☒ Administrator Code

### Automatic Lock Function

#### SET OR CANCEL AUTO LOCK

You can set the lock to automatically close after each time the lock is opened. Time value range = 20 - 900 seconds, enter the following:  
Set Auto Lock: ☒ ☒ ☒ → ☒ → 5 → ☒ → Time Value → ☒

Hear 1 beep and Light Indicator illuminates green.

To cancel Auto Lock set the time to 00, enter the following:

Cancel Time Value Auto Lock: ☒ ☒ ☒ → ☒ → 5 → ☒ → 00 → ☒

Hear 1 beep and Light Indicator illuminates green.

#### TEMPORARILY DISABLE:

While in Auto-Lock mode, unlock door using ☒. Immediately turn the locking knob back to the unlocked position. You will hear 1 beep and the light indicator will illuminate green. The Auto-Lock mode is now disabled.

#### RESTORE:

To restore the Auto-Lock function, turn the locking knob by hand to the locked position, wait more than 2 seconds or press the Lock button on the touchscreen.

#### Vacation Mode

With Vacation Mode enabled, the system enters into low-power consumption mode. During this mode, all buttons and functions will be disabled until they are re-enabled.

#### ENABLE:

☒ ☒ ☒ → ☒ → 10 → ☒ → 1 → ☒ light indicator illuminates green.

Once the door is locked, vacation mode will be engaged and all buttons and functions will be disabled.

#### DISABLE:

To disable the Vacation Mode, you must press and hold unlock for more than 3 seconds, then input ☒ followed by unlock to unlock the door. The light indicator will illuminate red. Vacation Mode is now disabled.

**⚠ NOTE: If you only press unlock for more than 3 seconds but do not input ☒, the system will remain in Vacation Mode.**

### Secure Lock-out period

Warning sounds and LED flashes red after 4 incorrect code attempts: Touchscreen shuts down for 60 seconds.

## 7 Additional Programming Functions

### SOUND ON AND OFF

You can "mute" or turn the "sound on" on your lock by entering the following. (Factory setting is sound on).

☒ ☒ → ☒ ☒ → 6 → ☒ ☒ → 1 or 2 → ☒ ☒

1 = Sound Off  
2 = Sound On

Sound Off (1) - Light Indicator illuminates green.

Sound On (2) - Hear 1 beep and Light Indicator illuminates green.

### Restore Factory Settings

To reset the lock to the original factory settings including the Programming Code and all User Codes follow these steps:

1. Remove one battery for 10 seconds.
2. Reinsert the battery and wait for a long and short beep
3. Press Lock button 3 times within 3 seconds.
4. The lock will beep and the light indicator will turn green.

### Low Battery Warning

Beeps and LED flashes red 7 times. Replace with good quality alkaline batteries.

**Note:** Removing batteries does not erase active Administrator or User Codes.

### Consumer Friendly Message Guide

Unlock / Valid programming:	1 long beep and LED illuminates green
Lock:	2 short beeps and LED illuminates red
Invalid Programming:	2 short beeps and LED flashes red twice
Low Voltage:	Short beeps and LED flashes red seven times
Super Low Voltage:	4 short beeps and LED flashes red four times
4 Incorrect code entry attempts:	2 short beeps and LED illuminates red each attempt
Power on:	1 long beep and 1 short beep and LED illuminates green
Chip Reset:	1 long beep and 1 short beep and LED illuminates green (may occur several times or once in a while)
Lock Error:	3 long beeps LED flashes red three times
Repeat operation after Lock Error:	2 short beeps three times LED flashes red six times

## Troubleshooting

Issue	Solution
Interior Knob will not turn	Knob or vertical tailpiece is installed in incorrect position. • Remove Interior Assembly and reposition the Interior Knob. With the Deadbolt Latch retracted verify that the tailpiece is vertical.
Lock will not function electronically	• Check that all batteries are fresh high quality Alkaline Batteries. • Check for proper polarity (+ -) of all batteries. • Check that the Control Wire is attached to the Interior Assembly and not damaged. • Check each wire for loose or disconnected wires. • Disconnect the wiring harness and reconnect the wiring harness.
Lock gives error signal when opening or locking and Deadbolt Latch will not extend or retract completely when door is closed	• Unlock door using Key or Interior Knob. While door is open, check that the Deadbolt Latch operates smoothly. • Check for proper alignment of the strike plate, adjust as needed to assure there is no binding against the Deadbolt Latch. • Make sure tail piece is in the vertical position and straight up and down.
Deadbolt Latch is sticking	Installation screws of the lock may be too tight and have to be loosened. • Remove Interior Assembly. • Slightly loosen the Mounting Plate screws. • Lock and unlock using the Key. • Reattach Control Wire and Interior Assembly.
Touchscreen not working	• Wait 60 seconds, touchscreen may be locked out due to incorrect code. • Replace with 4 high quality alkaline batteries.
Touchscreen beeps and LED flashes	• Replace with 4 high quality alkaline batteries.

### DO NOT RETURN TO STORE!

Problems Installing or Using this Product?

Call Us First!

Contact Us 1-800-860-1677 Ext. 1801

locks@LHLPL.com

Support hours M-F 8am - 8pm EST

### CONSUMER ASSISTANCE

EMAIL: LHLPLCustomerService@LHLPL.com WEBSITE: www.honeywellsafes.com  
ADDRESS: Consumer Assistance Dept. LH Licensed Products, Inc., 860 East Sandhill Avenue Carson, CA 90746 USA  
TELEPHONE: US/Canada 1-800-860-1677 Ext. 1801 (Toll Free)

Mexico 01-800-288-2872 After English voice recording stops you must then enter 800-860-1677 to complete your call. (Toll Free)

Australia 0011-800-5325-7000 (Toll Free)

Germany/New Zealand 00-800-5325-7000 (Toll Free)

Other Countries XX-310-323-5722 (Toll Charges Apply)

XX- Dial US Country Code first

CALL CENTER HOURS: US/Canada 8am - 5pm (Pacific\*\*) Mon - Fri

(Subject to change)

CALL BACK HOURS: Other Countries 8am - 5pm (Pacific\*\*) Mon - Fri

(Subject to change)

Pacific\*\* - Local time in Los Angeles, CA, USA

\* Insert correct Country Code

\*\* Local Time based on Los Angeles California USA

INTERNATIONAL CALL BACK HOURS:

If you need to speak with a consumer assistant and cannot contact us during the Call Center hours above, please send an email or leave a telephone message, including your Name, Telephone Number and the best time for us to contact you during the Call Back hours above and we will make our every effort to contact you and help answer any of your questions or concerns.

### Limited Lifetime Mechanical and Finish Warranty / 1 Year Limited Electronics Warranty

This product comes with a limited lifetime mechanical and finish warranty and a one year limited electronics warranty to the original residential consumer against defects in material and workmanship under normal use as long as the original residential purchaser occupies the residential premises upon which the product was originally installed.

#### ORIGINAL RESIDENTIAL CONSUMER

This warranty is not transferable, and applies to the original purchaser only, as long as the original purchaser occupies the residential premises upon which the product(s) was originally installed. Proof of purchase (original sales receipt) and ownership must accompany all warranty claims. All non-homeowner purchasers (including purchasers for industrial, commercial and business use) are not covered under the terms of this warranty.

#### WHAT IS NOT COVERED

This warranty is null and void if the product was used for purposes for which it was not designed. This warranty DOES NOT COVER normal wear and tear of parts or damage resulting from any of the following: negligent use, misuse or abuse of the product, or use contrary to or in violation of written instructions provided by LH Licensed Products, Inc. Further, this warranty does not cover Acts of God, such as fire, flood, hurricanes and tornadoes. This warranty DOES NOT COVER scratches, abrasions, deterioration due to the use of paints, solvents or use of cleaners containing abrasives, alcohol or other solvents, whether performed by a contractor, service company, or yourself. This warranty DOES NOT COVER product(s) used in commercial applications, used in common area applications, disassembly, repair or alteration by anyone other than LH Licensed Products, Inc., improper installation or exposure to extremes of heat or humidity. This warranty DOES NOT COVER any losses, injuries to persons or loss of property, general damages or costs, and shipping and freight expenses required to return product(s) to LH Licensed Products, Inc. LH Licensed Products, Inc. shall not be liable for any indirect, incidental or consequential damages of any nature relating to this lock. LH Licensed Products, Inc. is also not responsible for costs associated with removing or reinstalling the product.

#### ADDITIONAL TERMS

LH Licensed Products, Inc. does not authorize any person to create for it any obligation or liability in connection with the Product. LH Licensed Products, Inc.'s maximum liability here under is limited to the original purchase price of the Product. No action arising out of any claimed breach of this warranty by LH Licensed Products, Inc. may be brought by the original residential purchaser more than one (1) year after the cause of action has arisen.

#### AUSTRALIAN CONSUMER LAW

Our goods come with guarantees that cannot be excluded under the Australian Consumer Law. You are entitled to a replacement or refund for a major failure and for compensation for any other reasonably foreseeable loss or damage. You are also entitled to have the goods repaired or replaced if the goods fail to be of acceptable quality and the failure does not amount to a major failure.

Manufactured by:  
**LHLP** LH Licensed Products, Inc.  
860 East Sandhill Avenue  
Carson, CA 90746

The Honeywell Trademark is used under license from Honeywell International Inc. Honeywell International Inc. makes no representations or warranties with respect to this product.  
www.honeywellsafes.com

M8733500 EVO