

User Guide

Waterproof Fire Chest

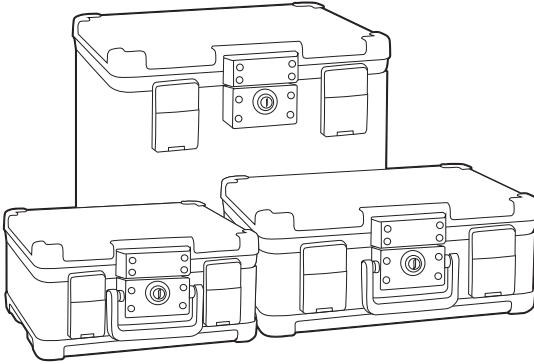

Models 1101, 1102, 1103,
1104 and 1108

Package Includes;

- 1 - Waterproof Fire Chest
- 1 - User Guide
- 2 - Entry Keys

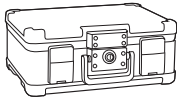

1 Waterproof Fire Chest

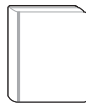

1 Operation
Manual

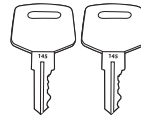

2 Entry Keys

Please carefully check the above list to confirm all items have been received. If any items are missing, please contact Consumer Assistance. (See page 9 for contact information).

Read this manual carefully and never store it inside the safe!

DO NOT RETURN CHEST TO STORE

If you are missing parts or have difficulty operating your Waterproof Fire Chest, please contact our Consumer Assistance Department by telephone. Store will not accept returned products without prior authorization. You must first contact our Consumer Assistance Department (See page 9 for contact information).

WATERPROOF FIRE CHEST IDENTIFICATION RECORD

Chest Model # _____

Chest Serial # _____

Access Key # _____

PRODUCT REGISTRATION

Please go to the following webpage to register your product:
www.hymaninc.com/product-registration/

INDEX

WELCOME / BEFORE USE / CARE AND MAINTENANCE	PAGE 3
PRODUCT OVERVIEW / HOW TO STORE CHEST	PAGE 4
UNLOCKING AND OPENING CHEST / ALWAYS OPEN LID COMPLETELY	PAGE 5
CLOSING AND LOCKING	PAGE 6
INTERIOR MOISTURE NOTICE / LOCATING KEY IDENTIFICATION NUMBERS.....	PAGE 7
PROPER USE.....	PAGE 8
CONSUMER ASSISTANCE.....	PAGE 9
ORDERING ADDITIONAL KEYS	PAGE 10
WARRANTY INFORMATION.....	PAGE 11

WELCOME

Your new Honeywell Fire and Water Chest will provide years of document and media protection. All Honeywell Fire and Water Chests are designed and built using the highest manufacturing standards to ensure maximum user satisfaction under a variety of conditions. Your Honeywell Fire and Water Chests will provide “Peace of Mind” for many years to come.

Thank you and enjoy!

BEFORE USE

IMPORTANT: BEFORE USING YOUR NEW CHEST

It should be opened and aired out for at least 30 minutes to allow the waterproof seal to decompress and perform as intended.



WARNING:

To avoid possible injury, make sure hands or fingers are clear before closing the chest lid.

CARE AND MAINTENANCE

When properly maintained, your Fire and Water Chest will continue to operate for many years. In order to ensure optimum performance of your chest, please follow these simple precautions:

CLEAN HANDS - Never attempt to operate the digital keypad if your hands have excessive dirt, debris or liquids on them.

CLEAN CASH BOX – To clean the surface of your Fire and Water Chest, it is recommended that you use a mild cleaner (e.g., window cleaner) to avoid scratching or discoloring the surface. Always wipe dry and NEVER use abrasive cleansers.

PRODUCT OVERVIEW

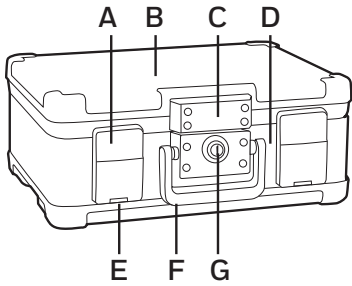

EXTERIOR

A - Compression Latches

B - Chest Lid

C - Lock Assembly

D - Chest Body

E - Latch Buttons (All Models except 1101)

F - Handle (All Models except 1106 & 1108)

G - Lock Cylinder

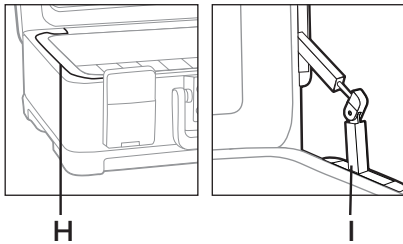

INTERIOR

H - Protective Waterproof Seal (All Models except 1101)

I - Hydraulic Hinge (1104 & 1108 ONLY)

HOW TO STORE CHEST

For your chest to perform as specified, it must always be stored flat with the lid on top. Never store the chest on any of the sides or upside-down.

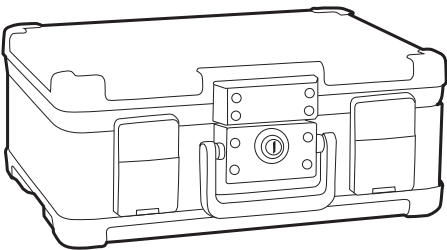

RIGHT

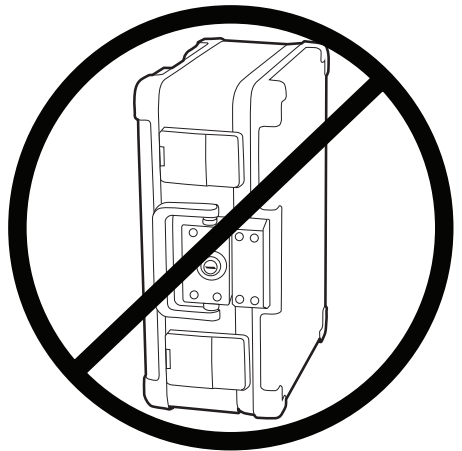

WRONG

UNLOCKING AND OPENING CHEST

1. Press in on small black piece at bottom of latches (Figure 1).
2. Insert key into lock cylinder (Figure 2).
3. Turn the key clockwise to the right $\frac{1}{4}$ turn (Figure 3).
4. Chest is now unlocked and you may lift the lid (Figure 4).

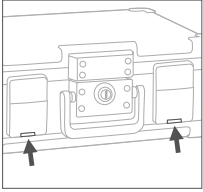

Figure 1

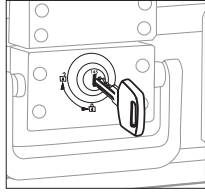

Figure 2

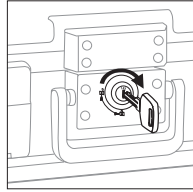

Figure 3

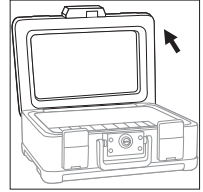

Figure 4



WARNING:

To avoid possible injury, make sure hands or fingers are clear before closing the chest lid.

ALWAYS OPEN LID COMPLETELY (1104 & 1108)

IMPORTANT:

To prevent possible injury when closing, models 1104 and 1108 are equipped with hydraulic hinges that will close the lid slowly.

Note: Always open the lid completely to activate the hinges (Figure 1).

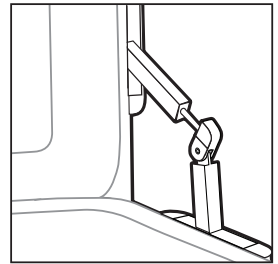

Figure 1



WARNING:

To avoid possible injury, make sure hands or fingers are clear before closing the chest lid.

CLOSING AND LOCKING (MODEL 1101)

1. Carefully lower lid into the closed position (Figure 1).
2. Insert key into lock cylinder (Figure 2).
3. Turn the key counter clockwise to the left $\frac{1}{4}$ turn (Figure 3).
4. Chest is now locked and you may remove the key.

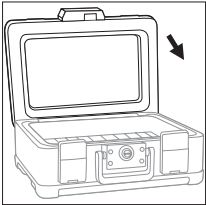

Figure 1

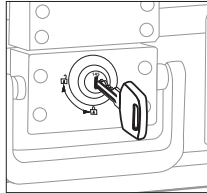

Figure 2

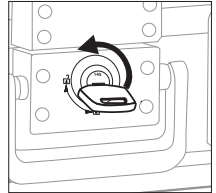

Figure 3

CLOSING AND LOCKING (ALL MODELS EXCEPT 1101)

1. Carefully lower lid into the closed position (Figure 1).
2. Press top of latch flat against chest and hold (Figure 2).
3. While holding top of latch in place, Press on bottom of the latch to lock into the closed position (Figure 3).
4. Turn the key counter clockwise to the left $\frac{1}{4}$ turn (Figure 4).
5. The chest is now locked and you may remove the key.

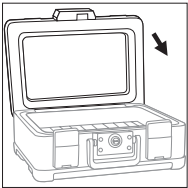

Figure 1

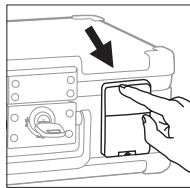

Figure 2

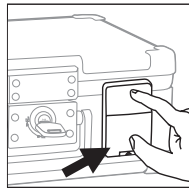

Figure 3

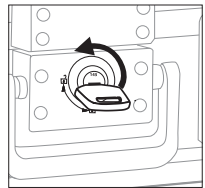
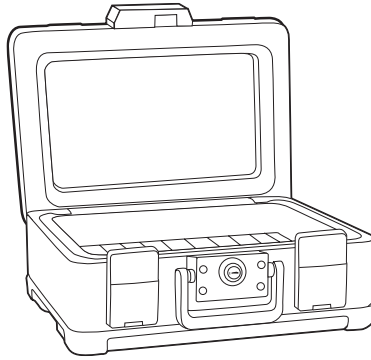

Figure 4

INTERIOR MOISTURE NOTICE

IMPORTANT - For optimum performance, Fire and Water Chests should be opened and aired out for at least 30 minutes every week to prevent any build up of moisture inside. It is recommended to occasionally do this for longer periods. This will balance the humidity difference inside and outside and allow any excess moisture trapped inside to escape. If you do not open Fire and Water Chests on a regular basis to let them air out, you may begin to notice a musty smell, especially on paperwork. The manufacturer will not be responsible for any damage or loss of items placed in Fire and Water Chests due to moisture. Proper care and preventative maintenance of Fire and Water Chests is the owner's responsibility. The owner should understand that this is required to assure continued levels of protection and trouble-free performance during the lifetime.



LOCATING KEY IDENTIFICATION NUMBERS

KEY NUMBER

3-4 Digit Number etched on the metal collar located around the key hole (Figure 1).

This same 3-4 Digit Number is also etched on the key itself (Figure 2).

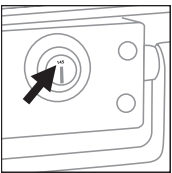

Figure 1

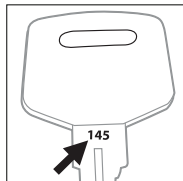

Figure 2

PROPER USE

Honeywell Chests are designed to protect paper documents and files from heat and moisture damage due to exposure to fire and water.

Warning: This chest is not intended for the storage of medications, firearms, ammunition, or combustible items of any kind.

You should not store pearls in this chest because they may sustain damage at temperatures below 350° F.

FIRE PROTECTION

Models 1101, 1102, 1103 & 1106 – Independent testing by Underwriters Laboratories (UL) verifies the interior temperature remains below 350° F (177°C) for 30 minutes when outside temperature is up to 1550°F (843°C).

Models 1104 & 1108 – Independent testing by Underwriters Laboratories (UL) verifies the interior temperature remains below 350° F (177°C) for at least 60 minutes when the outside temperature is up to 1700°F (927°C).

WATER PROTECTION

All Models except 1101 – Independent testing verifies that the interior remains dry when completely submerged for up 24 hours.

CONSUMER ASSISTANCE

EMAIL: LHLPCustomerService@LHLPinc.com

WEBSITE: www.honeywellsafes.com

ADDRESS: Consumer Assistance Dept.
LH Licensed Products, Inc.
860 East Sandhill Avenue
Carson, CA 90746 USA

TELEPHONE: US/Canada 1-877-354-5457 (Toll Free)
Mexico 01-800-288-2872 After English voice
recording stops you must then enter 800-860-1677
to complete your call. (Toll Free)Australia
0011-800-5325-7000 (Toll Free)
Germany/New Zealand 00-800-5325-7000 (Toll Free)
Other Countries XX*-310-323-5722 (Toll Charges Apply)
XX*- Dial U.S. Country Code first

CALL CENTER HOURS: US/Canada 7am - 5pm (PST**) Mon - Fri

CALL BACK HOURS: Other Countries 7am -8pm (PST**) Mon - Fri
PST**- Local time in Los Angeles, CA, USA

INTERNATIONAL CALL BACK HOURS:

If you need to speak with a consumer assistant and cannot contact us during the Call Center hours above, please send an email or leave a telephone message, including your Name, Telephone Number and the best time for us to contact you during the Call Back hours above and we will make every effort to contact you and help answer any of your questions or concerns.

* Insert correct Country Code

** Local Time based on Los Angeles California USA

ORDERING ADDITIONAL OVERRIDE ACCESS KEYS

The following information is required to obtain a Key:

1. PROOF OF OWNERSHIP (1 of 2 Options Below)

SALES RECEIPT & IDENTIFICATION - INTERNATIONAL ORDERS ONLY!

- Copy of sales receipt showing Store, Date & Product Description.
- Copy of your picture I.D. (Drivers license, passport, regular I.D.).

PRODUCT OWNERSHIP VERIFICATION FORM

If sales receipt is not available, contact us by email or telephone to request a "Product Ownership Verification Form".

2. CONTACT & PRODUCT INFORMATION

CONTACT INFORMATION

- Name & Mailing Address
- E-mail address (If Available)
- Telephone Number
- Best Time to Contact You

PRODUCT INFORMATION

- Cash Box Model #
- Cash Box Serial #

3. METHOD OF PAYMENT

- Telephone: Visa or MasterCard
- Mail: Check or Money Order

NOTE: For pricing please contact Consumer Assistance. Contact information is located on the back cover of this manual.

Terms subject to change without prior notification.

LIMITED WARRANTY

LH Licensed Products, Inc., (“LHLP, Inc.”) warrants that for a period of five (5) years from the date of purchase, this product will be free from structural or mechanical defects resulting from materials or workmanship. LHLP, Inc., at its sole option and as the purchaser’s sole remedy under this warranty, will repair or replace this product or any component of the product found to be defective during the warranty period. Replacement or repair will be made with a new or remanufactured product or component. If the product is no longer available, replacement may be made with a similar product of equal or greater value.

THIS IS YOUR EXCLUSIVE WARRANTY.

Our goods come with guarantees that cannot be excluded under the Australian Consumer Law. You are entitled to a replacement or refund for major failure and for compensation for any other reasonably foreseeable loss or damage. You are also entitled to have the goods repaired or replaced if the goods fail to be of acceptable quality and the failure does not amount to a major failure.

This warranty is only valid for the original retail purchaser from the date of initial retail purchase and is not transferable. You must keep the original sales receipt. Proof of purchase is required to obtain warranty service.

LHLP, Inc. dealers, service centers, or retail stores selling this product do not have the right to alter modify or in anyway change the terms and conditions of this warranty.

This warranty does not apply to the finish on the product. This warranty does not cover normal wear and tear of parts or damage resulting from any of the following: negligent use or misuse of the product, use contrary to the operating instructions, disassembly, repair or alteration by anyone other than LHLP, Inc. Or an authorized service center, improper installation, or exposure to extremes of heat or humidity. Further, the warranty does not cover Acts of God, such as fire, flood, earthquakes, hurricanes and tornadoes.

LHLP, Inc. shall not be liable for any incidental or consequential damages caused by the breach of any express or implied warranty or otherwise relating to the sale of this product. LHLP, Inc. is also not responsible for : costs associated with removing or installing the product; damage or loss of the contents of the product; nor for the unauthorized removal of the contents; or damages incurred during shipment.

THE ABOVE WARRANTY IS IN LIEU OF ALL OTHER WARRANTIES, EXPRESS OR IMPLIED, INCLUDING ANY WARRANTIES OF MERCHANTABILITY OF FITNESS FOR A PARTICULAR PURPOSE, AND LHLP, INC. DISCLAIMS ANY AND ALL OTHER COVENANTS AND WARRANTIES.

Except to the extent prohibited by applicable law, and implied warranty of merchantability or fitness for a particular purpose is limited in duration to the duration of the above warranty period. Some states, provinces or jurisdictions do not allow the exclusion or limitation of incidental or consequential damages or limitations on how long an implied warranty, lasts, so the above limitations or exclusion may not apply to you. This warranty gives you specific legal rights, and you may also have other rights that vary from state to state, or province to province, or jurisdiction to jurisdiction.

LIFETIME AFTER-FIRE REPLACEMENT GUARANTEE

If this Honeywell fire resistant product was purchased from LH Licensed Products, Inc. (“LHLP”) and is damaged by fire at any time while still owned by you (the original owner), LHLP will ship a free replacement if you send the following to Customer Service, LH Licensed Products, Inc., 860 E. Sandhill Ave., Carson, CA 90746 USA:

1. Your name, mailing address, email address, and phone number with area code;
2. A description of the fire, the model number and a photo of the burned unit, and a copy of the report from the fire department, insurance or police.

Freight on the replacement unit is not included in the guarantee and must be paid by the consumer. If an identical product is no longer available, LHLP will provide a similar unit from its current product line. LHLP is not responsible for any loss or damage to the contents of the safe.



Manufactured by:
LH Licensed Products, Inc.
860 East Sandhill Avenue
Carson, CA 90746

The Honeywell Trademark is used under license from Honeywell International Inc. Honeywell International Inc. makes no representations or warranties with respect to this product.