



DUO II ELECTRIC
SINGLE DESK
**ASSEMBLY AND
INSTRUCTION GUIDE**



TABLE OF CONTENTS

Assembly Instructions	3-6	
User Instructions	7-13	
Care and Maintenance	14	



Tools Required



Battery Drill

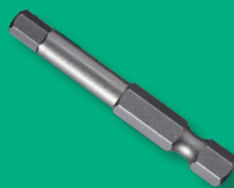

4mm Hex Bit

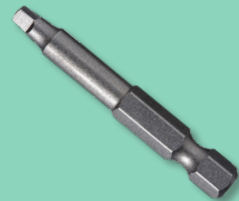

#2 Square Drive Bit

DUO II ELECTRIC SINGLE DESK

A. ASSEMBLY DIAGRAM

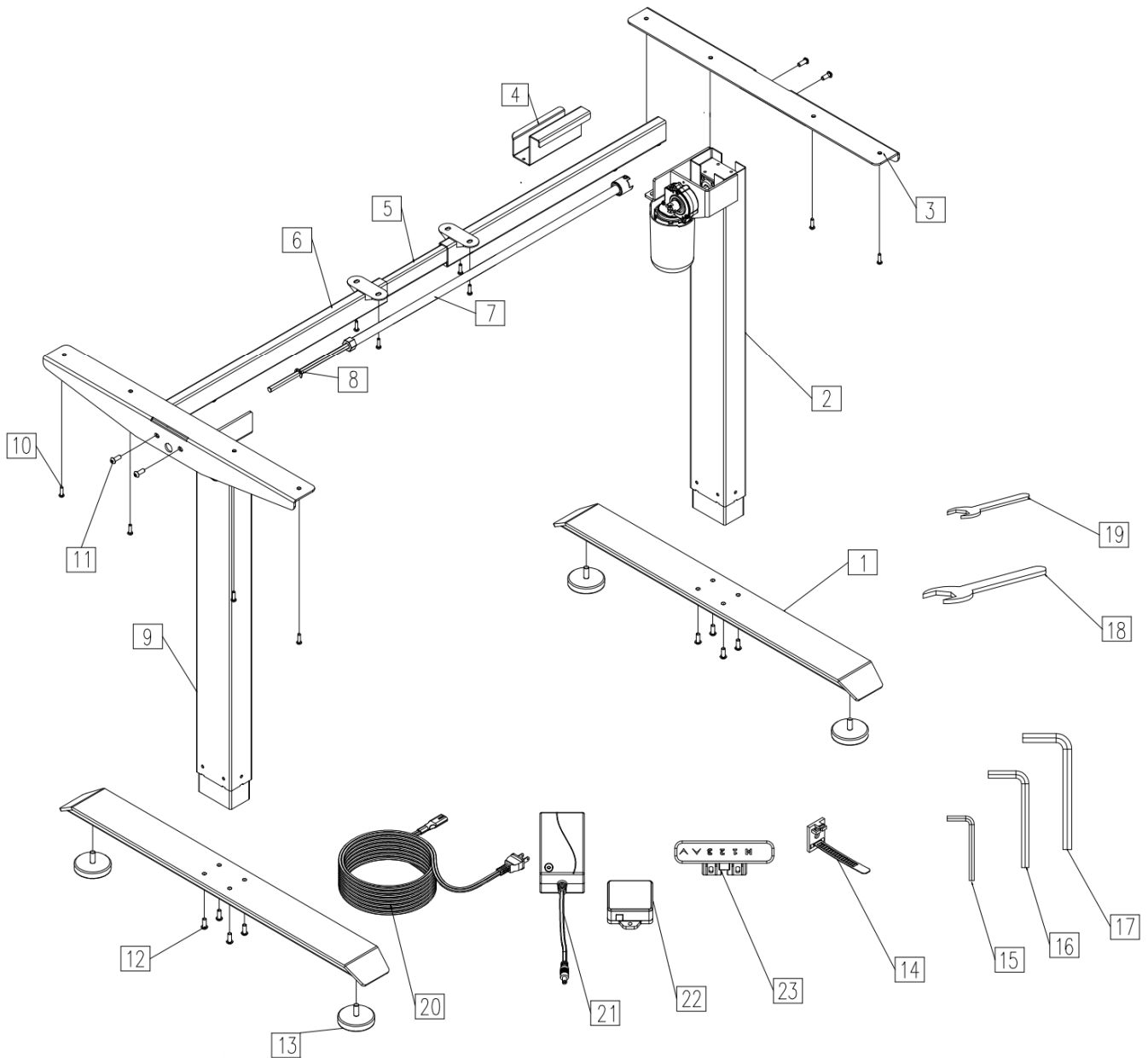

B. PACKING LIST

NO.	HARDWARE SECTION	QUANTITY
1	Foot	2pcs
2	Lifting Column (Motor)	1pc
3	Upper Side Support	2pcs
4	Steel Hanger	1pc
5	Extendable Tube	1pc
6	Framework	2pcs
7	Transmission Tube	1pc
8	Hex Bar	1pc
9	Lifting Column	1pc

	ACCESSORY PACKAGE	QUANTITY
10	Screw ST6x23	15pcs
11	Bolt M6x10	5pcs
12	Bolt M6x16	8pcs
13	Glide	4pcs
14	Cable Ties	2pcs
15	Hex Wrench-(2mm)	1pc
16	Hex Wrench-(4mm)	1pc
17	Hex Wrench-(8mm)	1pc
18	Spanner - I (8mm)	1pc
19	Spanner - II (18mm)	1pc

	CONTROL SECTION	QUANTITY
20	Power Cord	1pc
21	AC Adaptor	1pc
22	Control Box	1pc
23	Handset	1pc

C. HOW TO INSTALL THE DESK

STEP 1

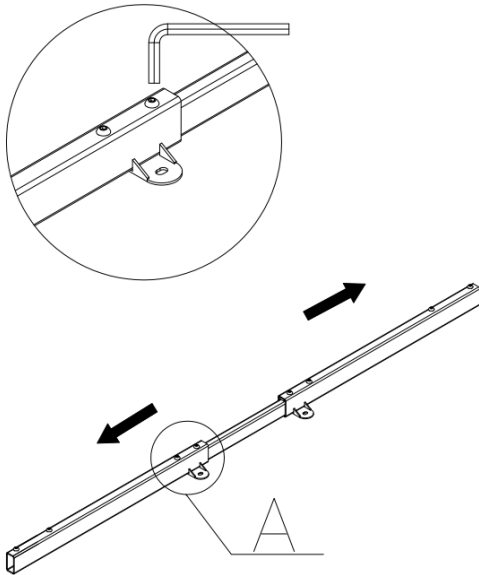

Take out the framework, release the M6x10 bolt with 4MM hex wrench.

STEP 2

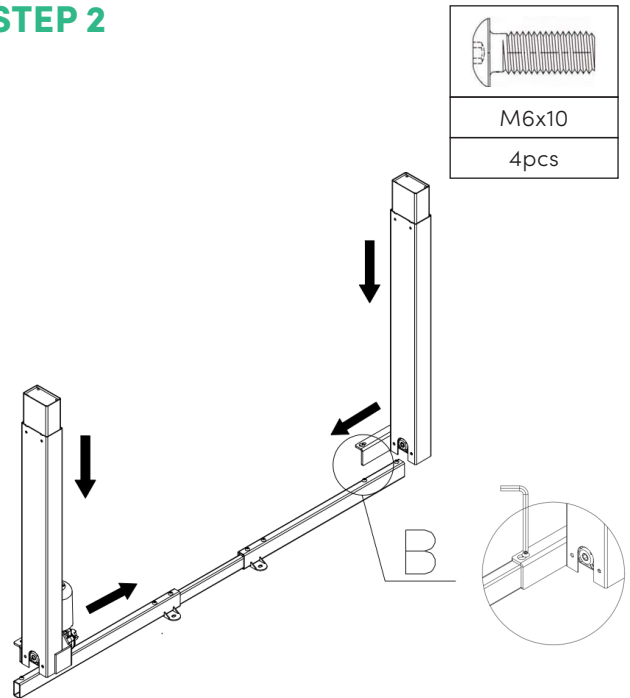

Install the lifting column, insert the screw into the keyhole of the lifting column and pull to one side, then fasten the M6x10 with a 4mm hex wrench.

STEP 3

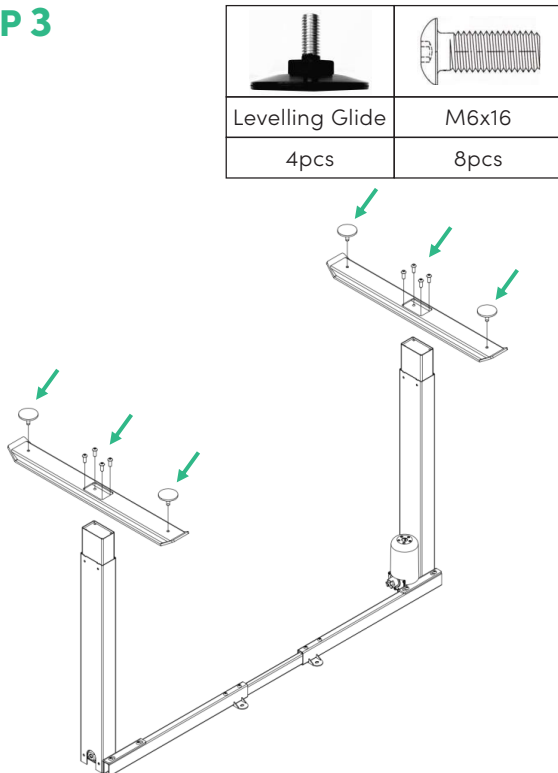

Install foot and levelling glides.

STEP 4

C STEP: 2.5 mm WRENCH

D STEP: Spanner

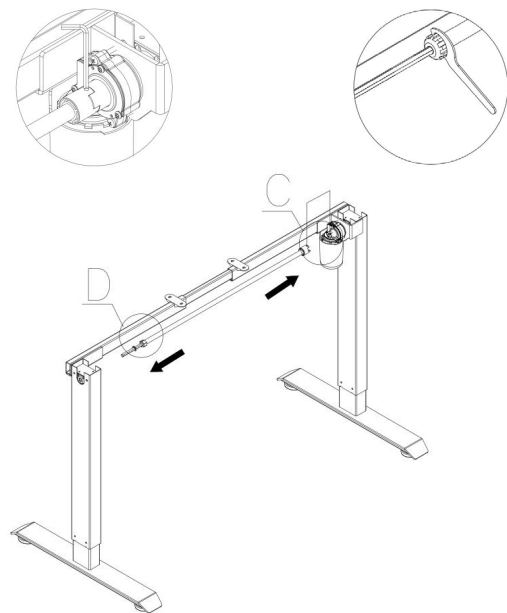

Insert hex bar and transmission tube with the help of spanner, and 2.5mm hex wrench.

STEP 5

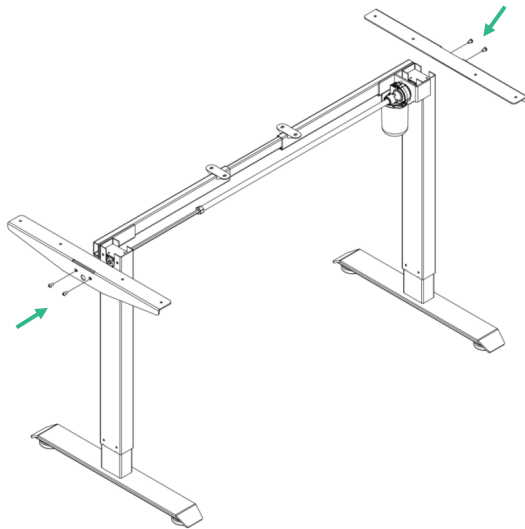
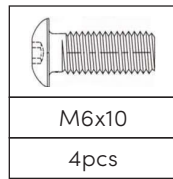

Install upper side support.

STEP 6

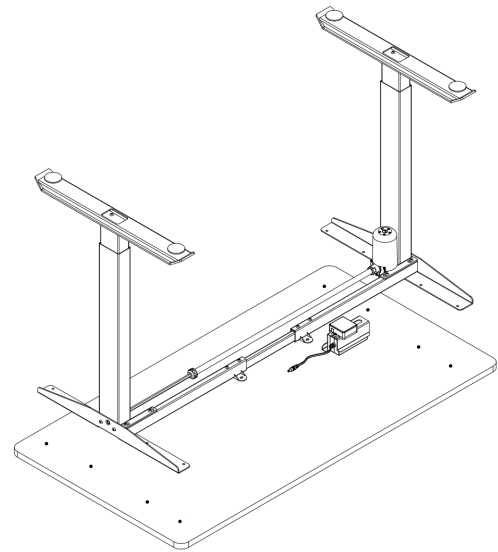

Our control box and AC adaptor are pre-fixed to the bracket, hang the bracket to frame and put on desktop.

STEP 7

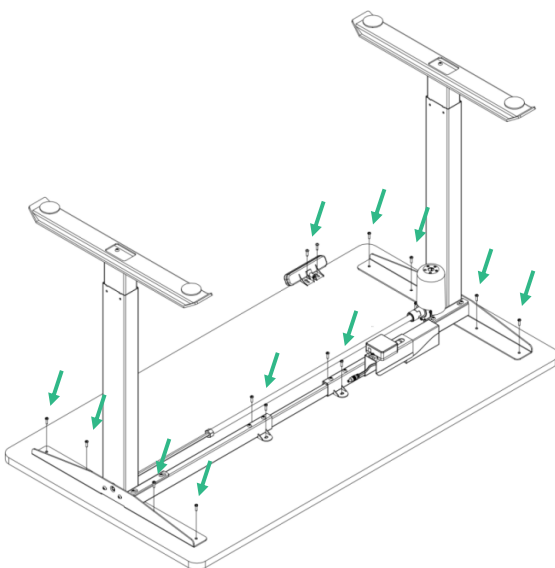
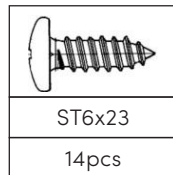

Install the desktop and handset.

STEP 8

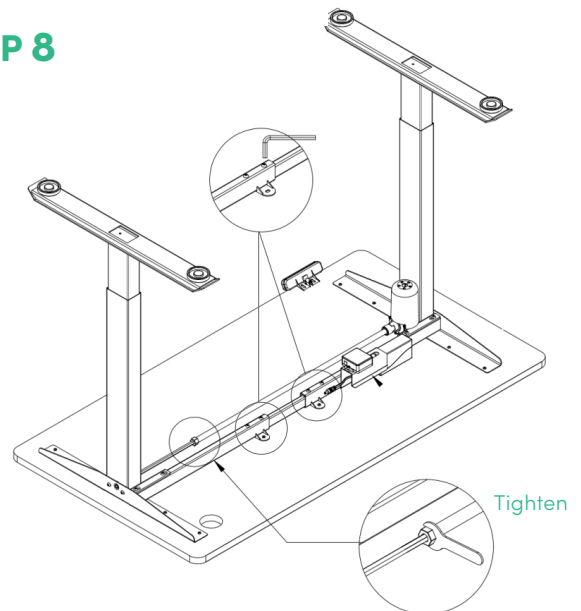

Check the Transmission tube is connected to both legs.

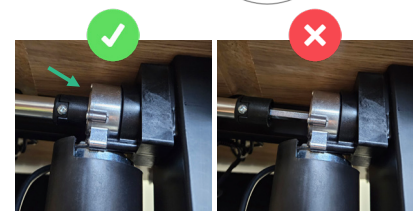

Tighten the bolt x4 (M6x10) and transmission tube.

Refer to page 9 on how to connect all the cords.

DUO II ELECTRIC SINGLE DESK USER INSTRUCTIONS

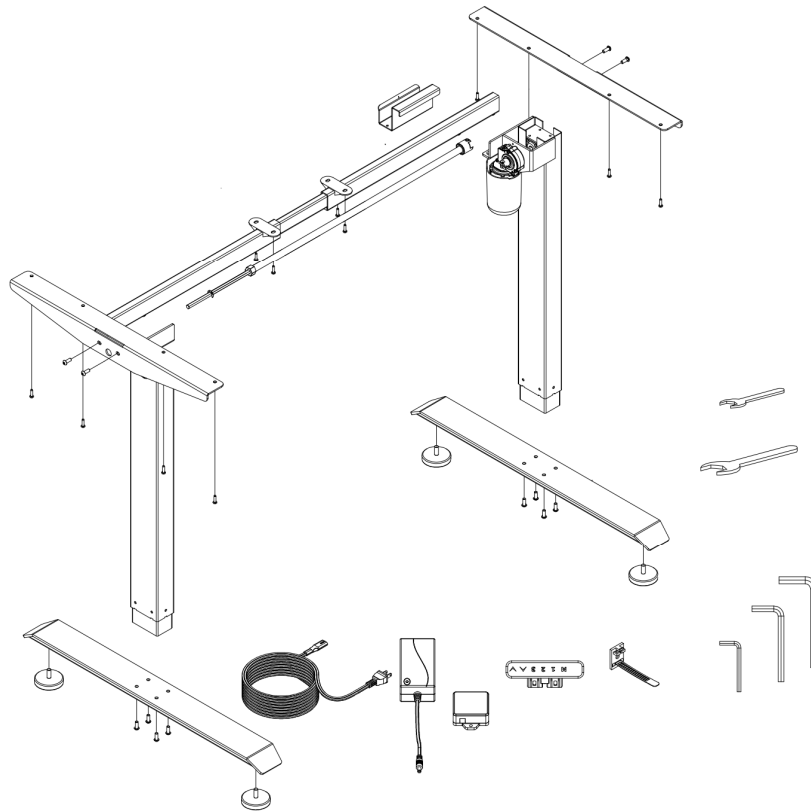

	SECTION	PAGE
Parts List	A	9
Technical Specifications	B	9
Directions of use	C	10
Trouble Shooting	D	10
Warranty	E	11
Changing between CM and Inch – 1UN	F	11
Setting Handset Display Brightness – 2BR	G	11
Adjust Upward Sensitivity – 3FU	H	12
Adjust Downward Sensitivity – 4FD	I	12
Adjust the Lowest Height Display and Height Range – 5SH	J	12
Switching Between Modes – 6HC	K	13
Adjust Bounce Height – 7H	L	13
Restore Factory Settings – 8R	M	13
Fatigue Test Mode – 9D	N	13
Handset Lock	O	14

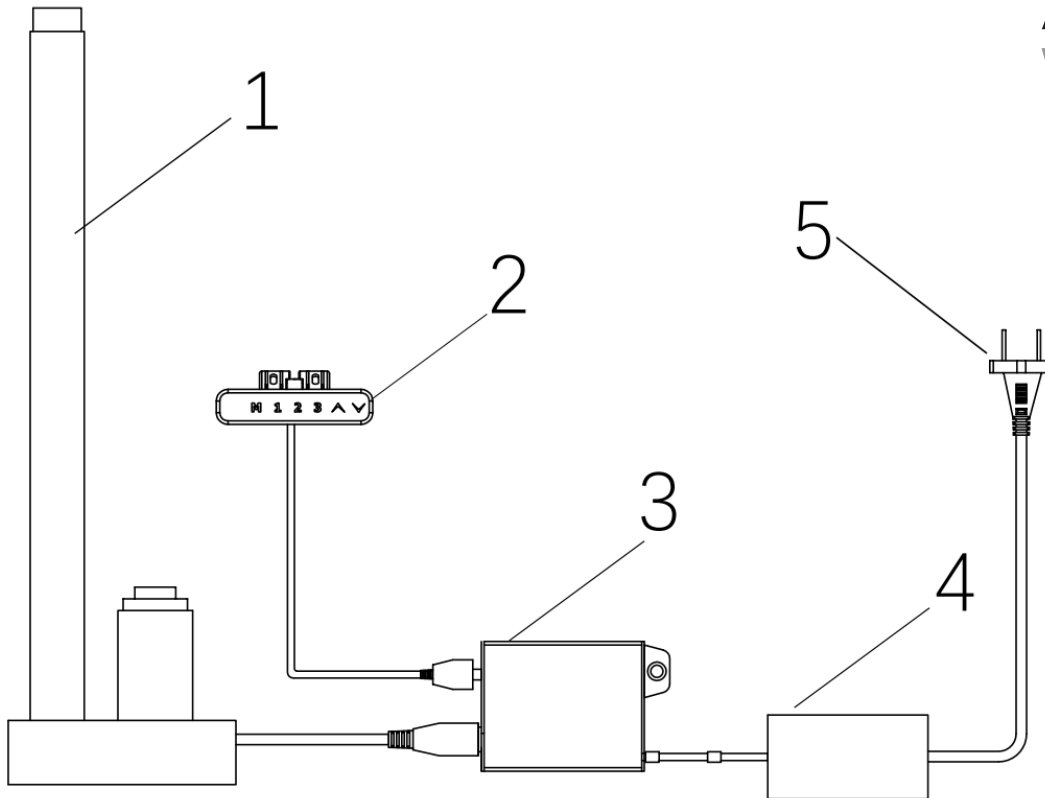

A. PARTS LIST

NO.	HARDWARE SECTION	QUANTITY
1	Lifting Column	2pcs
2	Handset	1pc
3	Control Box	1pc
4	AC Adaptor	1pc
5	Power Cord	1pc

B. TECHNICAL SPECIFICATIONS

NO.		
1	Input	110~240VAC
2	Output Power	24VDC
3	Load Capacity	800N
4	Speed	20mm/s
5	Stroke	450mm
6	Min Install Dimension	700mm
7	Operation Temperature	0-40°C
8	Duty Cycle	Max.22% or 5min on and 18min off

C. DIRECTION FOR USE

1. Correctly connect the Control Box, Handset, Power Cord, Lifting Column & Patch Cord. (Picture 1).

Plug the power cord into 110~220VAC outlet the LCD display will display will display current height.

Reset (Initialization):

Press and hold the down button, the handset will display "rES" and the desk will begin to lower, until to the lowest height then slightly rise. Continue holding the down button until the Handset displays the lowest height.

If the handset continues to display "rES" once the down button has been released, press and hold the down button until the Handset displays the lowest height.

3. After reset, press and hold "UP" button, lifting column will rise, release to stop.

4. After reset, press and hold "DOWN" button, lifting column will lower, release to stop.

Setting Memory Positions:

After pressing and holding UP/DOWN button to a height, press button M first, then press button 1, this height will be remembered by button 1.

Still pressing and holding UP/DOWN button to another height, press button M, then press button 2, this height will be remembered by button 2.

The same way, the button 3, 4 can remember other heights. After memory, press 1/2/3 button, desk will motion to the height it remembers, press "UP" and "DOWN" button. The motion will be stopped.

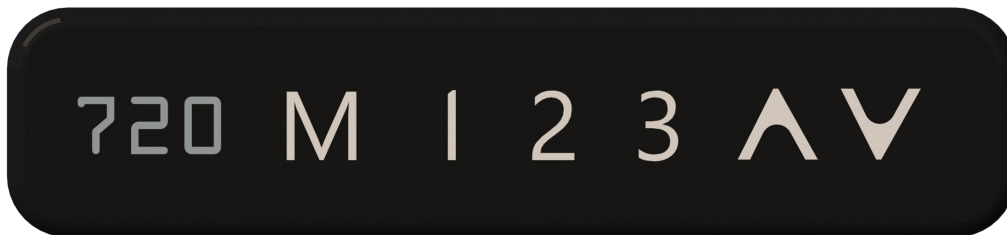

D. TROUBLE SHOOTING

If the LCD Controller displays error codes when raising or lowering the desk, a reset will be required.

1. Motor error (E01, E02 or E03, E04)

Control box cannot detect motor halt plate signal or Control box detect one lifting column is over loaded. This is a safety protection.

Please take away any large loads from the desk top and reset the controller. Should a reset fail to resolve the issue one or more motors will need to be replaced.

2. Control box temperature protection (HOT)

This indicates that the control box temperature is above 75°C or the system has been in continuous use for 2min or more. The lifting columns are locked out for up to 18mins as a safety precaution. For an urgent reset, unplug the power cord.

3. Overload protection (E07)

Desk load in excess of 100kg, user needs to reduce load, then reset or just need to wait for 3 seconds, it will recover.

4. Low Voltage protection (E08)

Power Voltage is too low for the controller, this is a safety cut out protection. System will recover as soon as voltage returns to normal.

5. High Voltage protection (E09)

Power Voltage is too high for the controller, this is a safety cut out protection. System will recover as soon as voltage returns to normal.

6. Control Box or Handset Issue (E10)

If Handset display E10 and will not disappear, control box or handset is broken.

E. WARRANTY NOTICE

1. This product must be used under the correct technical parameters.
2. Keep away from liquids, corrosives, gases and dusty environments.
3. Do not open any of the components, doing so will void any and all service support and manufactures warranties.



"1" Button - Return to previous menu

"UP" / "DOWN" Button - Select menu

"M" Button - Confirm menu

F. CHANGING BETWEEN CM AND INCH-1UN

Keep pressing Button "M" for 3 seconds, Handset will display "S---", then release pressing Button "M" and press Button "M" again, the code "1Un" will then appear.

Press Button "M" to enter.

1. It will display **Si**, you can press "M" button to preserve cm display and please wait for 2 seconds it will display current height(cm).

2. After it displays **Si**, you can press button "Up"/"Down" to change it to **i n**, press button "M" to preserve inch display and please wait for 2 seconds it will display current height(inch).

G. SETTING HANDSET DISPLAY BRIGHTNESS-2BR

1. Keep pressing button "M" for 3 seconds. Handset will display "S---", then release pressing button "M" and press button "M" again to enter, the code "1Un" will then appear.

2. Press button "Up"/"Down" to be **2br**.

Then press button "M" to enter, this will display current display brightness level (L/ **n** /H).

L: Means low brightness, **n**: Means normal brightness, H: Means high brightness.

3. Press button "Up"/"Down" to select your favorite brightness level, then press button "M" to preserve and quit, please wait for 2 seconds and it will display current height.

H. ADJUST UPWARD SENSITIVITY-3FU

1. Keep pressing Button "M" for 3 seconds. Handset will display "S---", then release pressing Button "M" and press Button "M" again to enter, the code "1Un" will then appear.

2. Press button "Up"/"Down" to be "3Fu". Then press button "M" to enter, this will display current upward sensitivity level (L5). We have 9 levels of upward sensitivity, from L1 to L9, L1 is the most sensitivity, L9 is the least sensitivity. L5 is our factory setting upward sensitivity.

3. Press button "Up"/"Down" to select your favorite upward sensitivity level, then press Button "M" to preserve and quit, please wait for 2 seconds and it will display current height.

I. ADJUST DOWNWARD SENSITIVITY-4FD

1. Keep pressing Button "M" for 3 seconds. Handset will display "S---", then release pressing Button "M" and press Button "M" again to enter, the code "1Un" will then appear.

2. Press button "Up"/"Down" to be "4Fd".

Then press button "M" to enter, this will display current upward sensitivity level (L5).

We have 9 levels of upward sensitivity, from L1 to L9, L1 is the most sensitivity, L9 is the least sensitivity. L5 is our factory setting upward sensitivity.

3. Press button "Up"/"Down" to select your favourite upward sensitivity level, then press button "M" to preserve and quit, please wait for 2 seconds and it will display current height.

J. ADJUST THE LOWEST HEIGHT DISPLAY AND HEIGHT RANGE-5SH

1. Keep pressing Button "M" for 3 seconds. Handset will display "S---", then release pressing Button "M" and press Button "M" again to enter, the code "1Un" will then appear.

2. Press button "Up"/"Down" to be "5SH", then press button "M" to enter, this will display $H_i b$, you also can press button "Up"/"Down", so that it will display $L_i L$ and $L_i H$.

$H_i b$: Mean to set the lowest position display height.

$L_i L$: Mean to set a new lowest position.

$L_i H$: Mean to set a new highest position

3. Press button "Up"/"Down" to be $H_i b$, then press button "M" to enter, will display current lowest height, you can press button "Up"/"Down" to adjust the lowest height display, then press button "M" to preserve and quit, please wait for 2 seconds and it will display new lowest height.

4. Press button "Up"/"Down" to be $L_i L$, then press button "M" to enter, will display current lowest height, you can press button "Up" set a new lowest position, then press button "M" to preserve and quit, please wait for 2 seconds and it will display height. New lowest position finished setting.

5. Press button "Up"/"Down" to be $L_i H$, then press button "M" to enter, will display current highest height, you can press button "Down" to set a new highest position, then press button "M" to preserve and quit, please wait for 2 seconds and it will display height. New highest position finished setting.

6. After setting, desk can only motion between new lowest position and new highest position.

K. SWITCHING BETWEEN MODES-6HC

1. Keep pressing Button “M” for 3 seconds. Handset will display “S---”, then release pressing button “M” and press button “M” again to enter, the code “1Un” will then appear.

2. Press button “Up”/“Down” to be “6Hc”, then press button “M” to enter, this will display current mode: “001”. You also can press button “Up”/“Down”, so that it will display “002”.

We have two modes for your choosing.

“001” mode: You need to keep pressing up or down button so that desk will motion.

“002” mode: You only need to press one time up or down button, the desk will motion, click press any button the motion will be stopped.

3. Press button “Up”/“Down” to select your favorite mode (001 or 002), then press button “M” to preserve and quit, please wait for 2 seconds and it will display current height.

L. ADJUST BOUNCE HEIGHT-7H

1. Keep pressing button “M” for 3 seconds. Handset will display “S---”, then release pressing button “M” and press button “M” again to enter, the code “1Un” will then appear.

2. Press button “Up”/“Down” to be “7H”, then press button “M” to enter, this will display current bounce height.

3. Press button “Up”/“Down” to set a favourite bounce height, then press button “M” to preserve and quit, please wait for 2 seconds and it will display current height.

M. RESTORE FACTORY SETTINGS-8R

1. Keep pressing button “M” for 3 seconds. Handset will display “S---”, then release pressing button “M” and press button “M” again to enter, the code “1Un” will then appear.

2. Press button “Up”/“Down” to be “8r”, press button “M” to enter, **Frt** will flash.

3. Press button “M” to preserve and quit, “rES” will appear, need a **reset** to finish restoring factory setting. (About reset, please refer to Step C)

N. FATIGUE TEST MODE-9D

1. Keep pressing button “M” for 3 seconds. Handset will display “S---”, then release pressing Button “M” and press button “M” again to enter, the code “1Un” will then appear.

2. Press button “Up”/“Down” to be “9d”, then press button “M” to enter. It will appear **Py_**, press 5 times button “1” continuously, you can enter into fatigue mode selecting menu. There will be 5 modes for your choosing.

OFF: No fatigue test.

51: Level 1 fatigue test, continue working, no stop.

52: Level 2 fatigue test, upward and downward 1 time then rest for 4 minutes.

53: Level 3 fatigue test, upward and downward 1 time then rest for 6 minutes.

54: Level 4 fatigue test, upward and downward 1 time then rest for 10 minutes.

3. Please press “up” and “down” to select your favorite fatigue mode, then press button “M” to preserve.
4. You can press “UP” button to begin fatigue test, also you can quit the fatigue test by unplugging the power cord.

O. HANDSET LOCK

1. Keep pressing “Up” and “Down” button for 5 seconds, handset will lock and **Loc** will flash.
2. Keep pressing “Up” and “Down” button for 5 seconds, handset will be unlock and handset will display current height.

FACTSHEET

CARE & MAINTENANCE

GENERAL CARE – INFORMATION

- Avoid scourers and abrasives as they will damage the surface.
- Don't place hot objects, electrical appliances or pots straight from the oven or cooker onto your laminate surface.
- Don't cut on the laminate surface.
- Keep waxes and polishes well away as they dull the natural shine.
- Do not use strongly acidic, alkaline cleaners or bleach for normal cleaning as these might etch the surface.

GENERAL CARE – STREAKS

Streaky marks sometimes show on dark colours after cleaning. An all-purpose cleaner such as Mr. Muscle Surface & Glass or Ajax Spray n Wipe usually removes them.

GENERAL CARE – GREASE

Using a mild dishwashing detergent in water will remove greasy marks. Dab, wait and wipe away. Finish with an all-purpose cleaner such as Mr. Muscle Surface & Glass or Ajax Spray n Wipe.

GENERAL CARE – SPILLS

Laminate surfaces resist staining from most household chemicals. With some accidental spills however, prompt action is essential. Wipe off beetroot, grape and berry juices, first aid preparations, concentrated bleach, oven cleaners, dishwasher detergents, artificial dyes, hair colouring and solvent based pen ink immediately. Specialty glues such as Super Glue must also be removed straight away with acetone (nail polish remover).

GENERAL CARE – STAINS

If the stain won't budge with Mr. Muscle Surface & Glass, try methylated spirits or dab the stain with a diluted bleach mixture (1 part bleach to 8 parts water); leave for 3 minutes then wash off with water and dry. Finish off with Mr. Muscle Surface & Glass. Only as a last resort if a stain persists try 2 or 3 rubs with a crème cleanser or white toothpaste, wash and dry. Please note that bleach or these abrasive cleaners may irreversibly damage the laminate surface.

GENERAL CARE – SCRATCHES

Laminate surfaces will withstand normal wear and tear, but can be damaged by scratching or cutting with utensils, knives and unglazed pottery. Darker colours will show scratches more readily than lighter colours. In general, dark colours and high gloss surfaces require more care and maintenance than lighter colours or lower gloss colours. To minimise scratching, always place and lift objects from the surface – never drag or slide them across the surface.

Accent

WARRANTY

REGISTRATION

At Accent Group, we are committed to delivering not only exceptional products but also exceptional customer experiences. We take immense pride in crafting each item with the utmost care to meet your expectations and your purchase is backed by our 15-year Warranty (terms and conditions apply). To make the most of this extended warranty and to facilitate any future claims seamlessly, we kindly request you to complete our Warranty Registration Form by scanning the QR code below. Providing us with your details will enable us to serve you better and ensure your peace of mind throughout the warranty period.

View full Warranty details on our website – www.accentgroup.co.nz

CUSTOMER PRODUCT REVIEW TEAM

As a company committed to excellence, we continuously seek ways to enhance our offerings and deliver the finest in the NZ market. We invite you to take part in a Customer Product Review. Your valuable feedback matters to us, and joining the team is effortless. Approximately three months after your product delivery, one of our team members will reach out to you for a brief call. During this conversation, we will enquire about your product experience. Your insights on what's working well and what's not, whether the products have met your expectations, and if you would consider purchasing from Accent again are highly appreciated.

By joining our Customer Product Review Team, you play an integral role in shaping the future of our products, ensuring they align perfectly with your needs and preferences. Your voice will guide us in crafting even better offerings that resonate with customers like you.

We are truly excited about this opportunity to collaborate with you closely.

If you wish to participate in the program, please tick YES when you complete your Warranty Registration. Every quarter we'll select 4-5 customers to take part in the 3 month product review each customer we receive feedback from will receive a \$50 Prezzy card.

Don't hesitate to reach out to us if you have any queries or need assistance, give our team a call on 0800 826 126. Thank you again for choosing Accent Group products.

Best regards,
The Accent Group Team

Accent

SCAN TO REGISTER



0800 126 826 | support@accentworkspaces.co.nz

15



0800 126 826

support@accentworkspaces.co.nz

22 Hood Street Wellsford, Auckland 0900 New Zealand