

Smart Plus True HEPA Air Purifier

Model: AV-P500



This user manual provides safety and operating instructions.
Please read this user manual thoroughly before using the product.

TABLE OF CONTENTS

Important Safety Instructions	4
Introduction	5
Getting to Know Your Air Purifier	6
Before Using For The First Time	7
General Tips	8
Operation	9
Replacing The Filter	12
Cleaning & Care, Storage, Disposal	15
Troubleshooting	16
Warranty Information	17
Customer Support - Australia	21

PACKAGE CONTENTS

- 1 x AV-P500 Smart Plus True HEPA Air Purifier
- 1 x Filter Package (Pre-installed in Air Purifier)
- 1 x User Manual
- 1 x Warranty Card

PRODUCT SPECIFICATIONS

Power Supply	220 - 240 V , 50 Hz
Rated Power	38 W
Effective Range	Areas up to 50 m ²
Operating Conditions	Temperature: -10 °C To 40 °C Humidity: < 85% RH
Noise Level	29 - 58 dB
Standby Power	< 0.5 W
Weight	3.7 kg
Dimensions	ø 23.5 × H50.0 cm
CADR (smoke)	230 m ³ /h
Filter Pack	3-Stage Filtration System: 1. Preliminary Filter 2. Korean H13 True HEPA 3. Activated Carbon Filter

THANK YOU FOR CHOOSING TO BUY AN AROVEC AIR PURIFIER

We are here to help you with any questions.
Customer Support - AUSTRALIA

- 🌐 www.rovec.com.au
- ✉ support@rovec.com.au
- 📱 @roveclifestyle

IMPORTANT SAFETY INSTRUCTIONS

Please read all instructions before use to prevent the risk of injury, fire, electric shock or damage.

- **DO NOT** use the air purifier before removing the plastic packaging from the filter. It is a fire hazard to use your air purifier with the filter still inside its packaging.
- **DO NOT** use the air purifier if it has been dropped, damaged, left outside, dropped in water, or not working properly.
- **DO NOT** use the air purifier if the cord or plug looks damaged.
- **DO NOT** use the air purifier near gas appliances, fire places, stoves, candles, or heating devices.
- **DO NOT** use the air purifier in an area with insect repellents, burning incense, toxic fumes, flammable dust or oxygen tanks. Always leave at least 1.5 m of clear space from any oxygen being administered.
- **DO NOT** touch any part of the air purifier or its plug with wet hands.
- **DO NOT** run the power cord under furniture, other appliances, carpet, or cover with rugs, runners or floor coverings.
- **ALWAYS** tuck away the power cord to prevent tripping accidents.
- **DO NOT** put the air purifier on an unstable surface e.g. bed or couch.
- **DO NOT** use the air purifier and power plug on wet or damp surfaces.
- **DO NOT** put the air purifier in water or liquids.
- **DO NOT** keep air purifier under an air conditioner to help prevent moisture getting into the unit.
- **DO NOT** use the air purifier outdoor.
- **DO NOT** use the air purifier in a room that can have a big change in temperature. This will help minimise the risk of condensation.
- **DO NOT** put fingers or any objects into the air inlet/outlet of the air purifier.
- **DO NOT** use a defective air purifier or attempt to repair/adjust any electrical or mechanical functions, this may cause danger and void the warranty.
- **DO NOT** let children or people with reduced physical or mental capabilities to use or clean the air purifier.
- **DO NOT** let children play with this appliance or its packaging including plastic bag. Children must be supervised around the air purifier to help keep them safe.
- **DO NOT** sit on the air purifier or put any objects on top of the unit.
- **DO NOT** block/obscure the air inlet or outlet. Keep free of anything that could reduce airflow.
- **DO NOT** spray air fresheners, perfumes or oils on or near the filter.
- **DO NOT** fit the air purifier with a different power supply unit.
- **DO NOT** clean the air purifier or change the filter with the power cord plugged in.
- **DO NOT** use the air purifier for commercial purposes. This appliance is for household use only.
- It is recommended to **NOT** use the unit with an extension cord to avoid electrical shock or spark.
- **TURN OFF** the air purifier when it is not being used. Hold the plug and remove it from the electrical source. Do not unplug by pulling the cable.
- **WARNING:** This air purifier does not remove carbon monoxide or radon from the air. It must not be used to prevent or clean up accidents with combustion processes and hazardous chemicals.

KEEP THESE INSTRUCTIONS IN A SAFE PLACE.

INTRODUCTION

The AV-P500 True HEPA air purifier removes contaminants from the air to improve indoor air quality. Be aware of the real-time air quality changes of your room with help of air quality sensor in the AV-P500.

Arovec AV-P500 air purifier uses a system of internal fan to pull the air in your room through a high efficiency filtration system that removes harmful airborne particles. Keep your environment healthy with AV-P500.

PRODUCT FEATURES

PM2.5 Value Display & Air Quality Indicator: This air purifier is equipped with an infrared dust sensor that is able to detect the amount of particles in a given space ($\mu\text{g}/\text{m}^3$).

PM2.5 refers to particulate matter (PM) that is less than or equal to 2.5 microns (μm) in diameter. The PM2.5 value and the air quality status in four different colours display on the screen to reflect the real-time air quality changes.

Smart Sensor & Auto-Mode: The smart air quality sensor in this air purifier intelligently detects PM2.5 levels and the purification speed automatically adjust accordingly in Auto-Mode to effectively deal with the pollution level.

Peaceful Sleep: Have an undisturbed deep sleep while the air purifier is quietly operating in Sleep-Mode. You can also turn off the display and light for a dark sleeping environment.

High Efficiency Filtration System: This air purifier contains multiple stage filtration system, which filters out 99.97% airborne harmful pollutants as small as $0.3 \mu\text{m}$ with 100% ozone free safe operation.

- 1. Preliminary Filter:** Captures large particles such as dust, pet dander and hair.
- 2. Korean H13 True HEPA Filter:** High grade H13 True HEPA Filter traps fine particles such as PM2.5, dust mites, allergens, airborne bacteria, pollen, mould and other airborne contaminants as small as $0.3 \mu\text{m}$.
- 3. High-Efficiency Activated Carbon Filter:** adsorbs various odours and smokes such as cigarette smoke, fumes, cooking smell, pet odours, hazardous gases and VOCs.

GETTING TO KNOW YOUR AIR PURIFIER

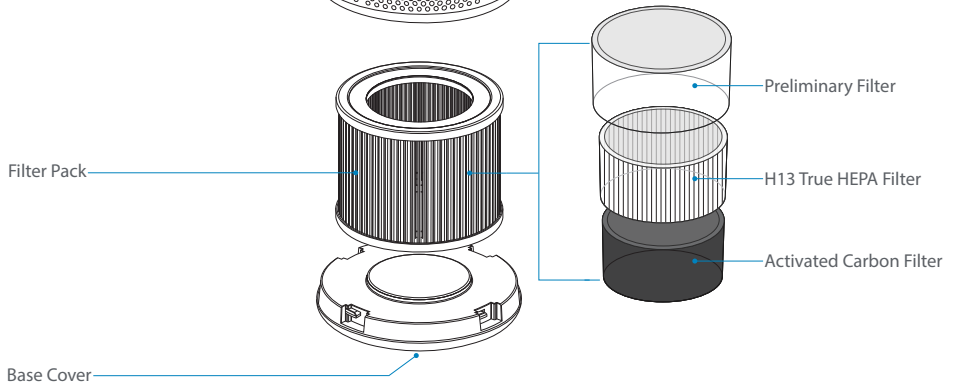
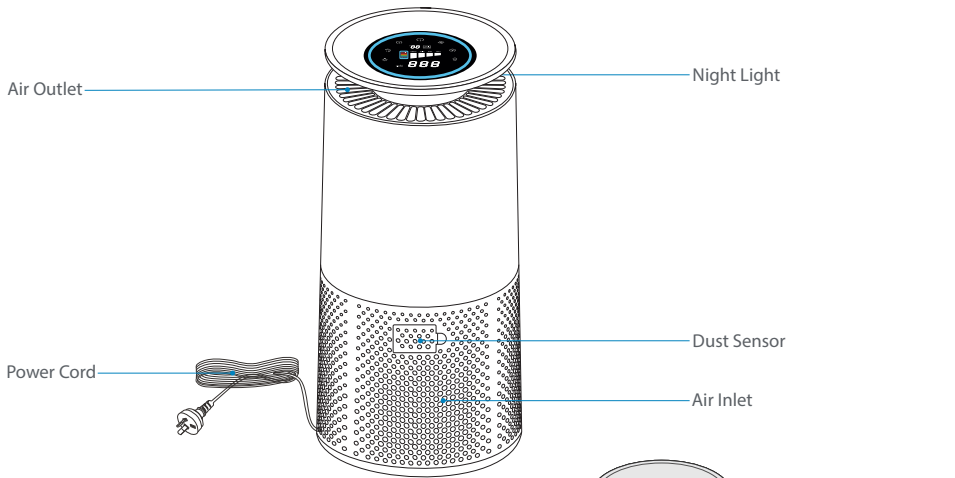
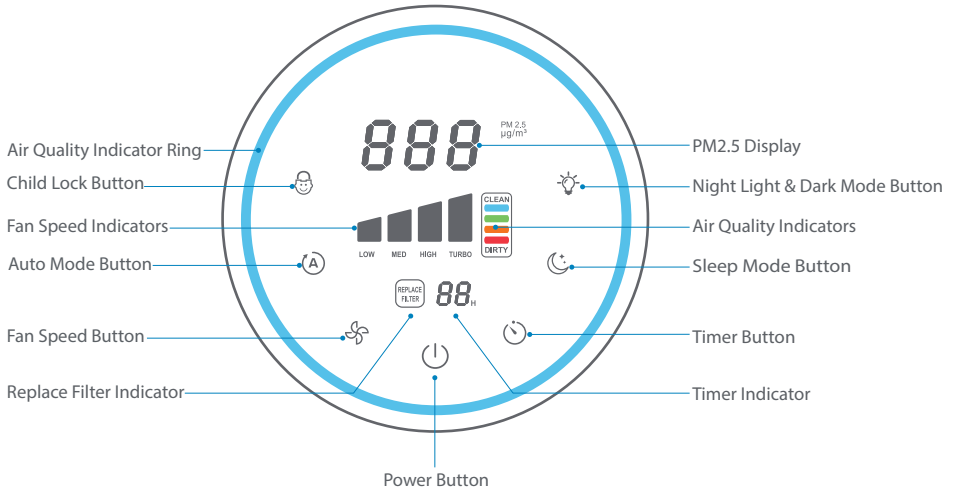

BEFORE USING FOR THE FIRST TIME

The air purifier comes with the filter fitted inside, but they are packaged in plastic. You must remove the filter from its packaging before turning the air purifier ON.

1. Place the air purifier on a stable surface in an upright position. Turn the base lock button to the left to unlock the base cover. [Figure 1.1]
2. Hold the air purifier and lift it up carefully. Remove the filter from the air purifier. [Figure 1.2]

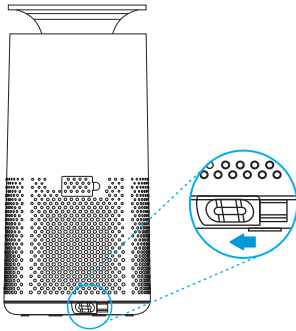

Figure 1.1

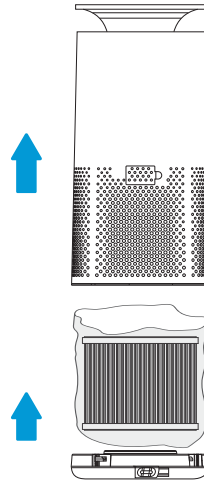

Figure 1.2

3. Remove the filter from its packaging. [Figure 1.3]

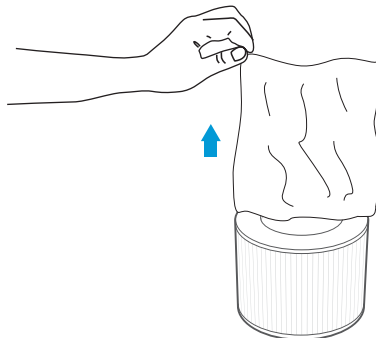

Figure 1.3

4. Put the filter back and set the air purifier on the base. [Figure 1.4]

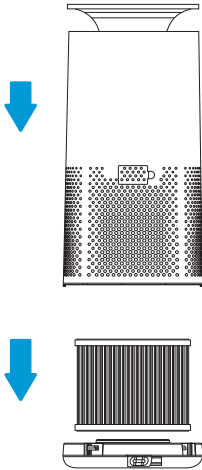

Figure 1.4

5. Turn the base lock button to the right to lock the base cover. [Figure 1.5]

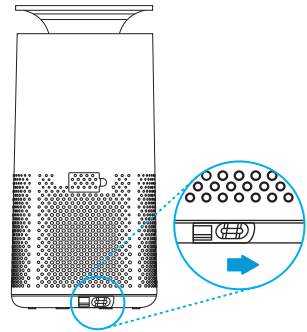

Figure 1.5

GENERAL TIPS

- The air purifier should be on a flat and level surface with the control panel facing up before switching it ON. [Figure 2.1]
- Leave at least 40 cm of clear space around each side of the purifier when it is ON. [Figure 2.1]

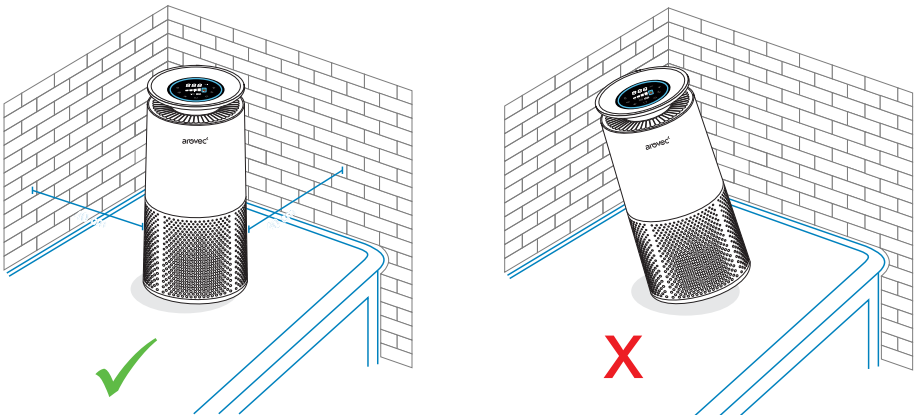

Figure 2.1

- Shut nearby windows when the air purifier is turned ON to help clean the air.
- For best results, use the air purifier for 15-20 minutes at the maximum fan speed, then adjust the fan speed as required.

OPERATION







888 PM 2.5 µg/m³

PM2.5 Value Display & Air Quality Indicator:

- PM2.5 refers to particulate matter (PM) that is less than or equal to 2.5 microns (μm) in diameter. The PM2.5 value on the display shows the amount of particles (μg) that are detected by the built-in dust sensor within 1 cubic meter (m^3).
- The air quality indicator changes its colour based on detected air quality as noted in [Table 1].

Table 1. Air Quality

*AQI Measured in PM2.5	Air Quality Status	Air Quality Indicator
< 35	Very Good	
35 – 66	Good	
67 – 100	Moderate	
> 100	Poor	

Note: It will take 1 minute for the dust sensor to detect the air quality after the air purifier turned ON.
*Air Quality Index



POWER Button:

- Tap () once to turn the air purifier ON or OFF.



FAN SPEED Button:



- There are 4 fan-speed levels: 1-LOW, 2-MED, 3-HIGH, and 4-TURBO.
- Each tap will toggle to the next fan speed level.
- Use the TURBO mode to purify the air quickly in an unusual event such as extreme smoke from a bushfire.





Memory Function:

- The air purifier keeps the control setting when it is turned OFF. When the air purifier is turned ON again, it will remember its previous fan setting.
- Please note that the air purifier must remain plugged-in for this memory function to work.



AUTO Mode Button:



- The () denotes for AUTO mode. Tap () to activate the AUTO mode.
- In AUTO mode the air quality indicator changes its colour based on detected air quality and fan speed adjusts accordingly. [Table 2]

Air Quality Indicator	Air Quality Status	Fan Speed
Blue 	Very Good	Low
Green 	Good	Med
Orange 	Moderate	High
Red 	Poor	Turbo

Note: It will take 1 minute for the dust sensor to detect the air quality after the air purifier turned ON.





CHILD-LOCK Button:

- In child-lock mode the control panel will deactivate.
- Press and hold () for 3-5 seconds to enter child-lock mode.
- Press and hold again () for 3-5 seconds to exit the child-lock mode and activate the control panel.







TIMER Button:

- You can set a timer for 1 to 12 hours.
- Tap () repeatedly to select a time.
- The timer display will automatically count down as time passes.
- The air purifier will automatically turn OFF once the timer has finished counting down.
- If no timer is set, the air purifier will continuously operate until it is manually turned OFF.
- To cancel the timer, tap () repeatedly until the timer display disappears.



SLEEP MODE Button:

- In sleep mode, the air purifier runs quietly on lowest fan speed and all indicators including lights will turn OFF, except ().
- Tap () to enter the sleep mode. The () will blink for 3 seconds, then the air purifier enters to the sleep mode.
- The () will change to deem-light (undisturbed) after 8 seconds.



NIGHT LIGHT & DARK MODE Button:

Night Light:

Single pressing Night Light button controls the LED night light and air quality ring light on the panel.

- The LED night light is in two colours (blue and orange).
- The air quality ring light displays in four colours depending on the air quality status (as explained on page 9).
- Tap () to select the light colour, controlling indicators' light and turn them OFF.
- Each tap will toggle to the next setting as explained below:

In default mode, all indicators including the air quality ring will be turned on. The night light stays off.

Tap 1, turns on night light (blue)

Tap 2, turns on night light (orange)

Tap 3, turns off night light and air quality indicator light (ring)

Tap 4, turns off all lights including indicators (Dark Mode)



Tap any key to exit Dark mode.

Dark Mode:

- Tap and hold () for 3-5 seconds to turn OFF all the display indicators and light. The air purifier will operate with zero light for no disturbance.



REPLACE FILTER Indicator:

- The () will light up to remind you to replace the filter.
- Tap and hold the () for 3-5 seconds to reset the air purifier after replacing the filter.
- The () will turn OFF after successfully reset.

REPLACING THE FILTER

The () will light up to remind you to replace the filter.

DO NOT wash or reuse the filter. Only use Arovec AV-P500-RF replacement filter when changing the filter is required. This will help your air purifier to work effectively and last longer.

Replacement filter is available at www.rovec.com.au

When to Replace the Filter:

- It's best to change the filter every 4-5 months (3000 hours used). You may need to change the filter more often or less often, depending on how much you use your air purifier and on how much pollution is in the air.
- You don't need to wait for the () to turn ON for changing the filter. You may need to change the filter if you notice any of the following:
 - Increased noise from the air purifier when it is switched ON.
 - No effective difference in air quality.
 - Decreased airflow.
 - Unusual odours.
 - Clogged filter.

Steps for Replacing the Filter:

Follow these steps to replace the filter:

1. Turn OFF and unplug the air purifier. Place the air purifier on a stable surface in an upright position. Turn the base lock button to the left to unlock the base cover. [Figure 3.1]
2. Hold the air purifier and lift it up carefully. Remove the used filter from the air purifier. [Figure 3.2]

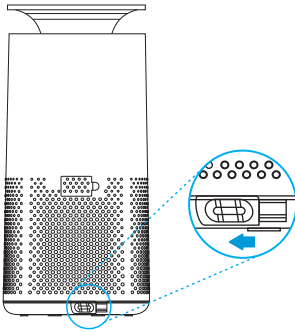

Figure 3.1

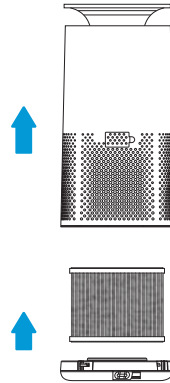

Figure 3.2

3. Clean any remaining dust or hair inside the air purifier with a vacuum cleaner. DO NOT use water or any liquids to clean the air purifier.
4. Remove the new filter from its packaging. [Figure 3.3]

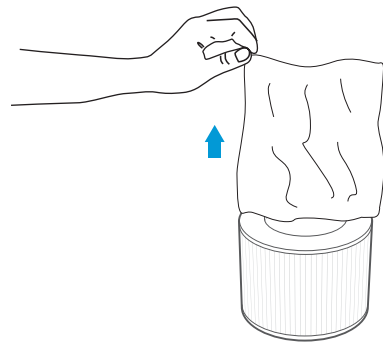

Figure 3.3

5. Put the new filter and set the air purifier on the base. [Figure 3.4]

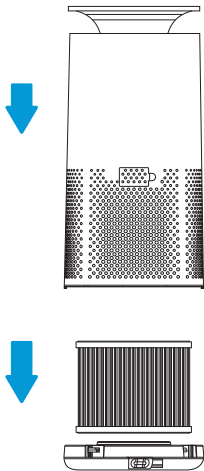

Figure 3.4

6. Turn the base lock button to the right to lock the base cover. [Figure 3.5]

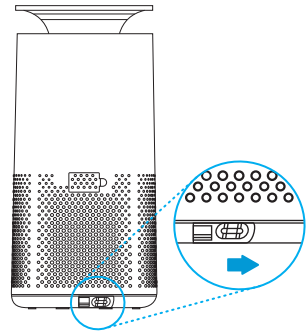



Figure 3.5

Resetting the Air Purifier After Filter Replacement:

- Turn ON the air purifier.
- Press and hold () for 3-5 seconds.
- The () light should turn OFF, which indicates that the air purifier has been reset.
- You can use the air purifier with the new filter.

CLEANING & CARE

- Turn OFF and unplug the air purifier before you clean it.
- Wipe down the outside of air purifier regularly with a soft and clean cloth.
- **DO NOT** use any harsh cleaning agents e.g., bleach or alcohol to clean any part of the air purifier.

Cleaning the filter

- To increase the efficiency and life of the filter, clean it at least once a month using a soft brush or vacuum cleaner to remove large particles, hair and dust. Do not clean the filter with water or any other liquids. [Figure 4.1]

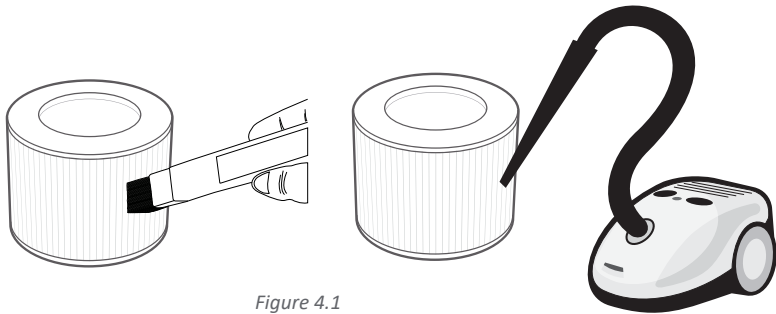

Figure 4.1

STORAGE

- If not using the air purifier for an extended period of time, it is a good idea to wrap the air purifier in plastic packaging and store in a dry place to avoid moisture damage.
- It is not recommended to store the used filter for long period of time.
- Store the air purifier in an upright position. Do not store anything on the top of air purifier.







DISPOSAL



To prevent possible harm to the environment or human health from uncontrolled waste disposal, separate the unneeded air purifier and its related accessories from other types of wastes. Ask your local council where to dispose of your air purifier and its related accessories. You should not throw your air purifier and its related accessories away with the daily normal household waste.

TROUBLESHOOTING

Here are some tips to try if your air purifier isn't working properly.

Problem	Possible Solution
Air purifier won't turn ON or buttons not working	Plug into a powered electrical outlet.
	Try plugging the air purifier into a different outlet.
	Air purifier or the cord might be damaged.
	Due to safety reason, the machine will not turn on unless the base cover is properly locked. Make sure the base cover is securely locked. The lock button at the base should be in the right side (Refer to pages 7-8 for detailed instructions).
Air purifier makes an unusual noise	Make sure the filter pack inside the machine is properly set prior locking the base cover.
	Ensure that the filter is removed from its packaging.
Significantly reduced airflow	Ensure that the filter is placed correctly as described in this user manual.
	Replace the filter.
	Check the air purifier is on a hard, flat and dry surface.
	Air purifier might be damaged or have a foreign object stuck inside.
The () indicator light is still on after changing the filter	If these solutions don't work, DO NOT use the air purifier and DO NOT try to fix the problem.
	Ensure that the filter is removed from its packaging.
	Press () to increase the fan speed.
The () indicator light hasn't turned on in 6 months	Replace the filter.
	Check there is at least 40 cm of free space around the air purifier on each side.
There is a strange smell when the air purifier is ON	Tap and hold the () for 3-5 seconds. The () indicator light should turn OFF to indicate that the air purifier has been reset.
	The () indicator light might not turn ON if you haven't used your air purifier often in the past 6 months.
	You may need to change the filter more often or less often, depending on how much you use your air purifier and on how much pollution is in the air.
The air purification quality is low	Check if the filter need to be replaced.
	Ensure that the area is not humid or there aren't any essential oils or perfumes in the area.
The air purifier is effective in areas up to 50 m ² .	Air Purifier might be damaged.
	Press () to increase the fan speed.
	Remove any debris blocking the airflow (inlet and outlet) of the air purifier.
	Ensure that the doors and windows are closed.
	Check if the filter need to be replaced.

If your problem isn't listed in the above table, please contact customer support at support@arovec.com.au for assistance.

WARRANTY AND DISCLAIMER FOR PRODUCTS

Arovec air purifiers are designed and manufactured to the highest quality standards. Your air purifier is covered for parts and labour (excluding filters) for 2 years, which includes 1 year standard warranty and 1 - additional year upon registration (free of charge within 14 days) from the date of purchasing.

Product name	Smart Plus True HEPA Air Purifier
Model	AV-P500
Standard warranty period	1 Year
Additional warranty	Extend your warranty for one additional year; Simply register on to arovec.com.au/warranty within the first 14 days of your purchase.
Record your order details here. This will help if you have any warranty questions in the future.	
Date of original purchase	
Order number	

This warranty and disclaimer applies to all products purchased via the website www.arovec.com.au (hereinafter "Products") or a third party seller authorised by Arovec.

Note: When the product is purchased from an authorised third party seller, for warranty claim, return and replacement of a defective product, the enquiry should be lodged via the related third party seller.

(1) Warranty Against Defects

1.1 For Brand-new Products:

We provide a 12-month standard warranty against defects with the Products, from the date of purchase.

We provide an optional additional free 12-month extended warranty against defects with the Products (resulting in a 24-month warranty against defects with the Products, from the date of purchase).

In order to claim the additional 12-month extended warranty, you must register your Product (free of charge) online at www.arovec.com.au, within 14 days of the date of purchase. While registration, make sure that the related data entry including the date of purchasing are accurate.

In the event of a defect with the Product, you may be entitled to have the Product replaced. In order to be entitled to a replacement Product, you must:

- immediately stop using the Product; and
- notify us of the defect during the warranty period.

In order to claim a replacement Product, you must contact us using the details at the CUSTOMER SUPPORT section, to notify us of the defect, providing your proof of purchase and warranty registration confirmation as well as your contact details.

You may either:

- return the product for our further investigation; or
- send us a video of the defective Product, which demonstrates to our reasonable satisfaction that the Product is defective and undertake to safely dispose the defective Product. For safety reasons you must not continue to use the defective Product.

Upon receipt of the defective Product, or a video of the defective Product, we will inspect it. If the defect is the result of a manufacturer fault, we will determine if the fault requires a replacement or repair and either send you a replacement Product or effect a repair.

This warranty against defects is in addition to any other rights and remedies to which you may be entitled under Australian law.

To Clarify:

What is covered by the warranty:

- The repair or replacement of your Arovec product (at Arovec's discretion) if the product is found to be defective due to faulty manufacture. Arovec reserves the right to determine if the fault requires a replacement or repair.
- Packaging and instructions of a faulty product may also be replaced if damaged.
- This warranty is valid for using your personal use of your device within Australia only.

What is not covered by the warranty:

- Using the products for commercial purposes, or anything other than normal domestic personal use.
- Use of the product outside Australia.
- Accidental damage or faults caused by negligence, misuse, vandalism or neglect.
- Damage or faults caused by not following the instructions in the user manual.
- Unsupervised use by children under the age of 18.
- Repairs or alterations carried out by parties other than Arovec or an authorised agent.
- Any other conditions not listed above, are not covered by Arovec warranty.

1.2 For Renew Products:

A renew Product, which is purchased from a seller that is authorised by Arovec, is only covered under six months warranty and is not eligible for the free warranty extension.

1.3 For Replacements:

Replacement of a brand-new Product is only covered by the one-year standard warranty from the date of replacement arrangement and is not eligible for the one-additional year free warranty extension.

Replacement of a renew Product that is purchased from a seller and is authorised by Arovec is only covered by six months warranty from the date of replacement arrangement and is not eligible for the free warranty extension.

(2) Australian Consumer Law

Our goods come with guarantees that cannot be excluded under the Australian Consumer Law. You are entitled to a replacement or refund for a major failure and compensation for any other reasonably foreseeable loss or damage. You are also entitled to have the goods repaired or replaced if the goods fail to be of acceptable quality and the failure does not amount to a major failure.

(3) Disclaimer

You are solely responsible for evaluating the Product and determining whether it is fit for your purpose.

You acknowledge and agree that Product is not safe for use by children.

You acknowledge and agree that working with the Product is dangerous and carries the risk of electric shock, burns, lacerations, other injuries and death.

You acknowledge that you use the Product at your own risk and that you are responsible at all times for evaluating whether or not it is safe to use the Product.

(4) Limitation of Liability

In addition to the requirements set out in clause 1 of this warranty and disclaimer document, the warranty provided under that clause will not apply:

- if a defect with the Product results in any way from some act or omission by you in relation to the appropriate care, maintenance and/or use of the Product; or
- if a defect with the Product results from ordinary wear and tear; or
- if you fail to follow our or the manufacturer's instructions for care, maintenance and/or use of the Product; or
- if you are unable to provide proof of purchase.

Except as otherwise provided by law, we accept no liability for any loss, damage or injury which may arise in any way from the use of the Product by you or by any other person.

Except as otherwise provided in this warranty and disclaimer, to the maximum extent permitted by law, we exclude all conditions and warranties implied by custom, law or statute, and we expressly disclaim all warranties of any kind including but not limited to implied warranties that the Product is fit for a particular purpose.

You hereby agree that we are not liable for any direct, indirect, consequential or incidental loss or damage which may result from your use of the Product.

Except as otherwise provided by law or as otherwise set out in this warranty and disclaimer, our liability to you shall be limited to the cost of replacement of the Product, together with your reasonable costs of postage and/or delivery in connection with your returning of the Product.

(5) Indemnity

You agree to defend, indemnify and hold us and our officers, directors, employees, contractors, members, agents and licensees harmless from and against any and all claims, charges, actions, liabilities, investigations, demands and similar including but not limited to any costs, losses, damages whether direct, indirect, consequential or special and all legal fees resulting from your use of the Product, including but not limited to any third party claims.

CUSTOMER SUPPORT - AUSTRALIA

Feel free to contact our helpful customer support team with any questions or inquiries regarding your product.

Your satisfaction is our priority.

Ausbrilliant Brands

PO Box2, Ermington NSW 1700, Australia

www.avec.com.au

support@avec.com.au

Please provide your order number when you contact customer support.

Alternatively, you may contact us using the contact us form on the website.



www.arovec.com.au

Questions or Concerns?

support@arovec.com.au

V4.0922