

## **Smart Compact Air Purifier**

**Model: AV-P300, AV-P300B**

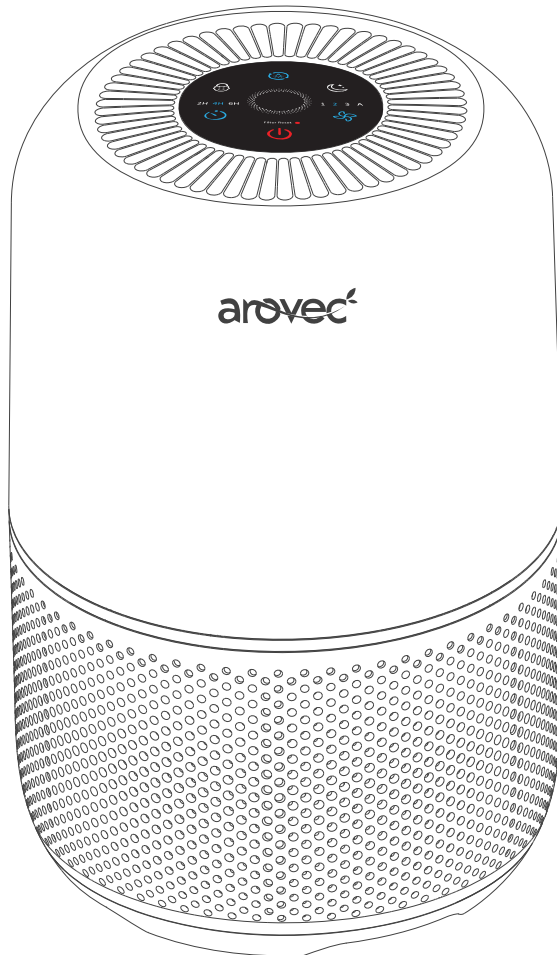

This user manual provides safety and operating instructions.  
Please read this user manual thoroughly before using the product.



## TABLE OF CONTENTS

Important Safety Instructions	4
Introduction	5
Getting to Know Your Air Purifier	6
Before Using For The First Time	7
General Tips	8
Operation	9
Replacing The Filter	12
Cleaning & Care, Storage, Disposal	15
Troubleshooting	16
Warranty Information	17
Customer Support - Australia	21

## PACKAGE CONTENT

- 1 x Smart Compact H13 True HEPA Air Purifier
- 1 x Filter Package (Pre-fitted in Air Purifier)
- 1 x User Manual
- 1 x Warranty Card

## PRODUCT SPECIFICATION

<b>Power Supply</b>	220-240 V~, 50 Hz
<b>Rated Power</b>	32 W
<b>Effective Range</b>	Areas up to 30 m <sup>2</sup>
<b>Operating Conditions</b>	Temperature: -10 °C to 40 °C Humidity: < 85% RH
<b>Noise Level</b>	28 - 49 dB
<b>Standby Power</b>	< 0.8 W
<b>Weight</b>	2.9 kg
<b>Dimensions</b>	ø 21.5 × H33 cm
<b>CADR (smoke)</b>	160 m <sup>3</sup> /h
<b>Filter Pack</b>	3-Layered Filtration System Plus Extra Protection Net: <ol style="list-style-type: none"><li>1. Preliminary Filter</li><li>2. High-Grade H13 True HEPA Filter</li><li>3. Activated Carbon Filter</li></ol> + Polypropylene Net

## THANK YOU FOR CHOOSING TO BUY AN AROVEC AIR PURIFIER

We are here to help you with any questions.  
Customer Support - AUSTRALIA

- 🌐 [www.rovec.com.au](http://www.rovec.com.au)
- ✉ [support@rovec.com.au](mailto:support@rovec.com.au)
- 📱 @roveclifestyle

## IMPORTANT SAFETY INSTRUCTIONS

Please read all instructions before use to prevent the risk of injury, fire, electric shock or damage.

- **DO NOT** use the air purifier before removing the plastic packaging from the filter. It is a fire hazard to use your air purifier with the filter still inside its packaging.
- **DO NOT** use the air purifier if it has been dropped, damaged, left outside, dropped in water, or not working properly.
- **DO NOT** use the air purifier if the cord or plug looks damaged.
- **DO NOT** use the air purifier near gas appliances, fireplaces, stoves, candles, or heating devices.
- **DO NOT** use the air purifier in an area with insect repellents, burning incense, toxic fumes, flammable dust or oxygen tanks. Always leave at least 1.5 m of clear space from any oxygen being administered.
- **DO NOT** touch any part of the air purifier or its plug with wet hands.
- **DO NOT** run the power cord under furniture, other appliances, carpet, or cover with rugs, runners or floor coverings.
- **ALWAYS** tuck away the power cord to prevent tripping accidents.
- **DO NOT** put the air purifier on an unstable surface e.g. bed or couch.
- **DO NOT** use the air purifier and power plug on wet or damp surfaces.
- **DO NOT** put the air purifier in water or liquids.
- **DO NOT** keep air purifier under an air conditioner to help prevent moisture getting into the unit.
- **DO NOT** use the air purifier outdoors.
- **DO NOT** use the air purifier in a room that can have a big change in temperature. This will help minimise the risk of condensation.
- **DO NOT** put fingers or any objects into the air inlet/outlet of the air purifier.
- **DO NOT** use a defective air purifier or attempt to repair/adjust any electrical or mechanical functions, this may cause danger and void the warranty.
- **DO NOT** let children or people with reduced physical or mental capabilities to use or clean the air purifier.
- **DO NOT** let children play with this appliance or its packaging including plastic bag. Children must be supervised around the air purifier to help keep them safe.
- **DO NOT** sit on the air purifier or put any objects on top of the unit.
- **DO NOT** block/obscure the air inlet or outlet. Keep free of anything that could reduce airflow.
- **DO NOT** spray air fresheners, perfumes or oils on or near the filter.
- **DO NOT** fit the air purifier with a different power supply unit.
- **DO NOT** clean the air purifier or change the filter with the power cord plugged in.
- **DO NOT** use the air purifier for commercial purposes. This appliance is for household use only.
- It is recommended to **NOT** use the unit with an extension cord to avoid electrical shock or spark.
- **TURN OFF** the air purifier when it is not being used. Hold the plug and remove it from the electrical source. Do not unplug by pulling the cable.
- **WARNING:** This air purifier does not remove carbon monoxide or radon from the air. It must not be used to prevent or clean up accidents with combustion processes and hazardous chemicals.

## KEEP THESE INSTRUCTIONS IN A SAFE PLACE

# INTRODUCTION

The AV-P300 True HEPA air purifier removes contaminants from the air to improve indoor air quality. Be aware of the real-time air quality changes in your room with help of air quality sensor in the AV-P300.

Arovec AV-P300 air purifier uses a system of internal fan to pull the air in your room through a high-efficiency filtration system that removes harmful airborne particles like dust, pollen and bacteria. Keep your environment healthy with AV-P300.

## PRODUCT FEATURES

**Smart Sensor & Auto-Mode:** The smart air quality sensor in this air purifier intelligently detects PM2.5 levels and the purification speed automatically adjust accordingly in Auto-Mode to effectively deal with the pollution level.

**Peaceful Sleep:** Have an undisturbed deep sleep while the air purifier is quietly operating in Sleep-Mode. You can also turn off the display and light for a dark sleeping environment.

**High-Efficiency Filtration System:** This replacement filter contains multiple stage filtration system plus extra protection net, which filters out 99.97% airborne harmful pollutants including particulate matters PM2.5, VOCs, dust, pollen, odour, allergens, cigarette & other smokes, cooking smell, pet dander & smell, mould, bacteria and other airborne contaminants as small as 0.3µm with 100% ozone free safe operation.

- 1. Preliminary Filter:** Captures large particles such as dust, pet dander and hair.
  - 2. True HEPA Filter:** High grade H13 True HEPA Filter traps fine particles such as PM2.5, dust mites, allergens, airborne bacteria, pollen, mould and other airborne contaminants as small as 0.3µm.
  - 3. High-Efficiency Activated Carbon Filter:** Adsorbs various odours and smokes such as cigarette smoke, fumes, cooking smell, pet odours, hazardous gases and VOCs.
- + Polypropylene Net:** Extra protection of Activated Carbon Filter for its enhanced efficiency.

# GETTING TO KNOW YOUR AIR PURIFIER

1. Light / Display-off Button
2. Child-Lock Button
3. Timer Indicators
4. Timer Button
5. Power Button
6. Sleep Mode Button
7. Fan Speed Indicators
8. Fan Speed Button
9. Filter Reset Indicator
10. Air Quality Light / Night Light
11. Air Outlet
12. Air Inlet
13. Power Cord
14. Base Cover
15. Filter Pack
  - 15.a Preliminary Filter
  - 15.b True HEPA Filter
  - 15.c Activated Carbon Filter
  - 15.d Polypropylene Net
16. Dust Sensor

**Top View**

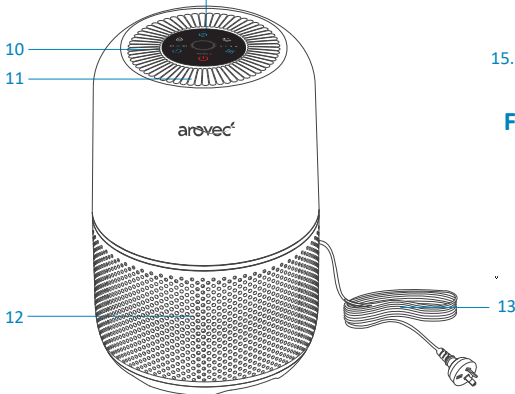
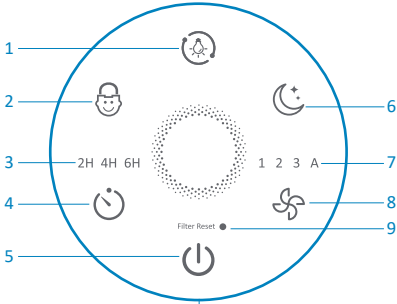

**Front View**

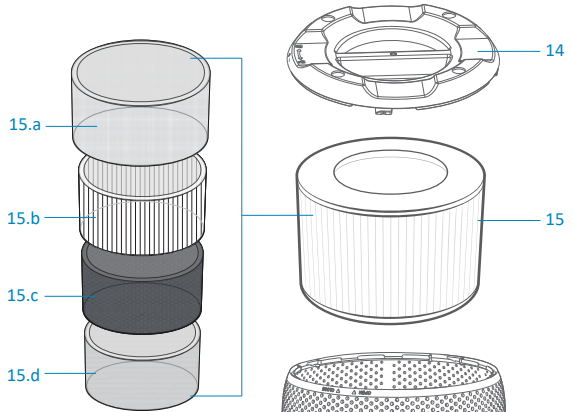

**Filter Internal Details**

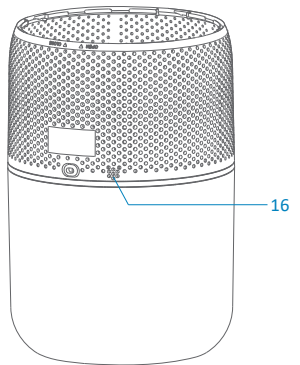

**Upside Down View**

## BEFORE USING FOR THE FIRST TIME

The air purifier comes with the filter fitted inside, but they are packaged in plastic. You must remove the filter from its packaging before turning the air purifier on.

1. Turn the air purifier upside down on a soft cloth. [Figure 1.1]
2. Turn the base cover anticlockwise to unlock the cover. [Figure 1.1]
3. Remove the base cover. [Figure 1.2]
4. Remove the filter from the air purifier. [Figure 1.2]

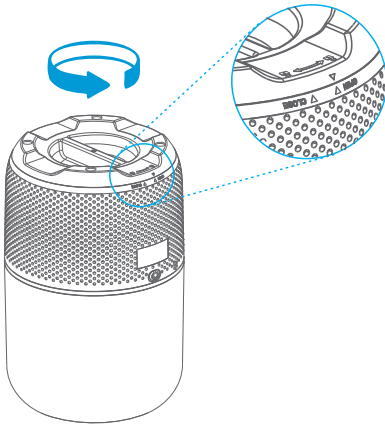

Figure 1.1

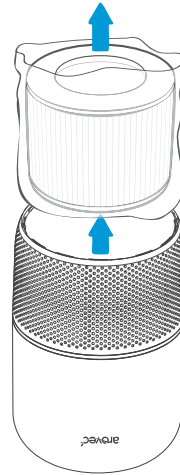

Figure 1.2

5. Remove the filter from its packaging. [Figure 1.3]

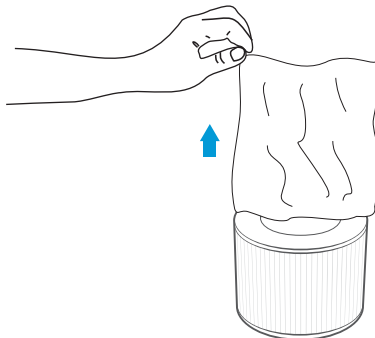

Figure 1.3

6. Put the filter back into the air purifier. [Figure 1.4]

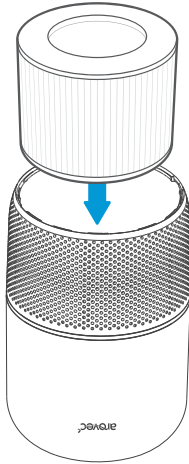

Figure 1.4

7. Put the base cover back on and turn it clockwise to the lock position. [Figure 1.5]

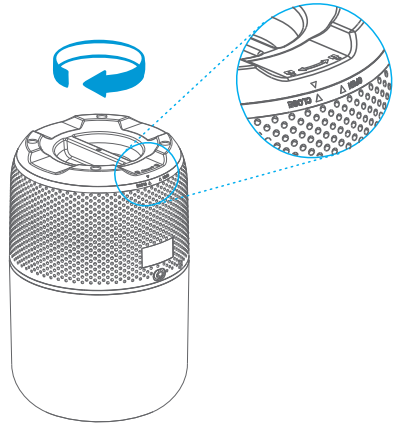

Figure 1.5

## GENERAL TIPS

- The air purifier should be on a flat, level surface, with the control panel facing up before switching it on. [Figure 2.1]
- Leave at least 40 cm of clear space around each side of the purifier when it is on. [Figure 2.1]

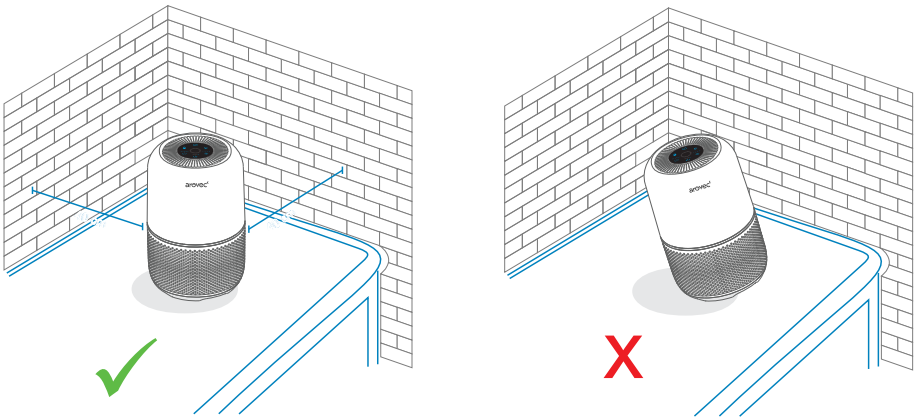

Figure 2.1

- Shut nearby windows when the air purifier is turned ON to help clean the air.
- For best results, use the air purifier for 15-20 minutes at the maximum fan speed, then adjust the fan speed as required.



# OPERATION



Plug in the air purifier into an electrical outlet.



### POWER Button:

- Tap (  ) once to turn the air purifier ON or OFF.

### FILTER RESET:



- The ( Filter Reset  ) indicator will light up to remind you to replace the filter.
- Tap and hold the (  ) for 3-5 seconds to reset the air purifier after replacing the filter.







### FAN SPEED Button:

- There are 3 fan-speed options; 1 (low), 2 (medium), 3 (high) and an AUTO mode (A).
- Each tap will toggle to the next fan speed level.

### AUTO MODE:

- The (  ) denotes for AUTO mode. Choose (  ) from the fan setting to activate the AUTO mode.
- In AUTO mode, the air quality light changes its colour based on detected air quality and fan speed adjusts accordingly. [Table 1]

[Table 1]

Auto Mode Setting	
Colour	Air Quality
Blue 	Very Good
Green 	Good
Orange 	Moderate
Red 	Poor

Note: It will take 1 minute for the dust sensor to detect the air quality after the Air Purifier turned on.

### Memory Function:

- The air purifier keeps the control settings when it's turned off. When the air purifier is plugged-in it will remember its previous fan speed setting.
- The fan speed level will return to the previous setting when the air purifier is turned back ON.
- Please note that the air purifier must remain plugged-in for this memory function to work.



### SLEEP MODE Button:





- In sleep mode, the air purifier runs quietly on lowest fan speed and all indicators turn off including air quality light except sleep indicator.
- Tap ( 🌙 ) to enter sleep mode. The sleep indicator will be blinking for 3-5s, then the air purifier enters to sleep mode.
- When the air purifier is running in Sleep mode, the timer, night light and child lock can be controlled independently by their related buttons.
- To end the sleep mode tap ( 🌙 ) or ( 🌀 ).



### AIR QUALITY LIGHT / DISPLAY-OFF Button:

- The LED light is the air quality indicator in four different colours. [Table 2]

[Table 2]



Air Quality Indicator Table			
Colour		Air Quality	*AQI Measured in PM2.5
Blue		Very Good	< 35
Green		Good	35 – 66
Orange		Moderate	67 – 100
Red		Poor	> 100

Note: It will take 1 minute for the dust sensor to detect the air quality after the Air Purifier turned on.  
\*Air Quality Index

- Tap once the ( 🌟 ) to turn ON or OFF the air quality light.
- When the air purifier is running, the LED light colour will change according to the detected air quality.
- Hold ( 🌟 ) for 3-5s to turn OFF all the indicators and lights.
- The LED light can be used as a night light with orange colour even if the air purifier is not running.
  - Tap once ( 🌟 ) to turn the night light to full brightness.
  - 2<sup>nd</sup> tap ( 🌟 ) to change the night light to half brightness.
  - 3<sup>rd</sup> tap ( 🌟 ) to turn off the night light.



### CHILD-LOCK Button:







- In child-lock mode the control panel will deactivate.
- Press and hold (  ) for 3-5 seconds to enter child-lock mode.
- Press and hold again (  ) for 3-5 seconds to exit the child-lock mode and activate the control panel.



### TIMER Button:

- You can set a timer for 2, 4, 6, 8, or 12 hours. [Table 3]
- Tap (  ) repeatedly to select a time.

[Table 3]

Timer Setting Table						
Tap (  ) repeatedly to select a time	1 <sup>st</sup> Tap (  )	2 <sup>nd</sup> Tap (  )	3 <sup>rd</sup> Tap (  )	4 <sup>th</sup> Tap (  )	5 <sup>th</sup> Tap (  )	6 <sup>th</sup> Tap (  )
Indicator light up	2H	4H	6H	2H + 6H	2H + 4H + 6H	All timer indicators turn OFF
Selected time	2 hours	4 hours	6 hours	8 hours	12 hours	Timer cancelled

- The air purifier will automatically turn OFF once the timer is finished.
- If no timer is set, the air purifier will continuously operate until it is manually turned off.
- To cancel the timer, tap (  ) until all timer indicators turn OFF.

## REPLACING THE FILTER

The ( Filter Reset ● ) will light up to remind you to replace the filter.

DO NOT wash or reuse the filter. Only use Arovec AV-P300-RF replacement filter when changing the filter is required. This will help your air purifier to work effectively and last longer.

Replacement filter is available at [www.arovec.com.au](http://www.arovec.com.au)

### When to Replace the Filter:

- It's best to change the filter every 4-5 months (3000 hours used). You may need to change the filter more often or less often, depending on how much you use your air purifier and on how much pollution is in the air.
- You don't need to wait for the ( Filter Reset ● ) to turn ON for changing the filter. You may need to change the filter if you notice any of the following:
  - Increased noise from the air purifier when it is switched ON.
  - No effective difference in air quality.
  - Decreased airflow.
  - Unusual odours.
  - Clogged filter.

## Steps for Replacing the Filter:

Follow these steps to replace the filter:

1. Turn OFF and unplug the air purifier.
2. Turn the air purifier upside down on a soft cloth. [Figure 3.1]
3. Turn the base cover anticlockwise to unlock the cover. [Figure 3.1]
4. Remove the base cover. [Figure 3.2]
5. Remove the used filter from the air purifier. [Figure 3.2]

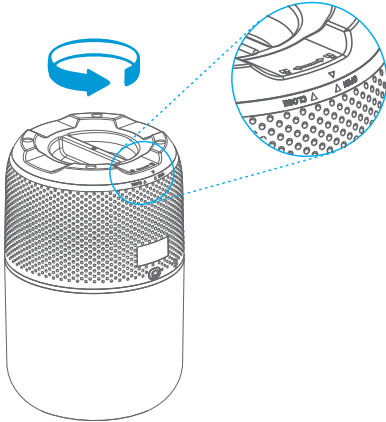

Figure 3.1

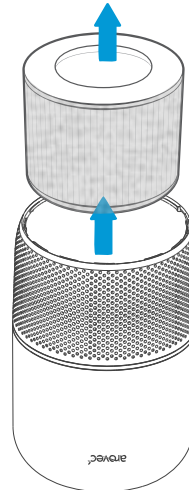

Figure 3.2

6. Clean any remaining dust or hair inside the air purifier with a vacuum cleaner. DO NOT use water or any liquids to clean the air purifier. [Figure 3.3]
7. Remove the new filter from its packaging. [Figure 3.4]

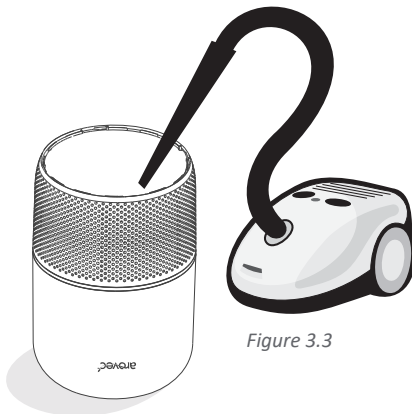

Figure 3.3

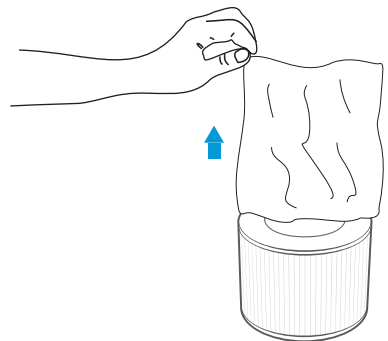

Figure 3.4

8. Place the new filter into the air purifier. [Figure 3.5]

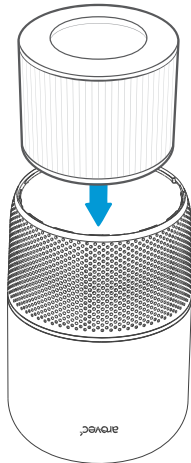

Figure 3.5

9. Put the base cover back on and turn it clockwise to lock the cover. [Figure 3.6]

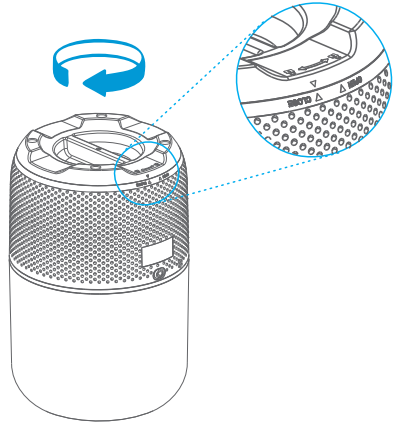

Figure 3.6

### Resetting the Air Purifier After Filter Replacement:

You need to reset the air purifier in two conditions.

1. If the filter was replaced after the ( Filter Reset ● ) light up:
  - Turn ON the air purifier.
  - Press and hold ( ⏻ ) for 3-5 seconds.
  - The ( Filter Reset ● ) light should turn OFF, which indicates that the air purifier has been reset.
  - You can use the air purifier with the new filter.
2. If the filter was replaced before the ( Filter Reset ● ) light up:
  - Plug in the air purifier after filter replacement, but do not turn ON the air purifier.
  - Press and hold ( ⏻ ) for 3-5 seconds to light up the ( Filter Reset ● ).
  - Press and hold again ( ⏻ ) for 3-5 seconds to turn OFF the ( Filter Reset ● ), the reset is now complete.
  - You can turn on and use the air purifier with the new filter.

## CLEANING & CARE



- Turn OFF and unplug the air purifier before you clean it.
- Wipe down the outside of air purifier regularly with a soft and clean cloth.
- **DO NOT** use any harsh cleaning agents e.g., bleach or alcohol to clean any part of the air purifier.

### Cleaning the filter

- To increase the efficiency and life of the filter, clean it at least once a month using a soft brush or vacuum cleaner to remove large particles, hair and dust. Do not clean the filter with water or any other liquids. [Figure 4.1]

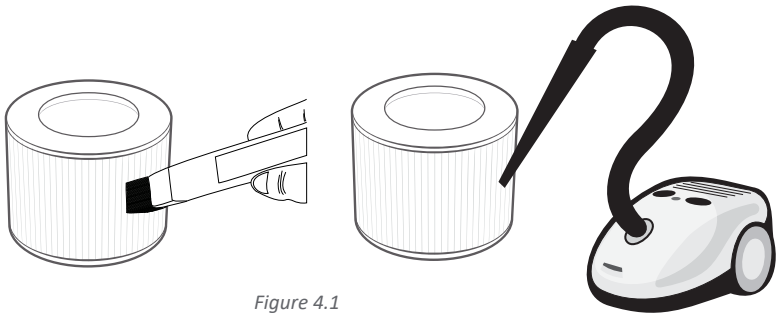

Figure 4.1

## STORAGE









- If not using the air purifier for an extended period of time, it is a good idea to wrap both the air purifier and the filters in plastic packaging and store them in a dry place to avoid moisture damage.
- Ensure the air purifier is powered OFF by removing the power plug from the power outlet.
- Store the air purifier in an upright position. Do not store anything on the top of air purifier.

## DISPOSAL



To prevent possible harm to the environment or human health from uncontrolled waste disposal, separate the unneeded air purifier and its related accessories from other types of waste. Ask your local council where to dispose of your air purifier and its related accessories. You should not throw your air purifier and its related accessories away with the daily normal household waste.

# TROUBLESHOOTING

Problem	Possible Solution
Air purifier won't turn ON or buttons not working	Plug into a powered electrical outlet.
	Try plugging the air purifier into a different outlet.
	Air purifier or the cord might be damaged.
	If these solutions don't work, DO NOT use the air purifier.
Air purifier makes an unusual noise	Ensure that the filter is removed from its packaging.
	Ensure that the filter is placed correctly as described in this user manual.
	Replace the filter.
	Check the air purifier is on a hard, flat and dry surface.
	Air purifier might be damaged or have a foreign object stuck inside.
	If these solutions don't work, DO NOT use the air purifier and DO NOT try to fix the problem.
Significantly reduced airflow	Ensure that the filter is removed from its packaging.
	Press (  ) to increase the fan speed.
	Replace the filter.
	Check there is at least 40 cm of free space around the air purifier on each side.
The ( Filter Reset  ) indicator light is still on after changing the filter	Tap and hold the ( Filter Reset  ) for 3-5 seconds. The ( Filter Reset  ) indicator light should turn OFF to indicate that the air purifier has been reset.
The ( Filter Reset  ) indicator light hasn't turned on in 6 months	The ( Filter Reset  ) indicator light might not turn ON if you haven't used your air purifier often in the past 6 months. You may need to change the filter more often or less often, depending on how much you use your air purifier and on how much pollution is in the air.
There is a strange smell when the air purifier is ON	Check if the filter needs to be replaced.
	Ensure that the area is not humid or there aren't any essential oils or perfumes in the area.
	Air Purifier might be damaged.
The air purification quality is low	Press (  ) to increase the fan speed.
	The air purifier is effective in areas up to 30 m <sup>2</sup> .
	Remove any debris blocking the airflow (inlet and outlet) of the air purifier.
	Ensure that the doors and windows are closed.
	Check if the filter needs to be replaced.

If your problem isn't listed in the above table, please contact customer support at [support@arovec.com.au](mailto:support@arovec.com.au) for assistance.



## WARRANTY AND DISCLAIMER FOR PRODUCTS

Arovec air purifiers are designed and manufactured to the highest quality standards. Your air purifier is covered for parts and labour (excluding filters) for 2 years, which includes 1 year standard warranty and 1 - additional year upon registration (free of charge within 14 days) from the date of purchasing.

Product name	Smart Compact Air Purifier
Model	AV-P300 / AV-P300B
Standard warranty period	1 Year
Additional warranty	Extend your warranty for one additional year; Simply register on <a href="http://arovec.com.au/warranty">arovec.com.au/warranty</a> within the first 14 days of your purchase.
Record your order details here. This will help if you have any warranty questions in the future.	
Date of original purchase	
Order number	

This warranty and disclaimer applies to all products purchased via the website [www.arovec.com.au](http://www.arovec.com.au) (hereinafter "Products") or a third-party seller authorised by Arovec.

**Note:** When the product is purchased from an authorised third-party seller, for warranty claim, return and replacement of a defective product, the inquiry should be lodged on the related third-party seller.

### (1) Warranty Against Defects

#### 1.1 For Brand-new Products:

We provide a 12-month standard warranty against defects with the Products, from the date of purchase.

We provide an optional additional free 12-month extended warranty against defects with the Products (resulting in a 24-month warranty against defects with the Products, from the date of purchase).

In order to claim the additional 12-month extended warranty, you must register your Product (free of charge) online at [www.arovec.com.au](http://www.arovec.com.au), within 14 days of the date of purchase. While registering, make sure that the related data entry including the date of purchase is accurate.

In the event of a defect with the Product, you may be entitled to have the Product replaced. In order to be entitled to a replacement Product, you must:

- immediately stop using the Product; and
- notify us of the defect during the warranty period.

In order to claim a replacement Product, you must contact us using the details at the CUSTOMER SUPPORT section, to notify us of the defect, providing your proof of purchase and warranty registration confirmation as well as your contact details.

You may either:

- return the product for our further investigation; or
- send us a video of the defective Product, which demonstrates to our reasonable satisfaction that the Product is defective and undertake to safely dispose of defective Product. For safety reasons you must not continue to use the defective Product.

Upon receipt of the defective Product, or a video of the defective Product, we will inspect it. If the defect is the result of a manufacturer fault, we will determine if the fault requires a replacement or repair and either send you a replacement Product or effect a repair.

This warranty against defects is in addition to any other rights and remedies to which you may be entitled under Australian law.

To Clarify:

#### **What is covered by the warranty:**

- The repair or replacement of your Arovec product (at Arovec's discretion) if the product is found to be defective due to faulty manufacture. Arovec reserves the right to determine if the fault requires a replacement or repair.
- Packaging and instructions of a faulty product may also be replaced if damaged.
- This warranty is valid for using your personal use of your device within Australia only.

#### **What is not covered by the warranty:**

- Using the products for commercial purposes, or anything other than normal domestic personal use.
- Use of the product outside Australia.
- Accidental damage or faults caused by negligence, misuse, vandalism or neglect.
- Damage or faults caused by not following the instructions in the user manual.
- Unsupervised use by children under the age of 18.
- Repairs or alterations carried out by parties other than Arovec or an authorised agent.
- Any other conditions not listed above, are not covered by Arovec warranty.

### **1.2 For Renew Products:**

A renewed Product, which is purchased from a seller that is authorised by Arovec, is only covered under six months warranty and is not eligible for the free warranty extension.

### **1.3 For Replacements:**

Replacement of a brand-new Product is only covered by the one-year standard warranty from the date of replacement arrangement and is not eligible for the one-additional year free warranty extension.

Replacement of a renew Product that is purchased from a seller and is authorised by Arovec is only covered by six months warranty from the date of replacement arrangement and is not eligible for the free warranty extension.

## **(2) Australian Consumer Law**

Our goods come with guarantees that cannot be excluded under the Australian Consumer Law. You are entitled to a replacement or refund for a major failure and compensation for any other reasonably foreseeable loss or damage. You are also entitled to have the goods repaired or replaced if the goods fail to be of acceptable quality and the failure does not amount to a major failure.

## **(3) Disclaimer**

You are solely responsible for evaluating the Product and determining whether it is fit for your purpose.

You acknowledge and agree that Product is not safe for use by children.

You acknowledge and agree that working with the Product is dangerous and carries the risk of electric shock, burns, lacerations, other injuries and death.

You acknowledge that you use the Product at your own risk and that you are responsible at all times for evaluating whether or not it is safe to use the Product.

## **(4) Limitation of Liability**

In addition to the requirements set out in clause 1 of this warranty and disclaimer document, the warranty provided under that clause will not apply:

- if a defect with the Product results in any way from some act or omission by you in relation to the appropriate care, maintenance and/or use of the Product; or
- if a defect with the Product results from ordinary wear and tear; or
- if you fail to follow our or the manufacturer's instructions for care, maintenance and/or use of the Product; or
- if you are unable to provide proof of purchase.

Except as otherwise provided by law, we accept no liability for any loss, damage or injury which may arise in any way from the use of the Product by you or by any other person.

Except as otherwise provided in this warranty and disclaimer, to the maximum extent permitted by law, we exclude all conditions and warranties implied by custom, law or statute, and we expressly disclaim all warranties of any kind including but not limited to implied warranties that the Product is fit for a particular purpose.

You hereby agree that we are not liable for any direct, indirect, consequential or incidental loss or damage that may result from your use of the Product.

Except as otherwise provided by law or as otherwise set out in this warranty and disclaimer, our liability to you shall be limited to the cost of replacement of the Product, together with your reasonable costs of postage and/or delivery in connection with your returning of the Product.

## **(5) Indemnity**

You agree to defend, indemnify and hold us and our officers, directors, employees, contractors, members, agents and licensees harmless from and against any and all claims, charges, actions, liabilities, investigations, demands and similar including but not limited to any costs, losses, damages whether direct, indirect, consequential or special and all legal fees resulting from your use of the Product, including but not limited to any third-party claims.

## CUSTOMER SUPPORT - AUSTRALIA

Feel free to contact our helpful customer support team with any questions or inquiries regarding your product.

Your satisfaction is our priority.

Ausbrilliant Brands

PO Box2, Ermington NSW 1700, Australia

[www.avec.com.au](http://www.avec.com.au)

[support@avec.com.au](mailto:support@avec.com.au)

Please provide your order number when you contact customer support.

Alternatively, you may contact us using the contact us form on the website.

**NOTES**

---

---

---

---

---

---

---

---

---

---

---





[www.arovec.com.au](http://www.arovec.com.au)

**Questions or Concerns?**  
[support@arovec.com.au](mailto:support@arovec.com.au)

V4.0223