

Air Dehumidifier

Model: AroDry-900



This user manual provides safety and operating instructions.
Please read this user manual thoroughly before using the product.
This user manual will help get your dehumidifier going in just a few quick minutes.

TABLE OF CONTENTS

Important Safety Instructions	4
Introduction	5
Getting to know your dehumidifier	6
General Tips	7
Operation	8
Draining The Collected Water	8
Cleaning & Care, Storage, Disposal	9
Troubleshooting	10
Warranty Information	11
Defective Products & Returns	13
Customer Support – Australia	13

PACKAGE CONTENTS

1 x AroDry-900 Air Dehumidifier
1 x Power Adapter
1 x User Manual
1 x Warranty Card

PRODUCT SPECIFICATIONS

Power Adapter	Input: AC 100V – 240V, 50/60Hz, 1.0A
	Output: DC 9V, 2.5A
Rated Power	23W
Effective Range	Areas up to 15m ²
Operating Conditions	>15°C, >40%RH
Noise Level	<30dB
Standby Power	0.4W
Dehumidify Capacity	Approx. 300ml/day at 30°C, 80%RH
Water Tank Capacity	900ml
Dimensions	14.5 × 14.5 × 22cm
Net Weight	0.9kg

THANK YOU FOR CHOOSING TO BUY AN AROVEC AIR DEHUMIDIFIER

We are here to help you with any questions.
Customer Support- AUSTRALIA

🌐 www.ovec.com.au
✉ support@ovec.com.au
📷 @oveclifestyle

IMPORTANT SAFETY INSTRUCTIONS

Please read all instructions before use to prevent the risk of injury, fire, electric shock or damage. Use your dehumidifier safely by following the instructions in this manual.

- **ALWAYS** turn off and unplug the dehumidifier before emptying the water tank.
- **DO NOT** move the dehumidifier when the water tank is full to prevent water spillage.
- **DO NOT** use the dehumidifier if it has been dropped, damaged, left outside, dropped in water or not working properly.
- **DO NOT** turn on the dehumidifier when the water tank is removed from the unit.
- **DO NOT** remove the water tank when the dehumidifier is turned on.
- **DO NOT** use the dehumidifier if the cord or adapter looks damaged.
- **DO NOT** use the dehumidifier near gas appliances, fire places, stoves, candles, or heating devices.
- **DO NOT** use the dehumidifier in an area with insect repellents, burning incense, toxic fumes, flammable dust or oxygen tanks. Always leave at least 1.5m of clear space from any oxygen being administered.
- **DO NOT** run the power cord under furniture, other appliances, carpet, or cover with rugs, runners or floor covering.
- **ALWAYS** tuck away the power cord to prevent tripping accidents.
- **DO NOT** put the dehumidifier on an unstable surface e.g. bed or couch.
- **DO NOT** use the power adapter on wet or damp surfaces.
- **DO NOT** touch any part of the humidifier or adapter with wet hands.
- **DO NOT** put the dehumidifier in water or liquids.
- **DO NOT** use the dehumidifier outdoor.
- **DO NOT** use for commercial purposes. This appliance is for household only.
- **DO NOT** put any object into the air inlet/outlet.
- **DO NOT** attempt to repair or adjust any electrical or mechanical functions of the dehumidifier, as this may cause danger and void the warranty.
- **DO NOT** let children or people with reduced physical or mental capabilities to use or clean the dehumidifier.
- **DO NOT** let children play with this appliance or packaging including plastic bag. Children must be supervised around the dehumidifier to help keep them safe.
- **DO NOT** sit on the dehumidifier or put any object on the top of the unit.
- **DO NOT** block/obscure the air inlet/outlet. Keep free of anything that could reduce airflow.
- **DO NOT** spray air fresheners, perfumes or oils on or near the dehumidifier.
- **DO NOT** fit the dehumidifier with a different power supply unit.
- **DO NOT** clean with the power adapter plugged in.
- It is recommended to NOT use the appliance with an extension cord to avoid electrical shock or spark.
- **TURN OFF** the dehumidifier when it is not being used. Hold the adapter and remove it from the electrical outlet.

KEEP THESE INSTRUCTIONS IN A SAFE PLACE.

INTRODUCTION

Arovec AroDry-900 dehumidifier reduces humidity levels, making your home less hospitable to allergens such as dust mites, mould and mildew. Getting rid of musty or rotting smell. Additionally, the stylish design adds beauty to your room.

PRODUCT FEATURES

Easy to Operate: Simple and easy operation with a single button.

Quiet Operation: Helps you get clean and healthy air in your room while runs quietly.

LED Light: Built-in night light with colour changing, fixed colour or entirely turn off options.

Removable Water Tank: Easily remove the water tank and drain the collected water.

Auto Shut-off Function: AroDry-900 will shut off automatically when water tank is full to prevent water overflow.

GETTING TO YOUR DEHUMIDIFIER

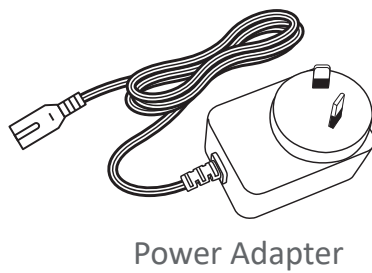
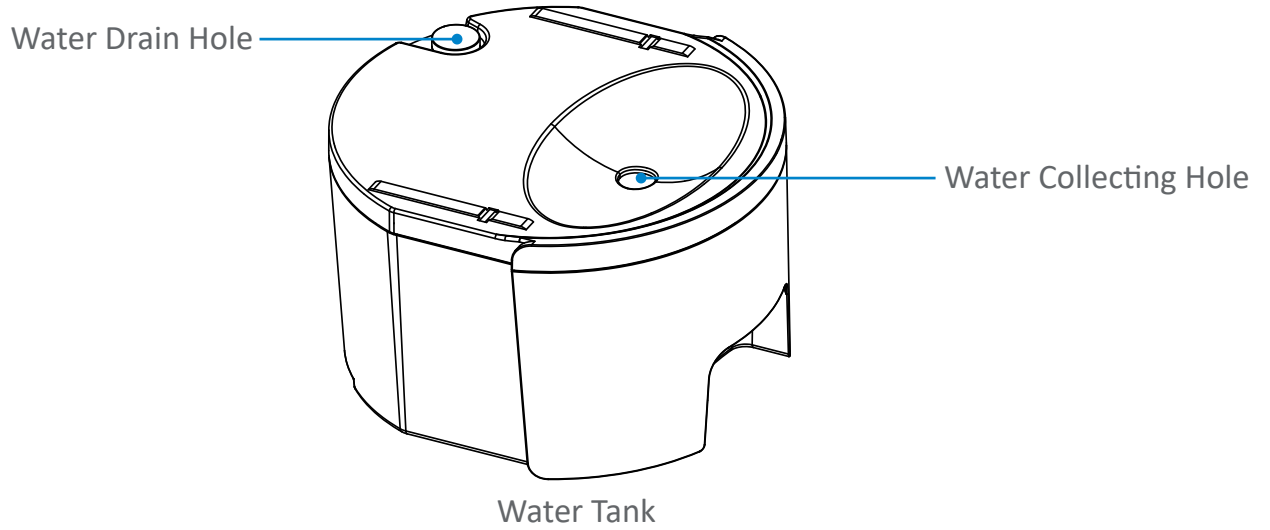
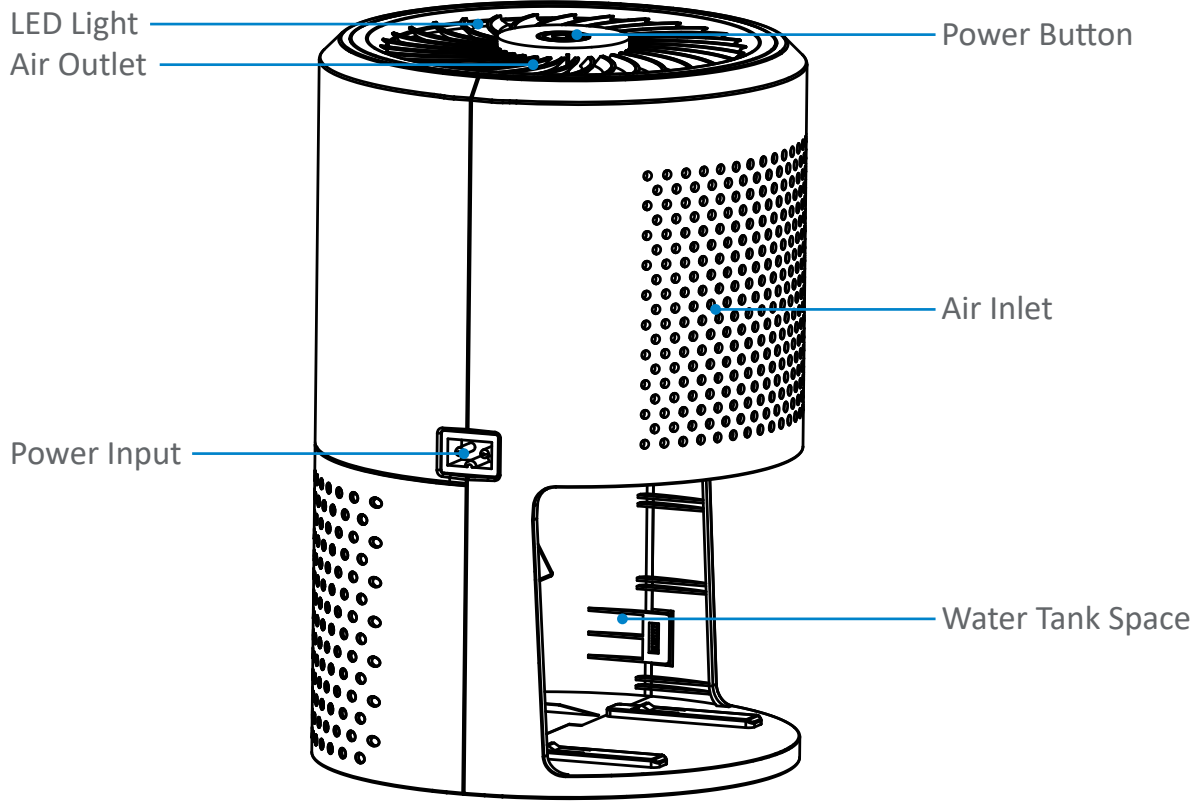

GENERAL TIPS

- The dehumidifier should be on a flat, level surface, with the control panel facing up before switching it ON. [Figure 1.1]

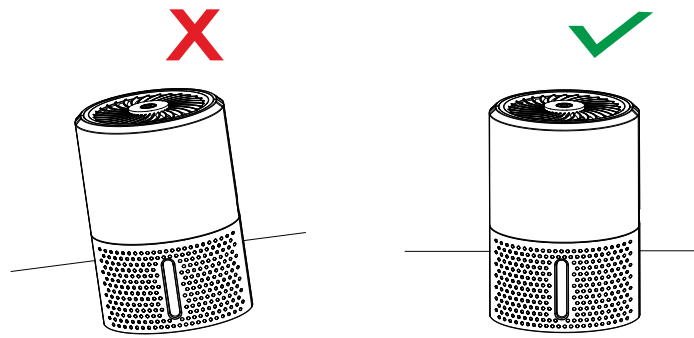

Figure 1.1

- Leave at least 40 cm of clear space around each side of the dehumidifier when it is ON. [Figure 1.2]

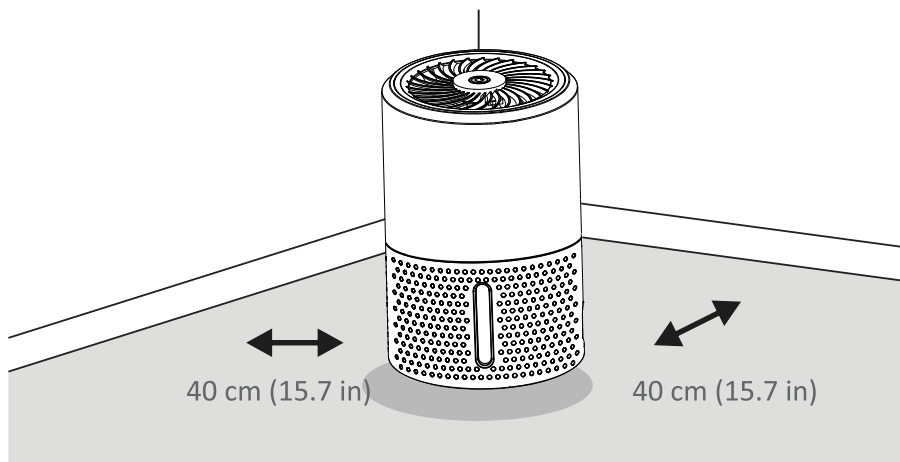

Figure 1.2

- For optimal efficiency, shut all windows and doors when the dehumidifier is operating. [Figure 1.3]

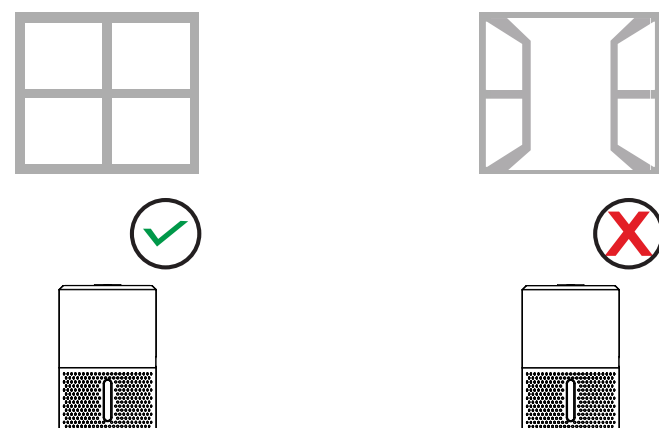

Figure 1.3

OPERATION



CONTROL BUTTON

- 1st press (⏻): Turn ON dehumidifier, Turn ON night light with changing colour.
- 2nd press (⏻): Turn ON dehumidifier, Turn ON night light with fixed colour.
- 3rd press (⏻): Turn ON dehumidifier, Turn OFF night light.
- 4th press (⏻): Turn OFF dehumidifier, Turn OFF night light.



AUTO SHUT OFF

- Dehumidifier will shut off automatically when water tank is full or removed, and the LED light will start flashing.
- Built-in automatic shut off protection prevents flooding or water overflow.

DRAINING THE COLLECTED WATER

When the water tank is full (approx. 900ml of water collected), the dehumidifier will automatically turn OFF and the LED light will start flashing.

1. Switch off the dehumidifier and remove the water tank. [Figure 2.1]



Figure 2.1

2. Pull out the rubber plug to open the drain hole. Drain the collected water from the water tank. [Figure 2.2]

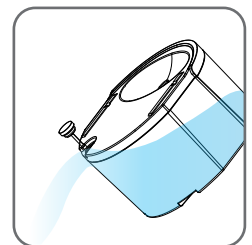

Figure 2.2

2. Replace back the rubber plug to close the drain hole. Put the water tank back to the dehumidifier. . [Figure 2.3]

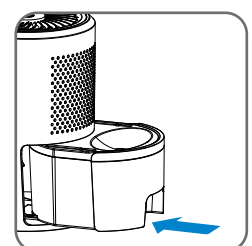

Figure 2.3

CLEANING & CARE

For better performance of the dehumidifier, Arovec recommends to perform basic and deep cleaning of AroDry-900 regularly. Always unplug the dehumidifier before you clean it. DO NOT use any harsh cleaning agents e.g. bleach or alcohol to clean any part of the dehumidifier.

Basic Cleaning:

- It is recommended to perform basic cleaning the dehumidifier every day.
- Drain collected water from the water tank.
- Wipe down the outside of dehumidifier and water tank with a soft and clean cloth.

Deep Cleaning:

- It is recommended to perform deep cleaning the dehumidifier at least once a month and before/after storing it for long periods of time. You should also deep clean if there is any mould or scale build-up inside the water tank.
- Switch off the dehumidifier and remove the water tank.
- Pull out the rubber plug to open the drain hole. Drain the collected water from the water tank.
- Unscrew and remove the water tank cover.
- Wash and clean the water tank and its cover. Then, wipe down and dry the water tank and its cover.
- Leave the empty water tank open for at least one hour to remove any bad smells.
- Screw back the water tank cover and replace back the rubber plug to close the drain hole.
- Put the water tank back to the dehumidifier.

STORAGE

- If not using the dehumidifier for an extended period of time, it's a good idea to clean and wrap the dehumidifier in plastic packaging and store in a dry place to avoid moisture damage.
- Ensure that the dehumidifier is turned off and unplugged.
- Store the dehumidifier in an upright position. Do not store anything on the top of dehumidifier

DISPOSAL



To prevent possible harm to the environment or human health from uncontrolled waste disposal, separate the unneeded dehumidifier and its related accessories from other types of wastes. Ask your local council where to dispose of your dehumidifier and its related accessories. You should not throw your dehumidifier and its related accessories away with the daily normal household waste.

TROUBLESHOOTING

Here are some tips to try if your dehumidifier isn't working properly.

Problem	Possible Cause	Possible Solution
Dehumidifier won't turn on or buttons not working	No electricity.	Check for power.
	The power adapter is not properly plugged in.	Remove and reconnect the power adapter.
	The water tank is full.	Drain the collected water.
Dehumidifier runs but the humidity level does not decrease.	Air inlet or outlet is blocked.	Remove blockage.
	Doors and windows are open, letting in new moisture.	Make sure all doors and windows are closed.
	There are other sources of humidity in the room (e.g. boiling water).	Prevent the humidity sources in the room.
	The temperature in the room is too low.	The dehumidifier is designed to operate between 15°C and 32°C. Moisture removal is greatly reduced if room temperatures exceed this temperature range.
	Insufficient time for the dehumidifier to remove moisture.	After initial operation, allow few hours to maintain desired dryness.
Dehumidifier stopped working and the light is flashing.	The water tanks is full.	Empty the water rank.
Water leaks down on the floor.	The dehumidifier is placed on an uneven surface, so water drips out of the tank.	Place the dehumidifier on an even level surface.
Noise	Fan is working.	Wind from the fan can create sounds during operation. This is normal.

If your problem isn't listed in the above table, please contact customer support at support@arovec.com.au for assistance.

WARRANTY INFORMATION

Arovec dehumidifiers are designed and manufactured to the highest quality standards. Your dehumidifier is covered for 2 year warranty, which includes 1-year standard warranty and 1-additional year, from the date of original purchase.

Product name	Air Dehumidifier
Model	AroDry-900
Standard warranty period	1 Year
Additional warranty	Extend your warranty for 1-additional year. Simply register on to arovec.com.au/warranty within the first 14 days of original purchase.
Record your order details here. This will help if you have any warranty questions in the future.	
Date of original purchase	
Order number	

TERMS AND CONDITIONS

In addition to your rights under the Arovec warranty, you are also covered by guarantees under Australian Customer Law. The Arovec warranty is only available in Australia.

In Australia our goods come with guarantees that cannot be excluded under the Australian Customer Law. You are entitled to replacement or refund for a major failure and compensation for any other reasonably foreseeable loss or damage. You are also entitled to have the goods repaired or replaced if the goods fail to be of acceptable quality and failure does not amount to a major failure.

What is Covered

- The repair or replacement of your Arovec dehumidifier (at Arovec's discretion) if the product is found to be defective due to faulty manufacture. Arovec reserves the right to determine if the fault requires a replacement or repair.
- Packaging and instructions of a faulty dehumidifier may also be replaced if damaged.
- This warranty is valid for using your dehumidifier within Australia.
- This warranty is valid for personal use only.
- Warranties are limited to the 2 year (1-year standard and 1-additional year) from the date of original purchase.

What is Not Covered

- Using your dehumidifier for commercial purposes or anything other than normal domestic use.
- Using your dehumidifier outside of Australia.
- Accidental damage or faults caused by neglect, misuse, vandalism and abuse.
- Damage or faults caused by not following the instructions in this user manual.
- Unsupervised use by children under the age of 18.
- Repairs or alterations carried out by parties other than Arovec or an authorised agent.
- All other conditions that are not covered by Arovec warranty as listed in the “What is Covered” section.

This warranty is not transferable.

Arovec is not responsible or liable for any damages, losses or inconveniences caused by product failure or accidental damage or faults caused by not following the instructions or safety warnings contained in this User Manual.

Please email at support@arovec.com.au with any further inquiries about Arovec warranty or to ask about making a warranty claim. You must contact us within your warranty period for your claim to be eligible.

DEFECTIVE PRODUCTS & RETURNS

Once your product proved as a defective within the specified warranty period, stop using it and contact customer support at support@arovec.com.au with your order number.

CUSTOMER SUPPORT - AUSTRALIA

Please contact customer support with any questions regarding your product. Feel free to contact our helpful customer support team. Your satisfaction is our priority.

Customer Support:

Yasin Pty Ltd.

PO Box 2, Ermington NSW 1700, Australia

www.arovec.com.au

support@arovec.com.au

Please provide your order number when you contact customer support.



www.arovec.com.au