

USER MANUAL



Smart True HEPA Air Purifier

Model: AV-P152PRO



This manual provides safety and operating instructions.
Please read this manual thoroughly before using the product.
This manual will help get your air purifier going in just a few quick minutes.

TABLE OF CONTENTS

Important Safety Instructions	4
Introduction	5
Getting to Know Your Air Purifier	6
Before Using For The First Time	7
General Tips	8
Operation	9
Replacing The Filter	12
Cleaning & Care	15
Storage, Disposal	15
Troubleshooting	16
Warranty Information	17
Defective Products & Returns	18
Customer Support - Australia	18

PACKAGE CONTENTS

1 x AV-P152PRO Smart True HEPA Air Purifier
1 x Filter Package (Pre-fitted in Air Purifier)
1 x User Manual
1 x Warranty Card

PRODUCT SPECIFICATION

Power Supply	220V - 240V , 50Hz
Rated Power	23W
Effective Range	Areas up to 45 m ² (485 ft ²)
Operating Conditions	Temperature: -10°C to 40°C Relative Humidity: < 85% RH
Noise Level	29 - 52dB
Standby Power	< 0.8W
Weight	2.9kg
Dimensions	ø 22.8 × H40.0cm
CADR (smoke)	250m ³ /h
Filter Pack	4-Layered Filtration System: 1. Preliminary Filter 2. True HEPA Filter 3. Activated Carbon Filter 4. Polypropylene Net

THANK YOU FOR CHOOSING TO BUY AN AROVEC AIR PURIFIER

We are here to help you with any questions.
Customer Support - AUSTRALIA

- 🌐 www.rovec.com.au
- ✉ support@rovec.com.au
- 📷 @aroveclifestyle

IMPORTANT SAFETY INSTRUCTIONS

Please read all instructions before use to prevent the risk of injury, fire, electric shock or damage. Use your air purifier safely by following the instructions in this User Manual.

- **DO NOT** use the air purifier before removing the plastic packaging from the filter. It is a fire hazard to use your air purifier with the filter still inside its packaging.
- **DO NOT** use the air purifier if it has been dropped, damaged, left outside, dropped in water, or not working properly.
- **DO NOT** use the air purifier if the cord or plug looks damaged.
- **DO NOT** use the air purifier near gas appliances, fire places, stoves, candles, or heating devices.
- **DO NOT** use the air purifier in an area with insect repellents, burning incense, toxic fumes, flammable dust or oxygen tanks. Always leave at least 1.5m of clear space from any oxygen being administered.
- **DO NOT** touch any part of the air purifier or its plug with wet hands.
- **DO NOT** run the power cord under furniture, other appliances, carpet, or cover with rugs, runners or floor coverings.
- **ALWAYS** tuck away the power cord to prevent tripping accidents.
- **DO NOT** put the air purifier on an unstable surface e.g. bed or couch.
- **DO NOT** use the air purifier and power plug on wet or damp surfaces.
- **DO NOT** put the air purifier in water or liquids.
- **DO NOT** keep air purifier under an air conditioner to help prevent moisture getting into the unit.
- **DO NOT** use the air purifier outdoor.
- **DO NOT** use the air purifier in a room that can have a big change in temperature. This will help minimise the risk of condensation.
- **DO NOT** put fingers or any objects into the air inlet/outlet of the air purifier.
- **DO NOT** use a defective air purifier or attempt to repair/adjust any electrical or mechanical functions, this may cause danger and void the warranty.
- **DO NOT** let children or people with reduced physical or mental capabilities to use or clean the air purifier.
- **DO NOT** let children play with this appliance or its packaging including plastic bag. Children must be supervised around the air purifier to help keep them safe.
- **DO NOT** sit on the air purifier or put any objects on top of the unit.
- **DO NOT** block/obscure the air inlet or outlet. Keep free of anything that could reduce airflow.
- **DO NOT** spray air fresheners, perfumes or oils on or near the filter.
- **DO NOT** fit the air purifier with a different power supply unit.
- **DO NOT** clean the air purifier or change the filter with the power cord plugged in.
- **DO NOT** use the air purifier for commercial purposes. This appliance is for household use only.
- It is recommended to NOT use the unit with an extension cord to avoid electrical shock or spark.
- **TURN OFF** the air purifier when it is not being used. Hold the plug and remove it from the electrical source. Do not unplug by pulling the cable.
- **WARNING:** This air purifier does not remove carbon monoxide or radon from the air. It must not be used to prevent or clean up accidents with combustion processes and hazardous chemicals.

KEEP THESE INSTRUCTIONS IN A SAFE PLACE.

INTRODUCTION

The AV-P152PRO True HEPA air purifier removes contaminants from the air to improve indoor air quality. Be aware of the real-time air quality changes of your room with help of air quality sensor in the AV-P152PRO.

Arovec AV-P152PRO air purifier uses a system of internal fan to pull the air in your room through a high efficiency filtration system that removes harmful airborne particles like dust, pollen and bacteria. Keep your environment healthy with AV-P152PRO.

PRODUCT FEATURES

Smart Sensor & Auto-Mode: The smart air quality sensor in this air purifier intelligently detects PM2.5 levels and the purification speed automatically adjust accordingly in Auto-Mode to effectively deal with the pollution level.

Peaceful Sleep: Have an undisturbed deep sleep while the air purifier is quietly operating in Sleep-Mode. You can also turn off the display and light for a dark sleeping environment.

High Efficiency Filtration System: This air purifier uses multiple stage filtration system, which removes 99.97% of air pollutants including particulate matters PM2.5, dust, pollen, odour, allergens, smoke, and bacteria.

1. Preliminary Filter: Captures large particles such as dust, pet dander and hair.
2. True HEPA Filter: Removes fine particles such as PM2.5, dust mites, allergens, airborne bacteria and pollen.
3. High-Efficiency Activated Carbon Filter: Removes various odours and smokes such as cigarette smoke, cooking smell and pet odours.
4. Polypropylene Net: Extra protection of Activated Carbon Filter.

GETTING TO KNOW YOUR AIR PURIFIER

- | | |
|---|------------------------------|
| 1. Fan Speed Indicators | 11. Air Outlet |
| 2. Fan Speed Button | 12. Dust Sensor |
| 3. Auto Mode Button | 13. Air Inlet |
| 4. Timer Button | 14. Power Cord |
| 5. Timer Indicators | 15. Base Cover |
| 6. Sleep Mode Button | 16. Filter Pack |
| 7. Filter Change Indicator | 16.a Preliminary Filter |
| 8. Power Button | 16.b True HEPA Filter |
| 9. Air Quality Light / Display-off Button | 16.c Activated Carbon Filter |
| 10. Air Quality Light / Night Light | 16.d Polypropylene Net |

Top View

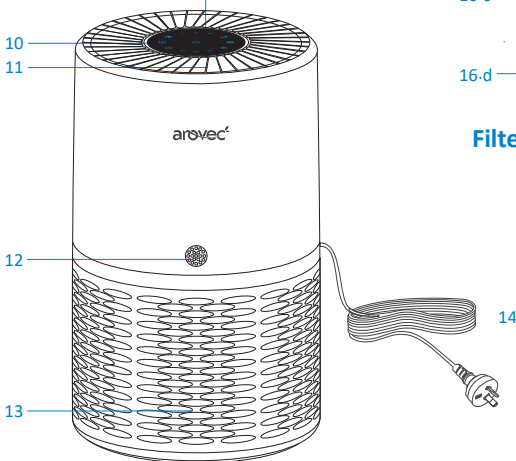
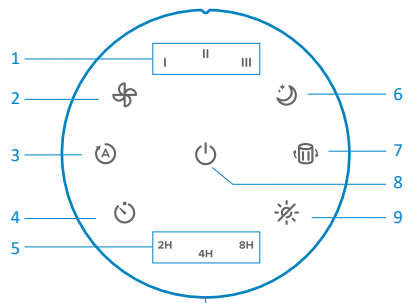

Front View

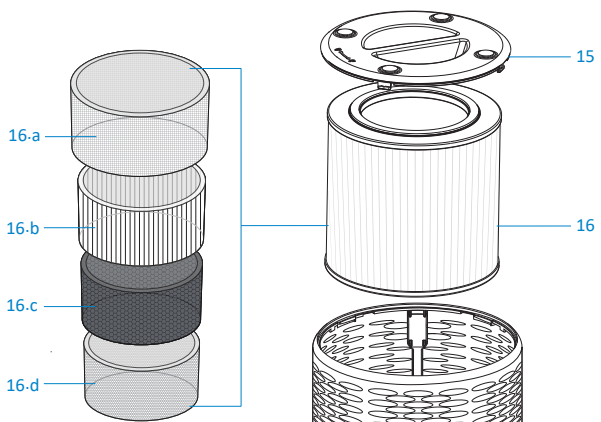

Filter Internal Details

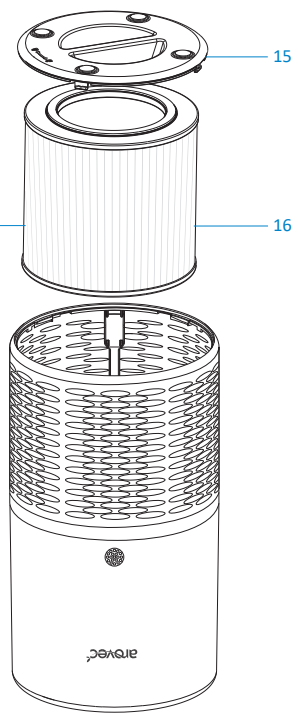

Upside Down View

BEFORE USING FOR THE FIRST TIME

The air purifier comes with the filter fitted inside, but they are packaged in plastic. You **MUST** remove the filter from its packaging before turning the air purifier on.

1. Turn the air purifier upside down on a soft cloth. [Figure 1.1]
2. Turn the base cover anticlockwise to unlock the cover. [Figure 1.1]
3. Remove the base cover. [Figure 1.2]
4. Remove the filter from the air purifier. [Figure 1.2]

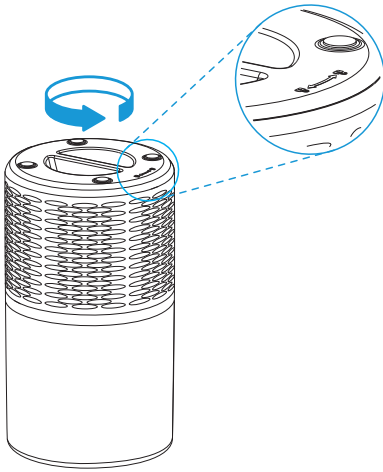

Figure 1.1

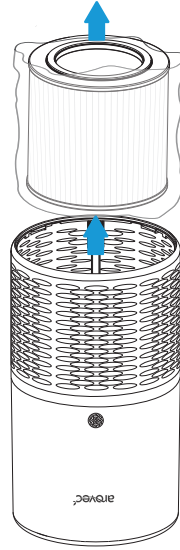

Figure 1.2

5. Remove the filter from its packaging. [Figure 1.3]

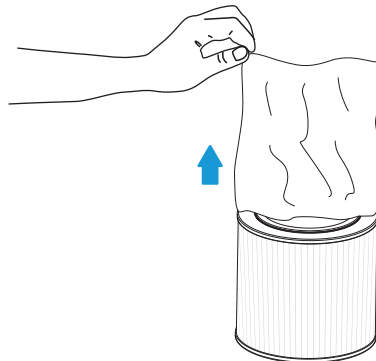

Figure 1.3

6. Put the filter back into the air purifier. [Figure 1.4]

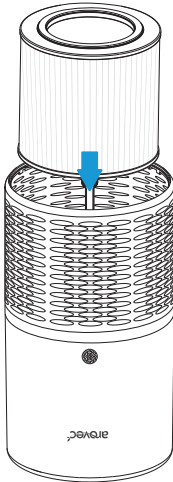

Figure 1.4

7. Put the base cover back on and turn it clockwise to the lock cover. [Figure 1.5]

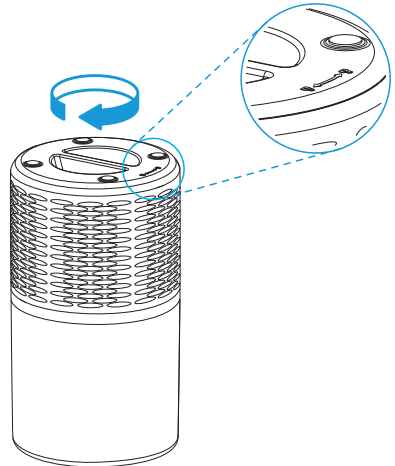

Figure 1.5

GENERAL TIPS

- The air purifier should be on a flat, level surface, with the control panel facing up before switching it on. [Figure 2.1]
- Leave at least 40 cm of clear space around each side of the air purifier when it is on. [Figure 2.1]

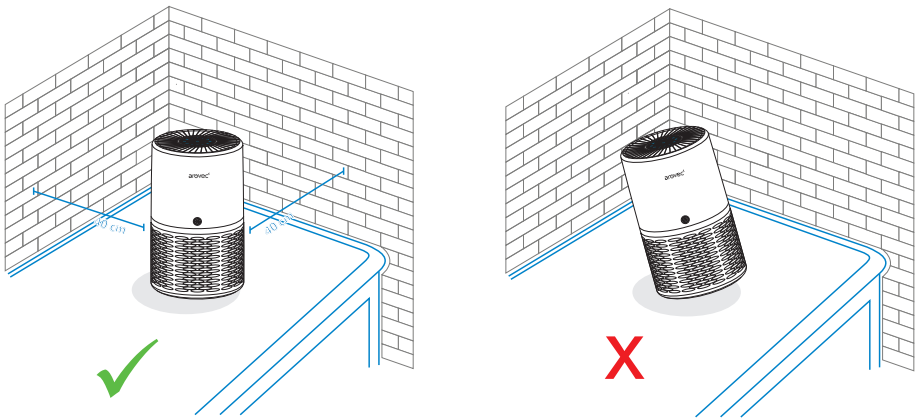
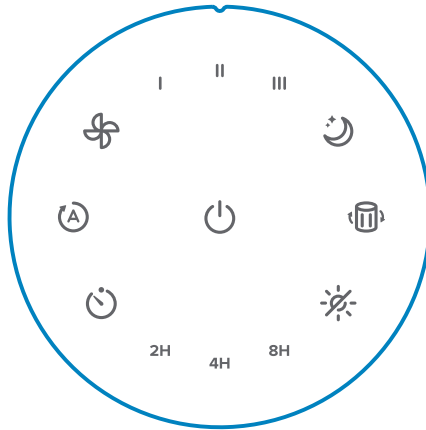

Figure 2.1

- Shut nearby windows when the air purifier is on to help clean the air.
- For best results, use the purifier for 15-20 minutes at the maximum fan speed, then adjust the fan speed as required.

OPERATION

Plug the air purifier into an electrical outlet.



POWER Button:

- Tap () once to turn the air purifier on or off.



FAN SPEED Button:

- There are 3 fan-speed options: 1 (low), 2 (medium), and 3 (high).
- Each tap will toggle to the next fan speed level.

Memory Function:

- The air purifier keeps the control settings when it is turned off. When the air purifier is plugged in it will remember its previous fan speed setting.
- The fan speed level will return to the previous setting when the air purifier is turned back on.
- Please note that the air purifier must remain plugged in for this memory function to work.



SLEEP MODE Button:





- In sleep mode, the air purifier runs quietly on lowest fan speed and all indicators turn off except sleep and power indicators.
- Tap (🌙) to enter the sleep mode.
- When the air purifier is running in sleep mode, the timer and air quality light can be controlled independently by their related buttons.
- To end the sleep mode tap (🌙) or (🌀).



AIR QUALITY LIGHT / DISPLAY-OFF Button:

- The LED light indicates air quality in 4 different colours. [Table 1]

[Table 1]



Air Quality Indicator Table	
Colour	Air Quality
Blue 	Very Good
Green 	Good
Orange 	Moderate
Red 	Bad

Note: It will take 1 minute for the dust sensor to detect the air quality after the Air Purifier turned on.





- Tap once the (🌞) to turn on or off the AQ-light and indicators.
- When the air purifier is running, the LED light colour will change according to the detected air quality.



AUTO MODE Button:

- The () denotes for auto mode. Tap () to activate the auto mode.
- In auto mode, the air quality light changes its colour based on detected air quality and fan speed adjusts accordingly. [Table 2]

[Table 2]

Auto Mode Setting		
Colour	Air Quality	Fan Speed
Blue 	Very Good	Sleep Mode
Green 	Good	1 (low)
Orange 	Moderate	2 (med)
Red 	Bad	3 (high)





Note: It will take 1 minute for the dust sensor to detect the air quality after the Air Purifier turned on.



TIMER Button:

- You can set a timer for 2, 4, or 8 hours. [Table 3]
- Tap () repeatedly to select a time.



[Table 3]

Timer Setting Table				
Tap () repeatedly to select a time	1 st Tap ()	2 nd Tap ()	3 rd Tap ()	4 th Tap ()
Indicator light up	2H	4H	8H	All timer indicators turn off
Selected time	2 hours	4 hours	8 hours	Timer cancelled

- The air purifier will automatically turn off once the timer is finished.
- If no timer is set, the air purifier will continuously operate until it is manually turned off.
- To cancel the timer, tap () until all timer indicators turn off.



FILTER CHANGE Button:

- The () indicator will light up to remind you to replace the filter.
- Tap and hold the () for 3-5 seconds to reset the air purifier after replacing the filter.

REPLACING THE FILTER

The () will light up to remind you to replace the filter.

DO NOT wash or reuse the filter. Only use original Arovec AV-P152PRO-RF replacement filter when changing the filter is required. This will help your air purifier to work effectively and last longer.

Replacement filter is available at www.ovec.com.au

When to Replace the Filter:

- It's best to change the filter every 4-5 months (3000 hours used). You may need to change the filter more often or less often, depending on how much you use your air purifier and on how much pollution is in the air.
- You don't need to wait for the () to turn on for changing the filter. You may need to change the filter if you notice any of the following:
 - Increased noise from the air purifier when it's switched on.
 - No effective difference in air quality.
 - Decreased airflow.
 - Unusual odours.
 - Clogged filter.

Steps for Replacing the Filter:

Follow these steps to replace the filter:

1. Turn off and unplug the air purifier.
2. Turn the air purifier upside down on a soft cloth. [Figure 3.1]
3. Turn the base cover anticlockwise to unlock the cover. [Figure 3.1]
4. Remove the base cover. [Figure 3.2]
5. Remove the used filter from the air purifier. [Figure 3.2]

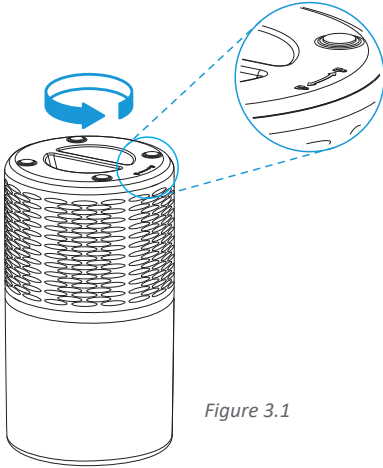

Figure 3.1

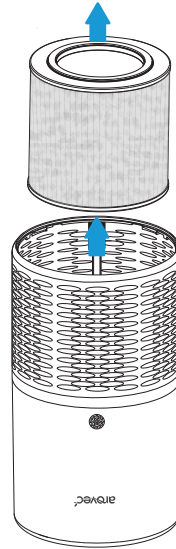

Figure 3.2

6. Clean any remaining dust or hair inside the air purifier with a vacuum cleaner. DO NOT use water or any liquids to clean the air purifier. [Figure 3.3]
7. Remove the new filter from its packaging. [Figure 3.4]

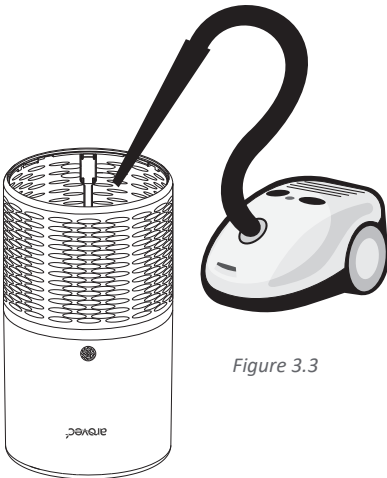

Figure 3.3

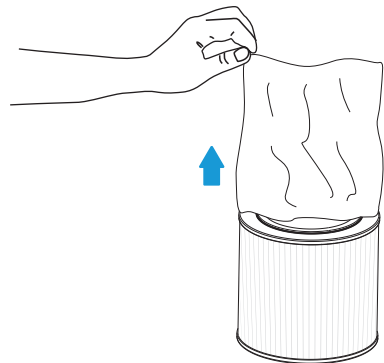

Figure 3.4

8. Place the new filter into the air purifier. [Figure 3.5]

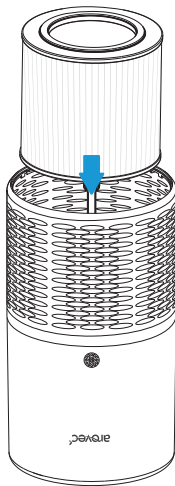

Figure 3.5

9. Put the base cover back on and turn it clockwise to lock the cover. [Figure 3.6]

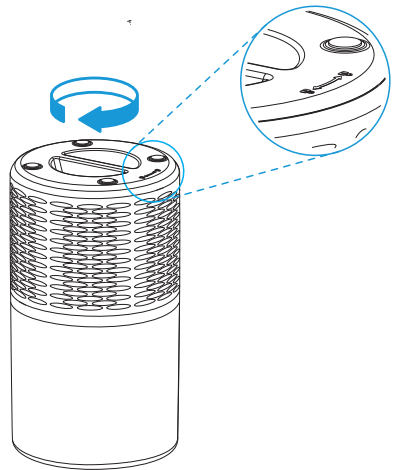









Figure 3.6

Resetting the Air Purifier After Filter Replacement:

You need to reset the air purifier in two conditions.

1. If the filter was replaced after the () light up:
 - Turn on the air purifier.
 - Press and hold () for 3-5 seconds.
 - The () light should turn off, which indicates that the air purifier has been reset.
 - You can use the air purifier with the new filter.
2. If the filter was replaced before the () light up:
 - Plug in the air purifier after filter replacement, but do not turn on the air purifier.
 - Press and hold () for 3-5 seconds, to light up the ().
 - Press and hold again () for 3-5 seconds, to turn off the (), the reset is now complete.
 - You can turn on and use the air purifier with the new filter.

CLEANING & CARE

- Unplug the air purifier before you clean it.
- Wipe down the outside of air purifier regularly with a soft and clean cloth.
- **DO NOT** use any harsh cleaning agents e.g., bleach or alcohol to clean any part of the air purifier.

Cleaning the filter

- To increase the efficiency and life of the filter, clean it at least once a month using a soft brush or vacuum cleaner to remove large particles, hair and dust. Do not wash or clean the filter with water or any other liquids. [Figure 4.1]

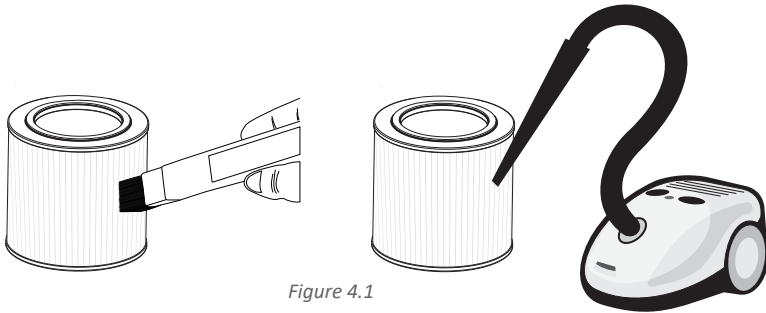

Figure 4.1

STORAGE







- If not using the air purifier for an extended period of time, it is a good idea to wrap both the air purifier and the filter in plastic packaging and store in a dry place to avoid moisture damage.
- Ensure that the air purifier is powered off by removing the power plug from the power outlet.
- Store the air purifier in an upright position. Do not store anything on the top of air purifier.

DISPOSAL

Ask your local council where to dispose of your air purifier and its filter. You should not throw your air purifier and its filter away with the daily normal household waste.

TROUBLESHOOTING

Here are some tips to try if your air purifier isn't working properly.

Problem	Possible Solution
Air purifier won't turn on or buttons not working	Plug into a powered electrical outlet.
	Try plugging the air purifier into a different outlet.
	Air purifier or the cord might be damaged.
	If these solutions don't work, DO NOT use the air purifier.
Air purifier makes an unusual noise	Ensure that the filter is removed from its packaging.
	Ensure that the filter is placed correctly as described in this user manual.
	Replace the filter.
	Check the air purifier is on a hard, flat and dry surface.
	Air purifier might be damaged or have a foreign object stuck inside.
Significantly reduced airflow	If these solutions don't work, DO NOT use the air purifier and DO NOT try to fix the problem.
	Ensure that the filter is removed from its packaging.
	Press () to increase the fan speed.
	Replace the filter.
The () indicator light is still on after changing the filter	Check there is at least 40 cm of free space around the air purifier on each side.
	Tap and hold the () for 3-5 seconds. The () indicator light should turn off to indicate that the air purifier has been reset.
	The () indicator light might not turn on if you haven't used your air purifier often in the past 6 months.
The () indicator light hasn't turned on in 6 months	You may need to change the filter more often or less often, depending on how much you use your air purifier and on how much pollution is in the air.
There is a strange smell when the air purifier is on	Check if the filter need to be replaced.
	Ensure that the area is not humid or there aren't any essential oils or perfumes in the area.
	Air Purifier might be damaged.
The air purification quality is low	Press () to increase the fan speed.
	The air purifier is effective in areas up to 45 m ² .
	Remove any debris blocking the airflow (inlet and outlet) of the air purifier.
	Ensure that the doors and windows are closed.
	Check if the filter need to be replaced.

If your problem isn't listed in the above table, please contact customer support at support@arovec.com.au for assistance.

WARRANTY INFORMATION

Arovec air purifiers are designed and manufactured to the highest quality standards. Your air purifier is covered for parts and labour (excluding filters) for 2 year, which includes 1-year standard warranty and 1-additional year, from the date of original purchase.

Product name	Smart True HEPA Air Purifier
Model	AV-P152PRO
Standard warranty period	1 Year
Additional warranty	Extend your warranty for 1-additional year; Simply register on to arovec.com.au/warranty within the first 14 days of your purchase.
Record your order details here. This will help if you have any warranty questions in the future.	
Date of original purchase	
Order number	

TERMS AND CONDITIONS

In addition to your rights under the Arovec warranty, you are also covered by guarantees under Australian Consumer Law. The Arovec warranty is only available in Australia.

In Australia our goods come with guarantees that cannot be excluded under the Australian Consumer Law. You are entitled to a replacement or refund for a major failure and compensation for any other reasonably foreseeable loss or damage. You are also entitled to have the goods repaired or replaced if the goods fail to be of acceptable quality and the failure does not amount to a major failure.

What is Covered:

- The repair or replacement of your Arovec air purifier (at Arovec's discretion) if the product is found to be defective due to faulty manufacture. Arovec reserves the right to determine if the fault requires a replacement or repair.
- Packaging and instructions of a faulty air purifier may also be replaced if damaged.
- This warranty is valid for using your air purifier within Australia.
- This warranty is valid for personal use only.
- Warranties are limited to the 2 year (1-year standard and 1-addtional year) from the date of original purchase.

What is Not Covered:

- Replacement filters are not included in warranty.
- Using your air purifier for commercial purposes, or anything other than normal domestic use.
- Using your air purifier outside of Australia.
- Accidental damage or faults caused by neglect, misuse, vandalism and abuse.
- Accidental damage or faults caused by not following the instructions or safety warnings contained in this User Manual.
- Unsupervised use by children under the age of 18.
- Repairs or alterations carried out by parties other than Arovec or an authorised agent.
- Damage caused by using filters other than original Arovec replacement filters.
- All other conditions that are not covered by Arovec warranty as listed in the “What is Covered” section.

This warranty is not transferrable.

Arovec is not responsible or liable for any damages, losses or inconveniences caused by product failure or accidental damage or faults caused by not following the instructions or safety warnings contained in this User Manual.

Please email at support@arovec.com.au with any further inquiries about Arovec warranty or to ask about making a warranty claim. You must contact us within your warranty period for your claim to be eligible.

DEFECTIVE PRODUCTS & RETURNS

Once your product proved as a defective within the specified warranty period, stop using it and contact customer support at support@arovec.com.au with your order number.

CUSTOMER SUPPORT - AUSTRALIA

Please contact customer support with any questions regarding your product. Feel free to contact our helpful customer support team. Your satisfaction is our priority.

Customer support:

Yasin Pty Ltd.

PO Box 2, Ermington 1700, NSW Australia

www.arovec.com.au

support@arovec.com.au

Please provide your order number when you contact customer support.



www.arovec.com.au