

## **True HEPA Air Purifier**

**Model: AV-P152, AV-P152B**

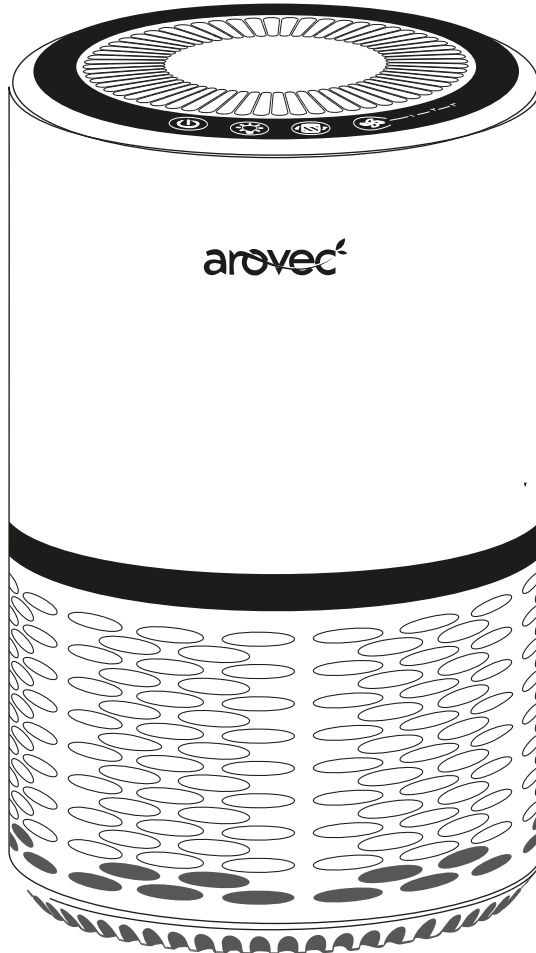

This manual provides safety and operating instructions.  
Please read this user manual thoroughly before using the product.  
This manual will help get your air purifier going in just a few quick minutes.



## TABLE OF CONTENTS

Important Safety Instructions	4
Introduction	5
Getting to Know Your Air Purifier	6
Before Using For The First Time	7
General Tips	9
Operation	10
Replacing The Filters	11
Cleaning & Care	14
Storage	14
Disposal	14
Troubleshooting	15
Warranty Information	16
Customer Support- Australia	20

## PACKAGE CONTENTS

1 × H13 True HEPA Air Purifier
1 × Preliminary Filter (Pre-fitted)
1 × Activated Carbon and HEPA Filter (pre-fitted)
1 × User Manual
1 × Warranty Card

## PRODUCT SPECIFICATION

Power Supply	220 V- 240 V ,50 Hz
Rated Power	25 W
Effective Range	Areas up to 15 m <sup>2</sup>
Operating Conditions	Temperature: -10 °C to 40 °C
Noise Level	28-50 dB
Standby Power	< 0.8 W
Weight	2.5 kg
Dimensions	∅ 20 × H 32 cm
CADR (smoke)	100 m <sup>3</sup> /h
Filters	Preliminary Filter H13 True HEPA Filter Activated Carbon Filter

## THANK YOU FOR CHOOSING TO BUY AN AROVEC AIR PURIFIER

We are here to help you with any questions.  
Customer Support- AUSTRALIA

- 🌐 [www.rovec.com.au](http://www.rovec.com.au)
- ✉ [support@rovec.com.au](mailto:support@rovec.com.au)
- 📷 [@roveclifestyle](https://www.instagram.com/roveclifestyle)

## IMPORTANT SAFETY INSTRUCTIONS

Please read all instructions before use to reduce the risk of injury, fire, electric shock or damage. Use your purifier safely by following the instructions in this manual.

- DO NOT use the air purifier before removing the plastic packaging from the filter. It is a fire hazard to use your air purifier with the filter still inside its packaging.
- DO NOT use the air purifier if it has been dropped, damaged, left outside, dropped in water, is defective or not working properly.
- DO NOT use the air purifier if the cord or plug looks damaged.
- DO NOT use the air purifier near gas appliances, fire places, stoves, candles, or heating devices.
- DO NOT use the air purifier in an area with insect repellents, burning incense, toxic fumes, flammable dust or oxygen tanks. Always leave at least 1.5 m of clear space from any oxygen being administered.
- DO NOT touch any part of the air purifier or its plug with wet hands.
- DO NOT run the power cord under furniture, other appliances, carpet, or cover with rugs, runners or floor coverings.
- ALWAYS tuck away the power cord to prevent tripping accidents.
- DO NOT use the air purifier and power plug on wet or damp surfaces.
- DO NOT put the air purifier in water or liquids.
- DO NOT use the air purifier outdoor.
- DO NOT keep air purifier under an air conditioner to help prevent moisture getting into the unit.
- DO NOT use the air purifier in a room that can have a big change in temperature. This will help minimise the risk of condensation.
- DO NOT put fingers or any objects into the air inlet/outlet of the air purifier.
- DO NOT use a defective air purifier or attempt to repair/adjust any electrical or mechanical functions, this may cause danger and void the warranty.
- DO NOT let children or people with reduced physical or mental capabilities to use or clean the air purifier.
- DO NOT let children play with this appliance or its packaging including plastic bag. Children must be supervised around the air purifier to help keep them safe.
- DO NOT sit on the air purifier or put any objects on top of the unit.
- DO NOT block/obscure the air inlet or outlet. Keep free of anything that could reduce airflow.
- DO NOT fit the air purifier with a different power supply unit.
- DO NOT spray air fresheners, perfumes or oils on or near the filter.
- DO NOT clean the air purifier or change the filter with the power cord plugged in.
- DO NOT use the air purifier for commercial purposes. This appliance is for household use only.
- It is recommended to NOT use the unit with an extension cord to avoid electrical shock or spark.
- TURN OFF the air purifier when it is not being used. Hold the plug and remove it from the electrical source. Do not unplug by pulling the cable.
- **WARNING:** This air purifier does not remove carbon monoxide or radon from the air. It must not be used to prevent or clean up accidents with combustion processes and hazardous chemicals.

KEEP THESE INSTRUCTIONS IN A SAFE PLACE

# INTRODUCTION

The AV-P152 H13 True HEPA air purifier removes contaminants from the air to improve indoor air quality.

Arovec AV-P152 H13 True HEPA air purifier uses a system of internal fan to pull the air in your room through a high efficiency filtration system that removes harmful airborne particles.

Keep your environment healthy with AV-P152 H13 True HEPA air purifier.

## Product Features

**Peaceful Sleep:** Have an undisturbed deep while the air purifier is quietly operating. You can also turn OFF the display and light for a dark sleeping-environment.

**High Efficiency Filtration System:** This air purifier uses multiple stage filtration system, which removes 99.97% of air pollutants including particulate matters PM2.5, dust, pollen, odour, allergens, smoke, and bacteria.

- 1. Preliminary Filter:** Captures large particles such as dust, pet dander and hair.
- 2. H13 True HEPA Filter:** Removes fine particles such as PM2.5, dust mites, allergens, airborne bacteria and pollen.
- 3. High-Efficiency Granular Activated Carbon Filter:** Removes various odours and smokes such as cigarette smoke, cooking smell and pet odours.

# Getting to Know Your Air Purifier

1. LED Night Light
2. Air Outlet
3. Power Button
4. Night Light Button
5. Filter Reset Button
6. Fan Speed Button
7. Fan Speed Indicator
8. Upper Body
9. Power Cord
10. Air Inlet
11. Base Cover
12. Preliminary Filter
13. H13 True HEPA Filter
14. Activated Carbon Filter

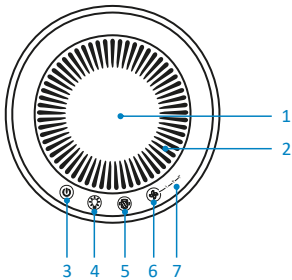

Top View

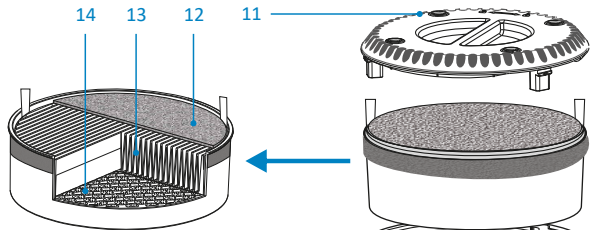

Filters Internal Details

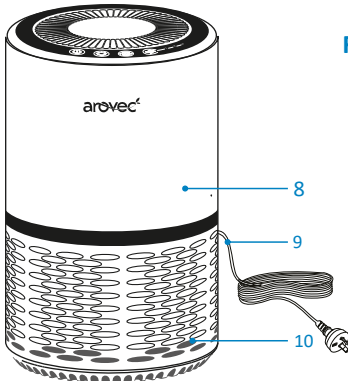

Front View

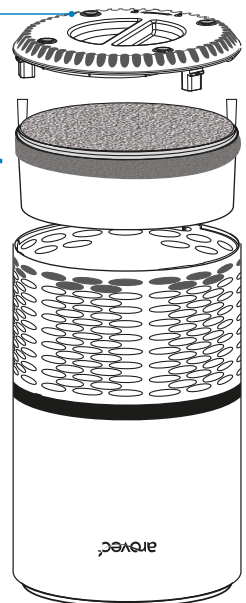

Upside Down View

## BEFORE USING FOR THE FIRST TIME

The air purifier comes with the filters fitted inside, but they are packaged in plastic. You must remove the filters from their packaging before turning the air purifier on.

1. Turn the air purifier upside down on a soft cloth. [Figure 1.1]
2. Turn the base cover anticlockwise to unlock the cover. [Figure 1.1]
3. Remove the base cover. [Figure 1.2]
4. Remove the filters from the air purifier. [Figure 1.2]

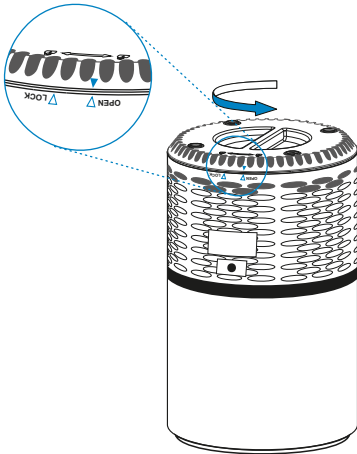

Figure 1.1

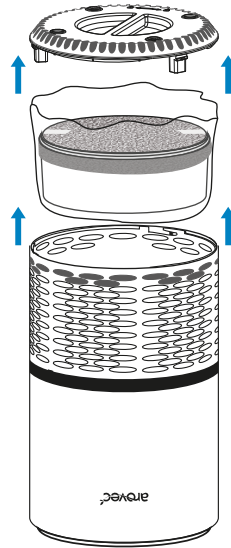

Figure 1.2

5. Remove the filters from the packaging. [Figure 1.3]

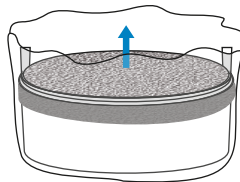

Figure 1.3

6. Put the filters back into the air purifier.

[Figure 1.4]

- Make sure the grey pre-filter is on top of the white HEPA filter.
- Make sure the white tabs are pointing upward.

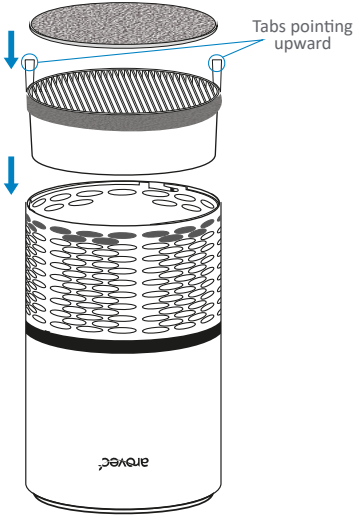

Figure 1.4

7. Put the base cover back on. [Figure 1.5]

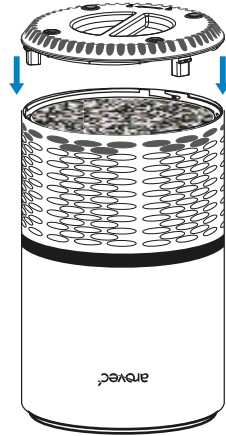

Figure 1.5

8. Turn the base cover clockwise to the lock position. [Figure 1.6]

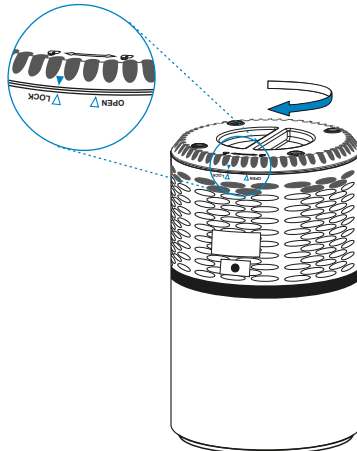

Figure 1.6



## GENERAL TIPS

- The air purifier should be on a flat, level surface, with the night light facing up before switching it on. [Figure 2.1]
- Leave at least 40 cm of clear space around each side of the air purifier when it is turned on. [Figure 2.1]

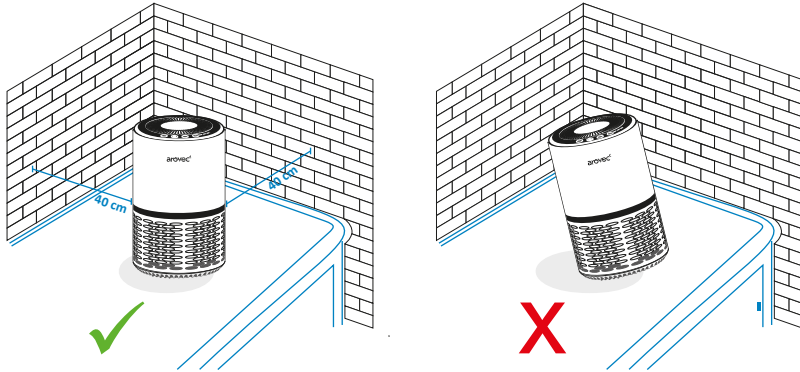

Figure 2.1

- Shut nearby windows when the air purifier is turned on to help clean the air.
- For best results, use the purifier for 15-20 minutes at the maximum fan speed, then adjust the fan speed as required.

# OPERATION

Plug-in the air purifier into an electrical outlet.

## CONTROL PANEL:





### Power Button:

- Tap (  ) once to turn the air purifier ON or OFF.





### Night Light Button:

- Tap (  ) to adjust the brightness or turn OFF the night light.
- Each tap will toggle to the next setting, ON → DIM → OFF → ON.
- Tap and hold (  ) for 3-5 seconds to turn OFF all the buttons indicators and lights.
- The light can be used as a sleep-light with blue colour even if the air purifier is not running.



### Filter Change Button:

- The (  ) will light up to remind you to replace the filters.
- Tap and hold the (  ) for 3-5 seconds after replacing the filters.
- The (  ) indicator light will turn off after successfully filter reset.



### Fan Speed Button:

- There are 3 fan speeds: 1 (low), 2 (medium) and 3 (high).
- Each tap will toggle to the next fan speed level.



### Memory Function:

- The air purifier keeps the control settings when it's turned OFF.
- The fan speed level will return to the previous setting when the air purifier is turned back on.
- Please note that the air purifier must remain plugged in for this memory function to work.

## REPLACING THE FILTERS

The (  ) will light up to remind you to replace the filters.

DO NOT wash/clean or reuse the filters. Only use Arovec AV-P152RF replacement filters when changing the filters are required. This will help your air purifier to work effectively and last longer.

Replacement filters are available at [www.arovec.com.au](http://www.arovec.com.au)  
OR scan the QR Code.



### When to Replace the Filters:

- It's best to change the filters every 6 months (4320 hours). You may need to change the filters more often or less often, depending on how much you use your air purifier and on how much pollution is in the air.
- You don't need to wait for the (  ) to turn on for changing the filters. You may need to change the filters if you notice any of the following:
  - Increased noise from the purifier when it's switched ON.
  - No effective difference in air quality.
  - Decreased airflow.
  - Unusual odours.
  - Clogged filters.

## Steps for Replacing the Filters:

Follow these steps to replace the filters:

1. Turn OFF and unplug the air purifier.
2. Turn the purifier upside down on a soft cloth. [Figure 3.1]
3. Turn the base cover anticlockwise to unlock the cover. [Figure 3.1]
4. Remove the base cover. [Figure 3.2]
5. Remove the used filters. [Figure 3.2]

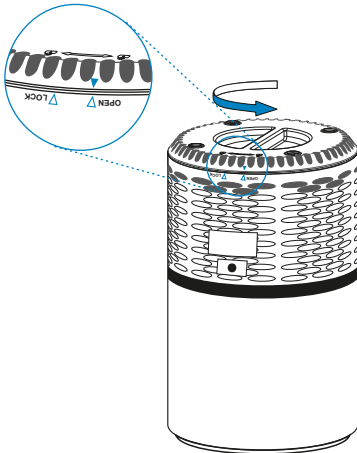

Figure 3.1

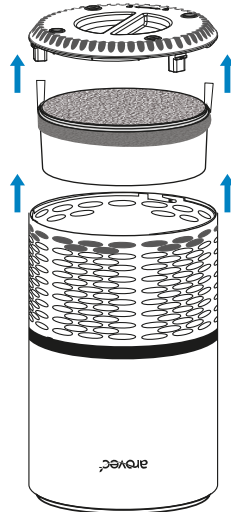

Figure 3.2

6. Clean any remaining dust or hair inside the purifier with a vacuum cleaner. DO NOT use water or any liquids to clean the air purifier. [Figure 3.3]
7. Remove the new filters from their packaging. [Figure 3.4]
8. Place the new filters into the purifier. [Figure 3.5]
  - Make sure the grey pre-filter is on top of the white HEPA filter.
  - Make sure the white tabs are pointing upward.

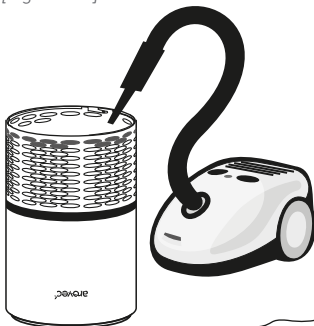

Figure 3.3

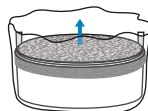

Figure 3.4

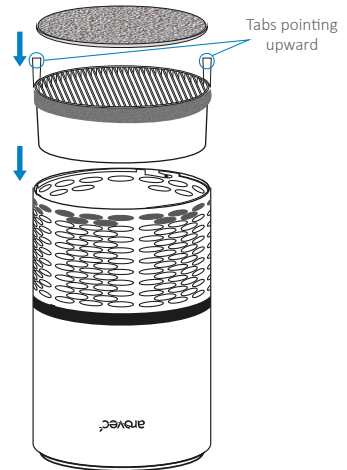

Figure 3.5

9. Put the base cover back on. [Figure 3.6]

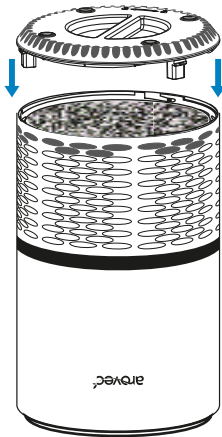

Figure 3.6

10. Turn the base cover clockwise to the lock position. [Figure 3.7]

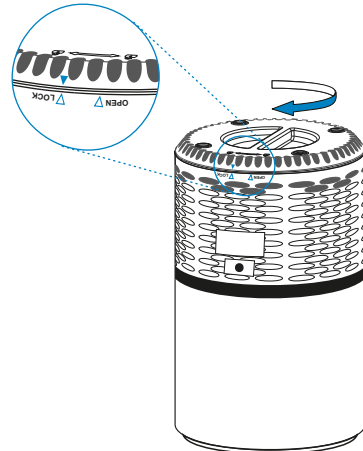









Figure 3.7

## Resetting the Air Purifier After Filters Replacement:

You will need to reset the air purifier in two conditions.

1. If the filters were replaced after the (  ) light up:
  - Turn on the air purifier.
  - Press and hold (  ) for 3-5 Seconds.
  - The (  ) light should turn off, which indicates that the purifier has been reset.
2. If the filters were replaced before the (  ) light up:
  - Plug in the air purifier after filters replacement, but do not turn on the air purifier.
  - Press and hold (  ) for 3-5 Seconds, to light up the (  ) .
  - Press and hold again (  ) for 3-5 seconds, to turn off the (  ) , the reset is now complete.
  - You can turn on and use the air purifier with the new filter.

## CLEANING & CARE



- Unplug the air purifier before you clean it.
- Wipe down the outside of purifier regularly with a soft and clean cloth.
- **DO NOT** use any harsh cleaning agents e.g., bleach or alcohol to clean any part of the air purifier.

## STORAGE



- If not using the air purifier for an extended period of time, It is a good idea to wrap both the air purifier and the filters in plastic packaging and store in a dry place to avoid moisture damage.
- Ensure the air purifier is powered OFF by removing the power plug from the power outlet.
- Store the air purifier in an upright position. Do not store anything on the top of air purifier.







## DISPOSAL



To prevent possible harm to the environment or human health from uncontrolled waste disposal, separate the unneeded air purifier and its related accessories from other types of wastes. Ask your local council where to dispose of your air purifier and its related accessories. You should not throw your air purifier and its related accessories away with the daily normal household waste.

## TROUBLESHOOTING

Here are some tips to try if your air purifier isn't working properly.

Problem !	Possible Solution ✓
<b>Air purifier won't turn on or buttons not working</b>	Plug into a powered electrical outlet.
	Try plugging the air purifier into a different outlet.
	Air purifier or the cord might be damaged.
	If these solutions don't work, DO NOT use the air purifier. Contact Customer Support. (See page 17)
<b>Air purifier makes an unusual noise</b>	Ensure that the filters is removed from their packaging. (See page 6)
	Ensure that the filter is placed correctly as described in this user manual.
	Replace the filters.(See page 10)
	Check the air purifier is on a hard, flat and dry surface.
	Air Purifier might be damaged or have a foreign object stuck inside. If these solutions do not work, DO NOT use the air purifier and DO NOT try to fix the problem. Contact Customer Support. (See page 17)
<b>Significantly reduced airflow</b>	Ensure that the filter is removed from its packaging. (See page 6)
	Press (  ) to increase the fan speed.
	Replace the filters. (See page 10)
<b>The (  ) indicator light is still on after changing the filters</b>	Check there is at least 40 cm of free space around the air purifier on each side. (See page 8)
	Tap and hold the (  ) for 3-5 seconds. The (  ) indicator light should turn OFF to indicate that the air purifier has been reset. (See page 12)
<b>The (  ) indicator light hasn't turned on in 6 months</b>	The (  ) indicator light might not turned on if you have not used your air purifier often in the past 6 months.
	You may need to change the filters more often or less often, depending on how much you use your air purifier and on how much pollution is in the air. (See page 10)
<b>There is a strange smell when the air purifier is ON</b>	Check if the filters need to be replaced. (See page 10)
	Ensure that the area is not humid or there aren't any essential oils or perfumes in the area. Air purifier might be damaged. Contact Customer Support. (See page 17)
<b>The air purification quality is low</b>	Press (  ) to increase the fan speed.
	The air purifier is effective in area up to 15 m <sup>2</sup> .
	Remove any debris blocking the airflow (inlet and outlet) of the air purifier.
	Ensure that the doors and windows are closed. (See page 8)
<b>The air does not flow evenly from the air purifier</b>	Check if the filters need to be replaced. (See page 10)
	Due to the design of this air purifier, this is normal and will not affect the efficiency of air purifier.

If your problem isn't listed in the above table, please contact customer support at [support@arovec.com.au](mailto:support@arovec.com.au) for assistance.

## WARRANTY AND DISCLAIMER FOR PRODUCTS

Arovec air purifiers are designed and manufactured to the highest quality standards. Your air purifier is covered for parts and labour (excluding filters) for 2 years, which includes 1 year standard warranty and 1- additional year upon registration (free of charge within 14 days) from the date of purchasing.

<b>Product name</b>	H13 True HEPA Air Purifier
<b>Model</b>	AV-P152 / AV-P152B
<b>Standard warranty period</b>	1 Year
<b>Additional warranty</b>	Extend your warranty for one additional year; Simply register on to <a href="http://arovec.com.au/warranty">arovec.com.au/warranty</a> within the first 14 days of your purchase.
<b>Record your order details here. This will help if you have any warranty questions in the future.</b>	
<b>Date of original purchase</b>	
<b>Order number</b>	

This warranty and disclaimer applies to all products purchased via the website [www.arovec.com.au](http://www.arovec.com.au) (hereinafter “Products”) or a third party seller authorised by Arovec.

**Note:** When the product is purchased from an authorised third party seller, for warranty claim, return and replacement of a defective product, the enquiry should be lodged via the related third party seller.

### (1) Warranty Against Defects

#### 1.1 For Brand-new Products:

We provide a 12-month standard warranty against defects with the Products, from the date of purchase.

We provide an optional additional free 12-month extended warranty against defects with the Products (resulting in a 24-month warranty against defects with the Products, from the date of purchase).

In order to claim the additional 12-month extended warranty, you must register your Product (free of charge) online at [www.arovec.com.au](http://www.arovec.com.au), within 14 days of the date of purchase. While registration, make sure that the related data entry including the date of purchasing are accurate.



In the event of a defect with the Product, you may be entitled to have the Product replaced. In order to be entitled to a replacement Product, you must:

- immediately stop using the Product; and
- notify us of the defect during the warranty period.

In order to claim a replacement Product, you must contact us using the details at the CUSTOMER SUPPORT section, to notify us of the defect, providing your proof of purchase and warranty registration confirmation as well as your contact details.

You may either:

- return the product for our further investigation; or
- send us a video of the defective Product, which demonstrates to our reasonable satisfaction that the Product is defective and undertake to safely dispose the defective Product. For safety reasons you must not continue to use the defective Product.

Upon receipt of the defective Product, or a video of the defective Product, we will inspect it. If the defect is the result of a manufacturer fault, we will determine if the fault requires a replacement or repair and either send you a replacement Product or effect a repair.

This warranty against defects is in addition to any other rights and remedies to which you may be entitled under Australian law.

To Clarify:

#### **What is covered by the warranty:**

- The repair or replacement of your Arovec product (at Arovec's discretion) if the product is found to be defective due to faulty manufacture. Arovec reserves the right to determine if the fault requires a replacement or repair.
- Packaging and instructions of a faulty product may also be replaced if damaged.
- This warranty is valid for using your personal use of your device within Australia only.

#### **What is not covered by the warranty:**

- Using the products for commercial purposes, or anything other than normal domestic personal use.
- Use of the product outside Australia.
- Accidental damage or faults caused by negligence, misuse, vandalism or neglect.
- Damage or faults caused by not following the instructions in the user manual.
- Unsupervised use by children under the age of 18.
- Repairs or alterations carried out by parties other than Arovec or an authorised agent.
- Any other conditions not listed above, are not covered by Arovec warranty.

## 1.2 For Renew Products:

A renew Product, which is purchased from a seller that is authorised by Arovec, is only covered under six months warranty and is not eligible for the free warranty extension.

## 1.3 For Replacements:

Replacement of a brand-new Product is only covered by the one-year standard warranty from the date of replacement arrangement and is not eligible for the one-additional year free warranty extension.

Replacement of a renew Product that is purchased from a seller and is authorised by Arovec is only covered by six months warranty from the date of replacement arrangement and is not eligible for the free warranty extension.

## (2) Australian Consumer Law

Our goods come with guarantees that cannot be excluded under the Australian Consumer Law. You are entitled to a replacement or refund for a major failure and compensation for any other reasonably foreseeable loss or damage. You are also entitled to have the goods repaired or replaced if the goods fail to be of acceptable quality and the failure does not amount to a major failure.

## (3) Disclaimer

You are solely responsible for evaluating the Product and determining whether it is fit for your purpose.

You acknowledge and agree that Product is not safe for use by children.

You acknowledge and agree that working with the Product is dangerous and carries the risk of electric shock, burns, lacerations, other injuries and death.

You acknowledge that you use the Product at your own risk and that you are responsible at all times for evaluating whether or not it is safe to use the Product.

## (4) Limitation of Liability

In addition to the requirements set out in clause 1 of this warranty and disclaimer document, the warranty provided under that clause will not apply:

- if a defect with the Product results in any way from some act or omission by you in relation to the appropriate care, maintenance and/or use of the Product; or
- if a defect with the Product results from ordinary wear and tear; or
- if you fail to follow our or the manufacturer's instructions for care, maintenance and/or use of the Product; or
- if you are unable to provide proof of purchase.

Except as otherwise provided by law, we accept no liability for any loss, damage or injury which may arise in any way from the use of the Product by you or by any other person.

Except as otherwise provided in this warranty and disclaimer, to the maximum extent permitted by law, we exclude all conditions and warranties implied by custom, law or statute, and we expressly disclaim all warranties of any kind including but not limited to implied warranties that the Product is fit for a particular purpose.

You hereby agree that we are not liable for any direct, indirect, consequential or incidental loss or damage which may result from your use of the Product.

Except as otherwise provided by law or as otherwise set out in this warranty and disclaimer, our liability to you shall be limited to the cost of replacement of the Product, together with your reasonable costs of postage and/or delivery in connection with your returning of the Product.

## **(5) Indemnity**

You agree to defend, indemnify and hold us and our officers, directors, employees, contractors, members, agents and licensees harmless from and against any and all claims, charges, actions, liabilities, investigations, demands and similar including but not limited to any costs, losses, damages whether direct, indirect, consequential or special and all legal fees resulting from your use of the Product, including but not limited to any third party claims.

## CUSTOMER SUPPORT - AUSTRALIA

Feel free to contact our helpful customer support team with any questions or inquiries regarding your product.

Your satisfaction is our priority.

Ausbrilliant Brands

PO Box2, Ermington NSW 1700, Australia

[www.avec.com.au](http://www.avec.com.au)

[support@avec.com.au](mailto:support@avec.com.au)

Please provide your order number when you contact customer support.

Alternatively, you may contact us using the contact us form on the website.

# NOTES

---

---

---

---

---

---

---

---

---

---

---

---

---

---







[www.arovec.com.au](http://www.arovec.com.au)