

Troubleshooting

Problem	Check the following points
Power does not come on	<ul style="list-style-type: none"> ● Check the battery.
The speaker won't pair	<ul style="list-style-type: none"> ● Move the speaker and your device close together. ● Pairing mode is disabled automatically after about 45 seconds. Turn the speaker off, then long press the On/Off/Pairing button until a second tone is emitted to enter pairing mode. ● Forget the "Planetarium Spkr" device in your device list. Scan for new bluetooth device. Then try pairing again.
The sound is too quiet or too loud	<ul style="list-style-type: none"> ● Adjust the volume on your device. It should be about 50%. ● Adjust the speaker volume.
The speaker is powered off automatically.	<ul style="list-style-type: none"> ● The battery is exhausted. Replace the battery or connect the AC adapter (not included)
No sound output.	<ul style="list-style-type: none"> ● Check if the volume level of the speaker is set to the minimum. ● Check if the volume level of your Bluetooth device connected to the system is set to minimum or set to mute. ● Check if your audio cable is connected to the Audio In jack of the speaker. Unplug the cable.
I hear cracking noises	<ul style="list-style-type: none"> ● For best audio quality, keep the speaker close to your device.
No sound output via Bluetooth or Bluetooth connection cannot be restored automatically.	<ul style="list-style-type: none"> ● The speaker may be powered off and powered on when playing back a track over Bluetooth connection. You need to make the connection again.
Speaker does not power off with the planetarium	<ul style="list-style-type: none"> ● The speaker and planetarium functions are independent and operate separately. Power on/off the speaker using the ON/OFF/Pairing button.

Using AC/DC adapter

This unit can be powered by an AC/DC adapter (not included). Connect an AC/DC adapter (5V 1000mA Output, 3.5mm Center Positive Plug —  —) into the Planetarium's 5V DC IN connector (26) and plug it into an AC wall outlet.

Battery Installation

Uses 3 AA (LR6) batteries (not included)

1. Twist and open the battery compartment door at the bottom.
2. Remove the battery cover with a screwdriver.
3. Insert three AA (LR6) batteries into the unit with polarity as indicated on the battery compartment.
4. Replace the battery cover and battery door.
5. Replace a new battery when the light becomes dim.
6. Insert new batteries according to the polarity marks.



IMPORTANT: Keep these instructions. DO NOT DISCARD.

Only adults should install and replace batteries. Alkaline batteries are recommended. Do not use rechargeable batteries. Non-rechargeable batteries are not to be recharged. If the device has not been used for a long time, remove the batteries. Rechargeable batteries are to be removed from the toy before being charged. Rechargeable batteries are only to be charged under adult supervision. Do not mix old and new batteries. Do not mix alkaline, standard (carbon zinc) or rechargeable (nickel cadmium) batteries. Exhausted batteries are to be removed from the toy. The supply terminals are not to be short-circuited. Only batteries of the same or equivalent type as recommended are to be used. Batteries are to be inserted with the correct polarity. Do not dispose of batteries in fire, batteries may explode or leak. Batteries may explode or leak if misused.

WARNING

Choking hazard. Never try to dismantle the product yourself, or push objects of any kind into the product, as this may cause short circuits which could result in a fire or electric shock. Do not expose this product to rain or moisture.

FCC Information

This equipment complies with FCC radiation exposure limits set forth for an uncontrolled environment. This equipment should be installed and operated with minimum distance 20cm between the radiator & your body.

This device complies with Part 15 of the Federal Communications Commission (FCC) Rules. Operation is subject to the following two conditions:

- This device may not cause harmful interference.
- This device must accept any interference received, including interference that may cause undesired operation.

CAUTION:

Changes or modifications to this unit not expressly approved by the party responsible for compliance could void the user's authority to operate this equipment.

This equipment has been tested and found to comply with the limits for a Class B digital device, pursuant to Part 15 of the FCC Rules. These limits are designed to provide reasonable protection against harmful interference in a residential installation. This equipment generates, uses and can radiate radio frequency energy and, if not installed and used in accordance with the manufacturer's instructions, may cause interference harmful to radio communications.

There is no guarantee, however, that interference will not occur in a particular installation. If this equipment does cause harmful interference to radio or television reception, which can be determined by turning the equipment off and on, the user is encouraged to try to correct the interference by one or more of the following measures:

- Reorient or relocate the receiving antenna.
- Increase the separation between the equipment and receiver.
- Connect the equipment to an outlet on a circuit different from that to which the receiver is connected.
- Consult the dealer or an experienced radio or TV technician for help.

Model No.: 8007

Input: 3 X 1.5V LR6 / DC 5V 1000mA —  —

Made in China

© 2014 Eastcolight (Hong Kong) Limited. All rights reserved.



User Instructions

Planetarium with Wireless Bluetooth® Speaker

COMPONENTS

- 1 ON/STOP/OFF switch
- 2 Sleep Timer Button
- 3 30 Minute Sleep Indicator
- 4 60 Minute Sleep Indicator
- 5 Rotate Right Button
- 6 Rotate Right Indicator
- 7 Slide Tray Eject Button
- 8 Rotate Left Button
- 9 Rotate Left Indicator
- 10 Shooting Star Button
- 11 Shooting Star Indicator
- 12 Date Dial
- 13 Time Scale
- 14 Focus Dial
- 15 Stand
- 16 Star Disc (2 pieces)
- 17 Speaker ON/OFF/Pairing Button
- 18 Vol + /Next Song Button
- 19 Quickpress = Next Song
- 20 Press & Hold = Volume Up
- 21 Vol - /Previous Song Button
- 22 Quickpress = Previous Song
- 23 Press & Hold = Volume Down
- 24 Play/Pause Button
- 25 Star Disc tray
- 26 Speakers
- 27 Shooting star projection lens
- 28 Main projection lens
- 29 Audio IN Connector
- 30 5V DC IN Connector
- 31 Speaker Status LED
- 32 Audio cable

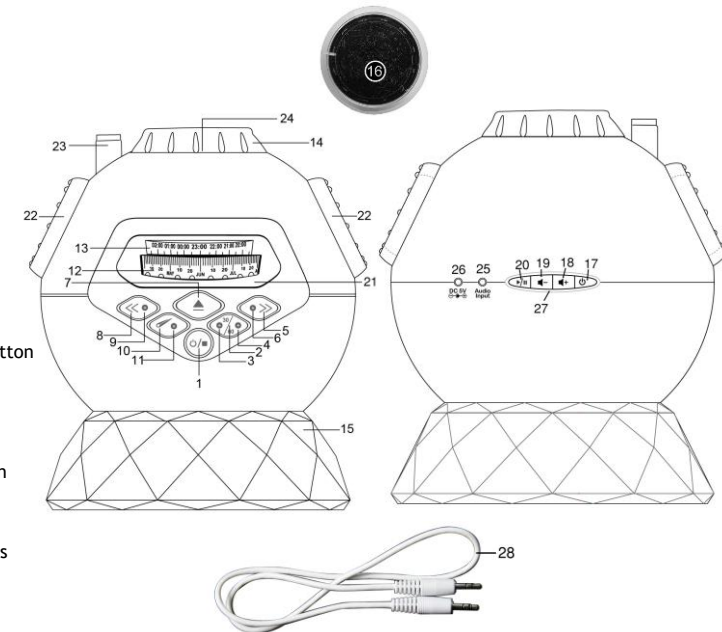

Setting up the Planetarium

1. Open the battery cover at the bottom of the unit and insert 3 pieces of AA size batteries. Please refer to the "Battery Installation Section" below. Replace battery cover firmly.

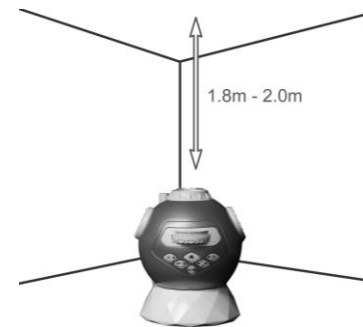

2. Place the unit over the stand (15) on a flat and stable platform (e.g. a table), the optimum project distance is about 1.8m to 2m.

3. Press the Slide Tray Eject Button (7) to open the tray and install the star disc (16). Note the keys on the disc have to match the ridges on the tray.

4. While the slide tray is still opened, set the time and date of the night sky you want to view by aligning the desired date on Date Dial with the desired hour on the Time Scale.

Time Scale (fixed): Time from 20:00 (8 p.m.) to 02:00 (2 a.m.) is shown. Align the Date Dial with it to project stars at a particular time. (Each subdivision equals 30 minutes.)

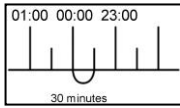

Date Dial (Adjustable): The Date Dial has 365 days. Adjust the dial to project stars you want to see on a particular date. (Each subdivision equals to 2 days. The long mark corresponds to the last day of the previous month.)

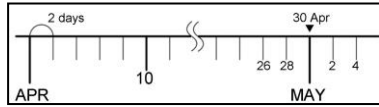

Example 1: If you want to see the star pattern at mid-night (00:00) on 7th July, align 00:00 on the time scale with 7th July. Position of the date 7th is between 6th and 8th.

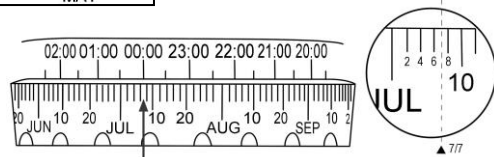

Example 2: If you want to see the star pattern at 22:30 (10:30 p.m.) on 30th December, align 22:30 on the time scale with 30th December. As shown in the figure, the small marking represents 3 days. Therefore the day 30th would be at 2/3 of the marking. (The same setting applies to January, March, May, July, August and October.) Note that 28th and 29th of February are at the same mark.

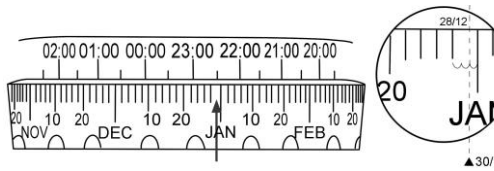

5. Close the tray. Note that you are looking to the north when you face the star projector from the front. Please do not turn the Date Dial when the tray is closed. You need to open the tray again if you want to set the date, or you can use the Rotate Left (8) or Rotate Right button (5) while the unit is turned on.

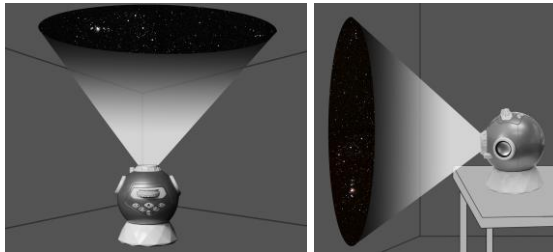

6. Press the ON/STOP/OFF switch (1) once to turn on the Projector Light. Dim or turn off the light in the room for best visual experience. Note that the unit cannot be turned on when the tray is opened.

7. You can freely adjust the projection angle of the projection head over the stand (15) to suit viewing on the ceiling or sidewall.

8. Adjust the focus dial (14) until the projected star field is sharp. The optimum project distance is 1.8m to 2m, image will become blur if the distance is too near or too far.



Using the Star Motion Function

1. Press the Rotate Left Button (8) to rotate the night sky anticlockwise, which is the motion of the stars in the northern hemisphere. Press the button again to increase the rotation speed. A total of five speed is available. Each press will select the next higher speed. The Rotate Left Indicator (9) will blink according to the speed. Press the "ON/STOP/OFF" button to stop.

2. Similarly, press the Rotate Right Button (5) to rotate the stars clockwise, which is the motion of the stars in the southern hemisphere. A total of five speed is also selectable.

Using the Shooting Star Function

When the night sky is in the rotating state, press the Shooting Star Button (10) to enable the shooting star function. A shooting star will appear in the night sky at regular time interval. It will appear more frequently if the rotating speed is set higher. Press the same button again to disable shooting star.

Using the Timer Function

Press the Sleep timer button (2) to enable 30 or 60 minute sleep timer, the corresponding LED indicator will show the current selected timer. To disable sleep timer, press the timer button until both timer indicator light (3,4) are off. However, the projector will still turn off automatically in 2 hours to save battery.

Powering OFF

Press and hold the ON/STOP/OFF (1) button to turn off the projector.

Set up the Bluetooth speaker

Note: Ensure the audio cable is removed from the "Audio Input" jack (25) of the speaker in order to use the Bluetooth function.

Pairing the speaker and a device

1. Make sure the speaker is turn off and keep it within 30 feet of the device it is paired to. Now press and hold the On/Off/Pairing button until a second tone is emitted. The status LED (27) will flash in RED and BLUE alternatively, indicating it is in pairing mode.
2. On your device (smartphone or tablet), locate your Bluetooth setting and turn on Bluetooth.
3. In Bluetooth Settings, scan for devices if necessary, then select "Planetarium Spkr" from your device's list. The status LED will change to blinking twice (in BLUE) every 5 seconds if the connection is successful. Your device and speaker are paired and your speaker is ready to use.

Pairing another device

Turn off the speaker by pressing and holding the On/Off/Pairing button until a second tone is emitted. The status LED (27) will turn off. Repeat step 1 - 3 above to connect to a new device.

Reconnecting to a paired device

1. Turn on the speaker by pressing and holding the On/Off/Pairing button until a first tone is emitted. The status LED (27) will flash BLUE quickly indicating it is in device searching mode.
2. Turn on Bluetooth function of your device within 45 seconds. Connection is established automatically and a double tone will sound. However, if Bluetooth is turned on after this period or automatic connection is unsuccessful, you can still connect manually by selecting "Planetarium Spkr" from your device's list.

Play Music

Select the desired music and press "Play" button on your paired device. The speaker will automatically start playing back the music.

1. On the speaker, press and hold the "▲+" or "▼-" button (18,19) to increase or decrease volume.
2. Quickpress the "▲+" or "▼-" button to skip forward or backward a track.
3. Press "▶ ||" button (20) to pause or resume play.

Status LED

Pairing mode	RED and BLUE LED blinks alternatively every second
Searching connection	BLUE LED blinks once every half second
Disconnected	BLUE LED blinks once every 5 seconds
Connected	BLUE LED blinks twice every 5 seconds
Playing music	RED and BLUE LED blinks every 5 seconds
Power on / Power off	RED and BLUE LED blinks 3 times

Connect with Audio Cable

Connect a music player's audio output or smartphone's earphone output to the Audio IN connector (25) at the back of the unit with a 3.5mm audio cable (included). The speaker automatically disconnects from Bluetooth. Press and hold the "▲+" or "▼-" buttons to adjust the volume.

Technical Specifications

Viewing Location:	N35°
Constellations:	61
Stars:	8000
Light Source:	High Brightness White LED
Star field orientation adjustment:	Date, Hour
Projection Area:	1.8 x 2.2m at 2.0m distance
Number of stars:	8000 (each star disc)
Auto Off Timer:	30, 60, 120 minute
Power:	5V DC / 3 x 1.5V AA/LR6
Speaker Power:	1.5W x 2
Bluetooth:	Version 5.0



If at any time in the future you should need to dispose of this product please note that waste electrical products should not be disposed of with household waste. Please recycle where facilities exist. Check with your Local Authority or retailer for recycling advice. (Waste Electrical and Electronic Equipment Directive)