		General tolerance SFS-EN 2768-m		Description with Roll-center / bump steer correction -kit			
		Welded structures EN-ISO 13920		Specification E30 / E36 / E46			
Drawn By	ML	Date	11/10/2021		Number <b>MRT-20003-W</b>	Rev <b>A</b>	
Approved By	NL	Date	18/10/2021				
Type		Finish		Material	Mass	Scale 1:1	Sheet 1 / 2 A3

#	PART NUMBER	DESCRIPTION	SPEC	QTY. per side
1	MRT-10003-1W	Control arm mounting stud		1
2	MRT-10003-2W	Tie rod mounting stud		1
3	MRT-10003-3.1W	Spindle nylon sleeve, 12mm, small taper	E30 / E36	1
4	MRT-10003-3.2W	Spindle nylon sleeve, 12mm, big taper	E46	1
5	MRT-10003-4W	Castle nut M12x1.5		1
6	MRT-10003-4	Castle nut, M14x1.5		1
7	MRT-10003-5.1	Spindle nylon sleeve, 14mm, small taper	E30 / E36 / E46	1
8	MRT-10003-5.2	Spindle nylon sleeve, 14mm, big taper	E46 M3	1
9	MRT-10006-1	Tie rod extension		1
10	MRT-10006-3	Bump steer shim, 5mm		2
11	XM14x1.5	rod end		1
12	DIN985 M14x1.5	nyloc nut		1
13	DIN985 M12x1.5	nyloc nut		1
14	DIN936 M14x1.5	half nut		2
15	74992DP 14	nordlock washer		1
16	74992DP 12	nordlock washer		1
17	DIN94 3.2x25	pin		1
18	DIN94 2x25	pin		1

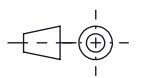
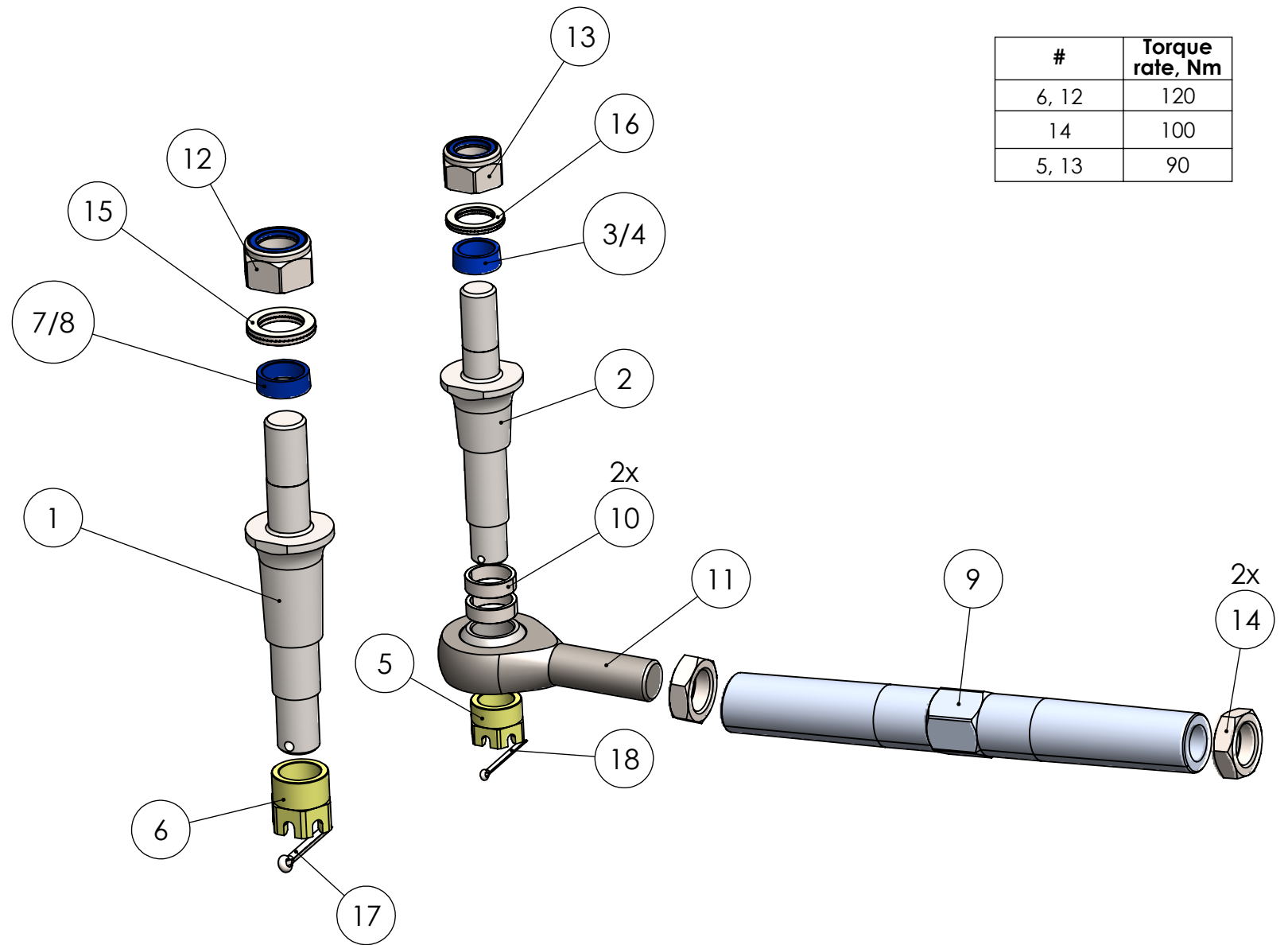

#	Torque rate, Nm
6, 12	120
14	100
5, 13	90

		General tolerance SFS-EN 2768-m		Description with Roll-center / bump steer correction -kit	
		Welded structures EN-ISO 13920		Specification E30 / E36 / E46	
Drawn By	Name	Date		Number MRT-20003-W	
Approved By	NL	18/10/2021		Rev A	
Type	Finish		Material	Mass	Scale 1:2 Sheet 2 / 2 A3