			General tolerance SFS-EN 2768-m Welded structures EN-ISO 13920		Description with Mounting stud -kit	
					Specification E30 / E36 / E46	
	Name	Date		Number MRT-10004-17		Rev A
Drawn By	ML	13/10/2021				
Approved By	NL	29/12/2021				
Type			Finish	Material	Mass	Scale 1:1 Sheet 1 / 2 A3

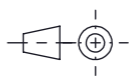

#	Torque rate, Nm
2, 5	120

#	PART NUMBER	DESCRIPTION	SPEC	QTY. per side
1	MRT-10004-17	Mounting stud		1
2	MRT-10003-4	Castle nut, M14x1.5		1
3	MRT-10003-5.1	Spindle nylon sleeve, 14mm, small taper	<i>E30 / E36 / E46</i>	1
4	MRT-10003-5.2	Spindle nylon sleeve, 14mm, big taper	<i>E46 M3</i>	1
5	DIN985 M14x1.5	nyloc nut		1
6	74992DP 14	nordlock washer		1
7	DIN94 3.2x25	pin		1

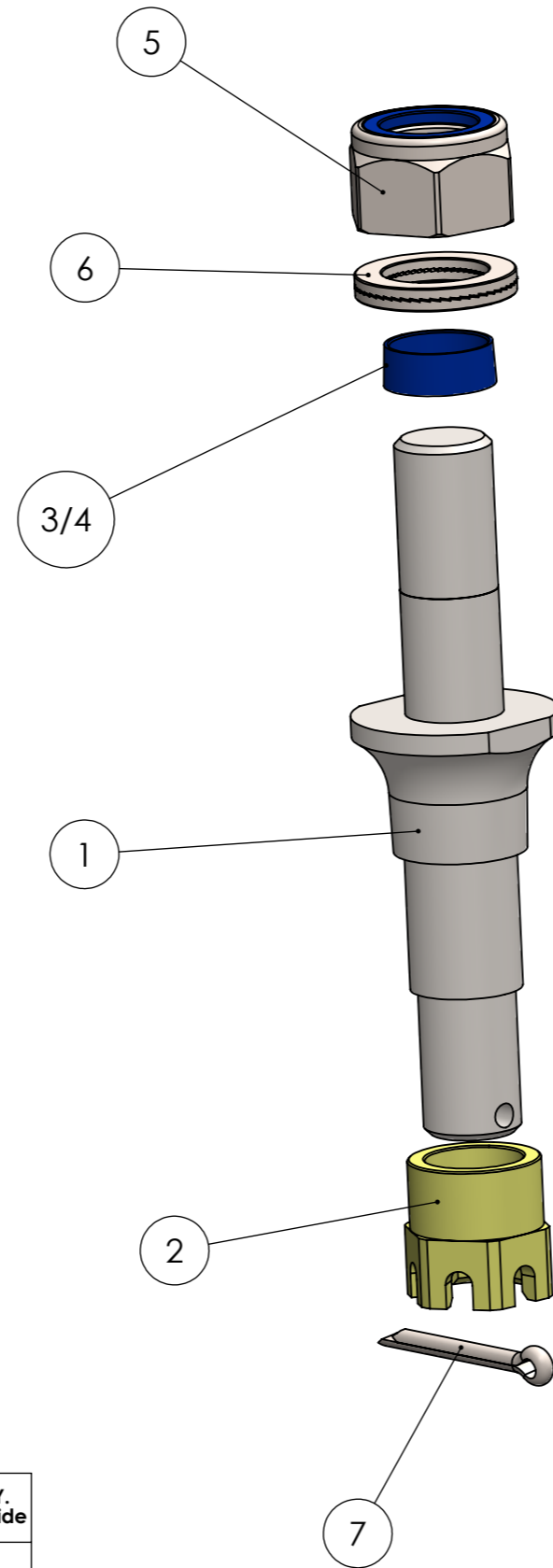

General tolerance
SFS-EN 2768-m
Welded structures
EN-ISO 13920

Description
with Mounting stud -kit

Specification
E30 / E36 / E46

	Name	Date
Drawn By	ML	13/10/2021
Approved By	NL	29/12/2021
Type		

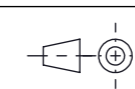

Number
MRT-10004-17

Rev
A

Material	Mass	Scale 1:1	Sheet 2 / 2 A3