

		General tolerance SFS-EN 2768-m		Description E30 5-lug adapter kit		
		Welded structures EN-ISO 13920		Specification Front		
Drawn By	Name ML	Date 14/09/2023		Number MRT-20019		Rev A
Approved By				Type	Material	Scale 1:1

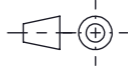
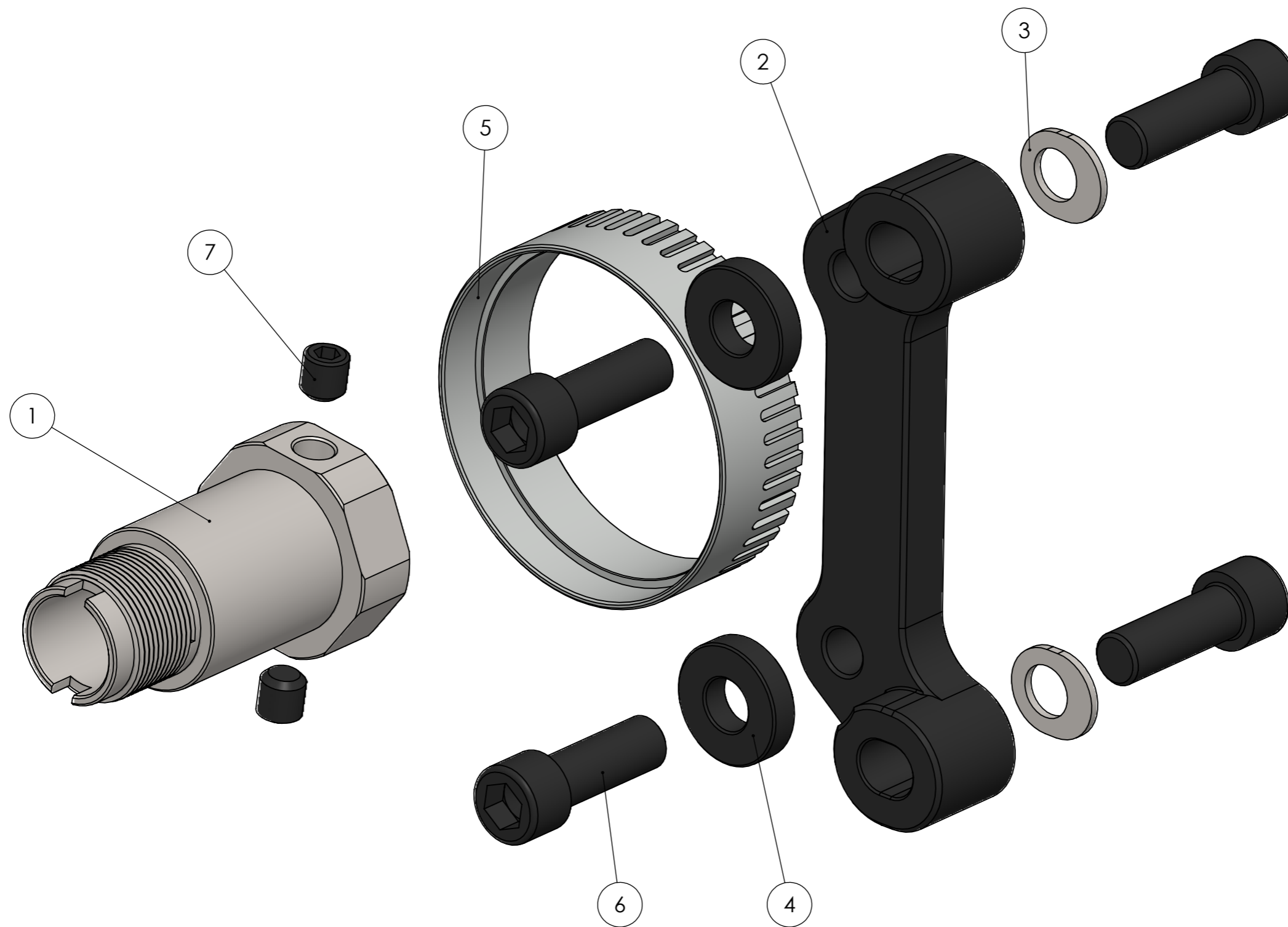
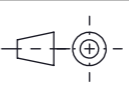

#	PART NUMBER	DESCRIPTION	SPEC	QTY. per side
1	MRT-10019-1	Wheel bearing adapter		1
2	MRT-10019-2	Brake caliper adapter, front		1
3	MRT-10019-3	Eccentric washer		2
4	MRT-10019-4	Spacer	///M brake calipers	2
5	MRT-10019-5	ABS sensor ring	E30	1
6	DIN912 M12x1.5x35	bolt		4
7	DIN913 M10x1x10	set screw		2

		General tolerance SFS-EN 2768-m		Description E30 5-lug adapter kit		
		Welded structures EN-ISO 13920		Specification Front		
Drawn By	Name ML	Date 14/09/2023		Number MRT-20019		Rev A
Approved By				Material	Scale 1:1	Sheet 2 / 2 A3
Type			Finish			