			General tolerance SFS-EN 2768-m Welded structures EN-ISO 13920		Description Solid aluminum mounts	
					Specification BMW M5X engine, ZF gearbox	
	Name	Date		Number <b>MRT-20013</b>		Rev <b>A</b>
Drawn By	ML	12/10/2021				
Approved By	NL	18/10/2021				
Type			Finish	Material	Mass	Scale 1:1 Sheet 1 / 2 A3

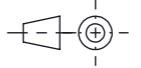

#	Torque rate, Nm
5	47
4, 6	25

#	PART NUMBER	DESCRIPTION	SPEC	QTY. per side
1	MRT-10013-1	Engine mount	BMW M5X	1
2	MRT-10013-2	Gearbox mount	BMW ZF	1
3	DIN939 M10x25	stud		2
4	DIN931 M8x70	bolt		1
5	DIN6926 M10	flange nyloc nut		2
6	DIN6926 M8	flange nyloc nut		1
7	DIN125 M10	washer		2
8	DIN125 M8	washer		2
9	DIN7 10x16	pin		1

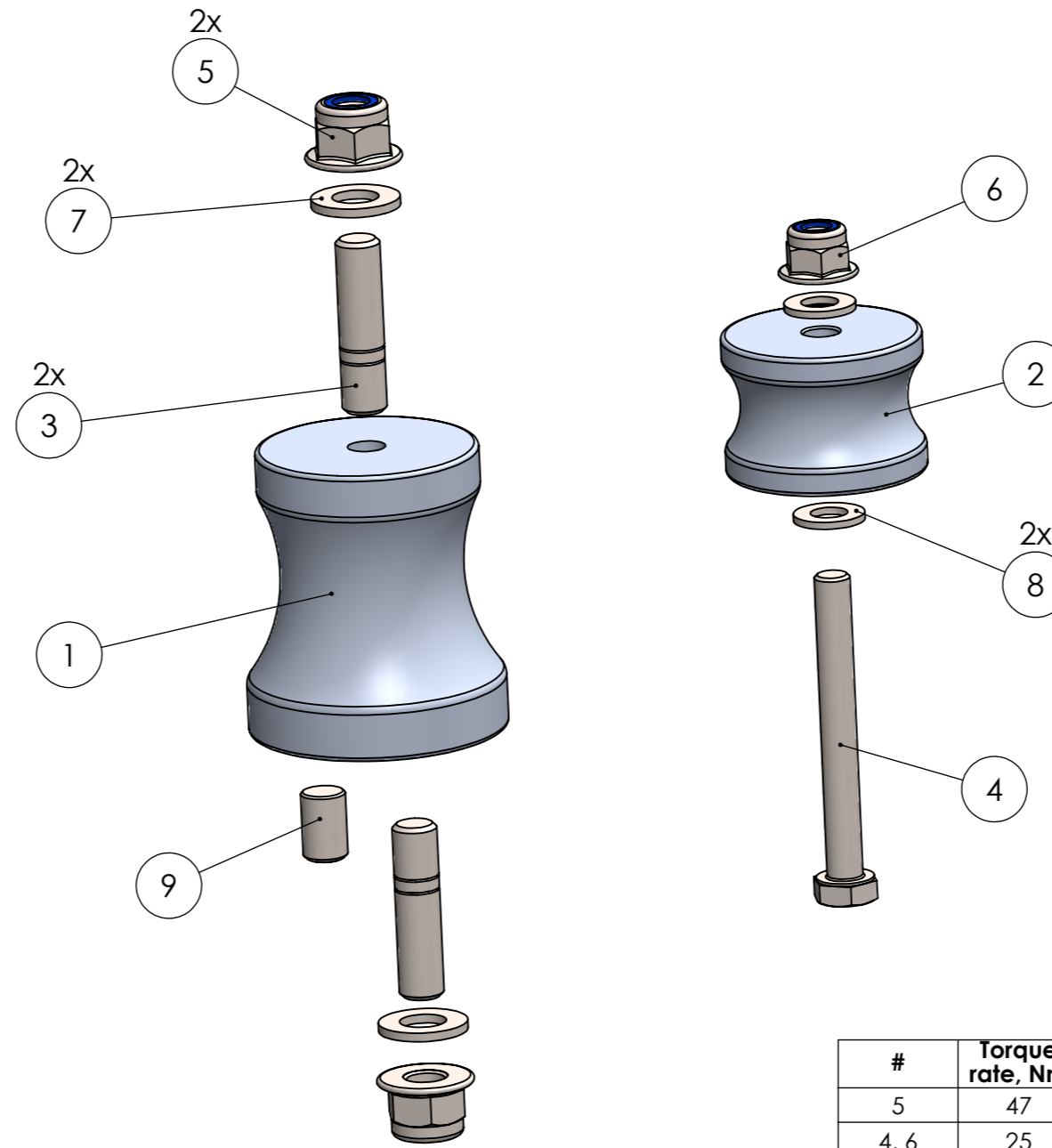

Drawn By	ML	Date	12/10/2021
Approved By	NL	Date	18/10/2021
Type			

General tolerance  
SFS-EN 2768-m  
Welded structures  
EN-ISO 13920

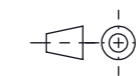

Finish

Description  
Solid aluminum mounts  
Specification  
BMW M5X engine, ZF gearbox

Number  
**MRT-20013**

Rev  
**A**

Material | Mass | Scale 1:1.5 | Sheet 2 / 2 A3