

		General tolerance SFS-EN 2768-m Welded structures EN-ISO 13920		Description E30 Gr.A DTM trailing arm double adjuster kit with spherical inner joints		
				Specification Horizontal mount		
Drawn By ML	Name ML	Date 01/03/2022		Number MRT-20007-4H		Rev
Approved By				Type	Material	Mass

#	Torque rate, Nm
14	45
9, 13	100
4	200

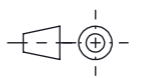
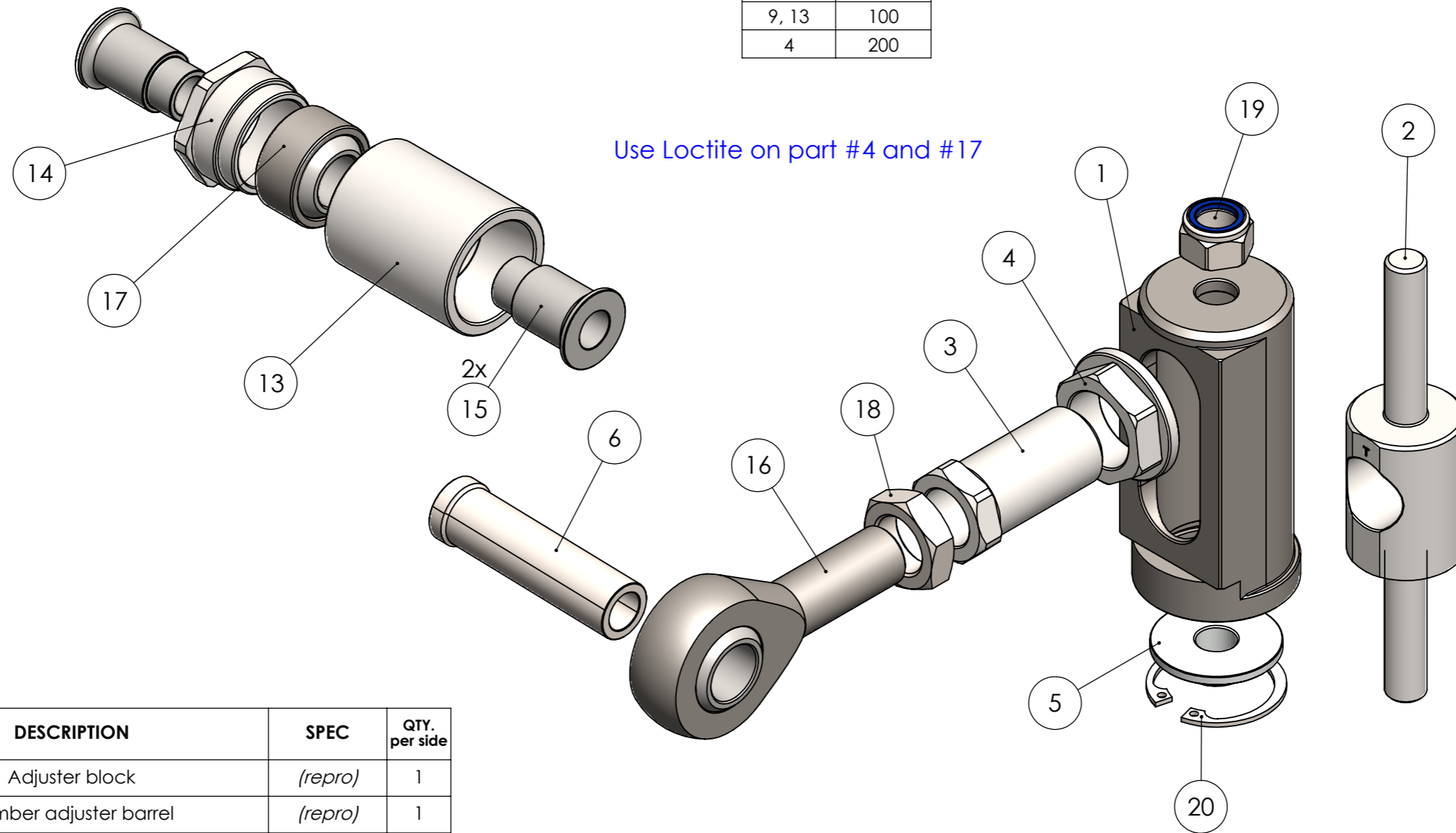

Use Loctite on part #4 and #17

#	PART NUMBER	DESCRIPTION	SPEC	QTY. per side
1	MRT-10007-11	Adjuster block	(repro)	1
2	MRT-10007-12	Camber adjuster barrel	(repro)	1
3	MRT-10007-13	Toe adjuster screw	(repro)	1
4	MRT-10007-14	Toe adjuster lock nut	(repro)	1
5	MRT-10007-15	Base plate	(repro)	1
6	MRT-10007-7	18mm sleeve		1
13	MRT-10007-17	Bearing cup	(repro)	1
14	MRT-10007-18	Bearing retainer	(repro)	1
15	MRT-10007-19	16mm rod end spacer 24mm	inner	2
16	XM18x1.5	rod end		1
17	GEBJ16C	spherical bearing		1
18	DIN936 M18x1.5	half nut		1
19	DIN985 M12x1.5	nyloc nut		1
20	DIN472 38x1.5	DIN472 34x1.5 circlip		1

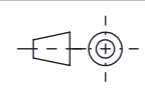
	General tolerance SFS-EN 2768-m Welded structures EN-ISO 13920	Description E30 Gr.A DTM trailing arm double adjuster kit with spherical inner joints		
		Specification Horizontal mount		
Drawn By ML	Name ML	Date 01/03/2022	Number MRT-20007-4H	
Approved By				Rev
Type	Finish	Material	Scale 1:1.5	Sheet 2 / 2 A3