

		General tolerance SFS-EN 2768-m		Description E30 Gr.A DTM bump steer adjustable tie rod kit		
		Welded structures EN-ISO 13920		Specification w/ Rodobal RM12MTE rod ends		
Drawn By	Name ML	Date 12/11/2022		Number MRT-20006-3/4R		Rev A
Approved By				Type	Material	Mass

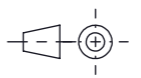
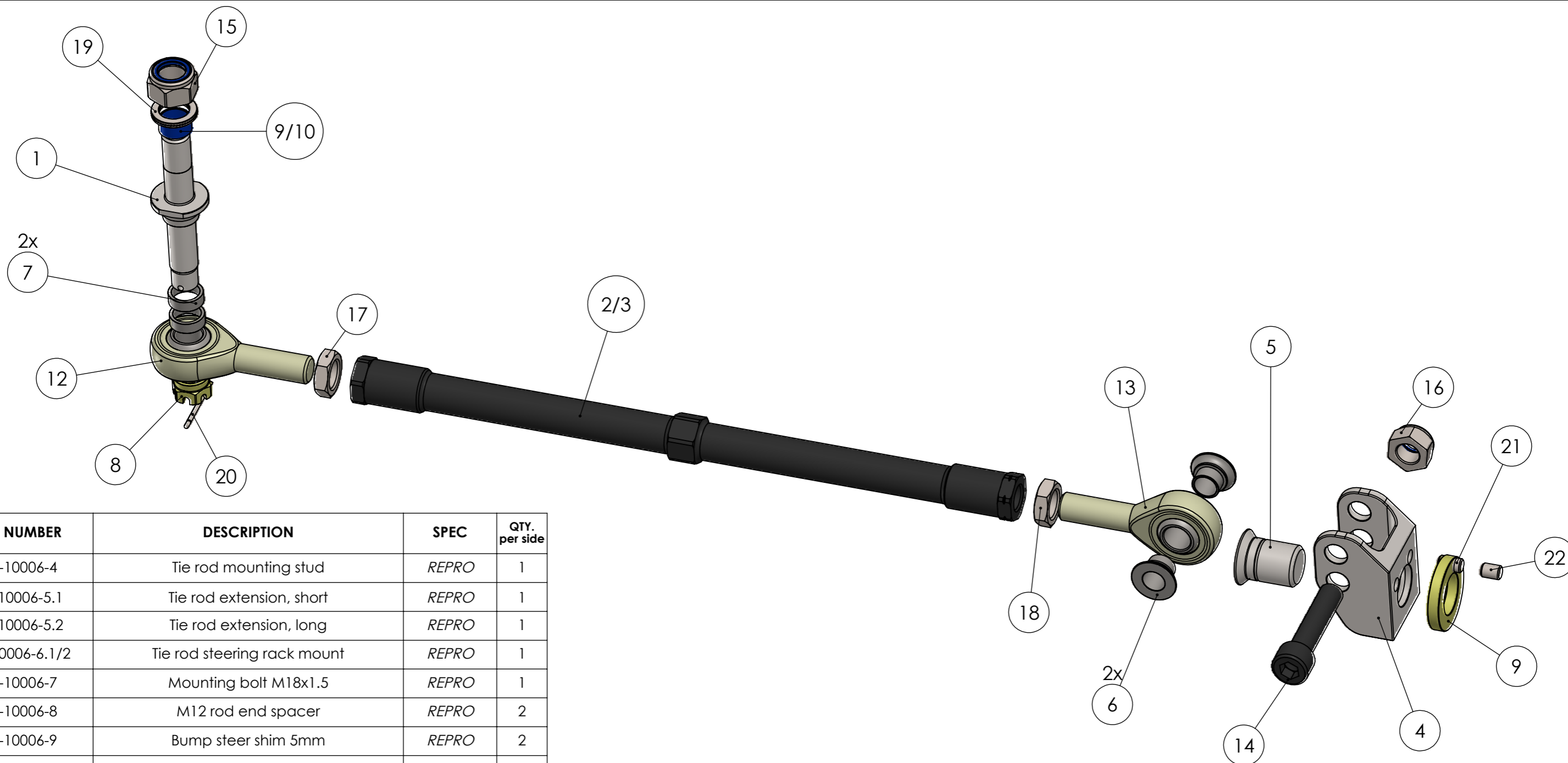
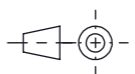

#	PART NUMBER	DESCRIPTION	SPEC	QTY. per side
1	MRT-10006-4	Tie rod mounting stud	REPRO	1
2	MRT-10006-5.1	Tie rod extension, short	REPRO	1
3	MRT-10006-5.2	Tie rod extension, long	REPRO	1
4	MRT-10006-6.1/2	Tie rod steering rack mount	REPRO	1
5	MRT-10006-7	Mounting bolt M18x1.5	REPRO	1
6	MRT-10006-8	M12 rod end spacer	REPRO	2
7	MRT-10006-9	Bump steer shim 5mm	REPRO	2
8	MRT-10006-10	Castle nut 7/16"-20	REPRO	1
9	MRT-10006-11	Steering rack spacer	REPRO	1
10	MRT-10003-3.1W	Spindle nylon sleeve, 12mm, small taper	E30 / E36	1
11	MRT-10003-3.2W	Spindle nylon sleeve, 12mm, big taper	E46	1
12	RM12MTEx1.5	rod end		1
13	RM12MTEx1.5 LH	rod end		1
14	DIN912 M10x45	bolt		1
15	DIN985 M12x1.5	nyloc nut		1
16	DIN985 M10	nyloc nut		1
17	DIN936 M12x1.5	half nut		1
18	DIN936 M12x1.5 LH	half nut		1
19	74992DP 12	nordlock washer		1
20	DIN94 2x25	pin		1
21	DIN7 6x10	pin		1
22	DIN7 6x8	pin		1

		General tolerance SFS-EN 2768-m Welded structures EN-ISO 13920		Description E30 Gr.A DTM bump steer adjustable tie rod kit	
				Specification w/ Rodobal RM12MTE rod ends	
Drawn By ML		Date 12/11/2022		Number MRT-20006-3/4R	
Approved By					
Type		Finish		Material	
				Mass	
				Scale 1:1.75 Sheet 2 / 2 A3	