		General tolerance SFS-EN 2768-m		Description Bump steer adjustable tie rod kit		
		Welded structures EN-ISO 13920		Specification BMW E30 / E36 / E46		
Drawn By	Name ML	Date 02/04/2023		Number MRT-20006-1		Rev B
Approved By				Type	Material	Mass

#	Torque rate, Nm
7	100
4, 8	45

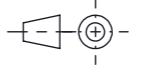
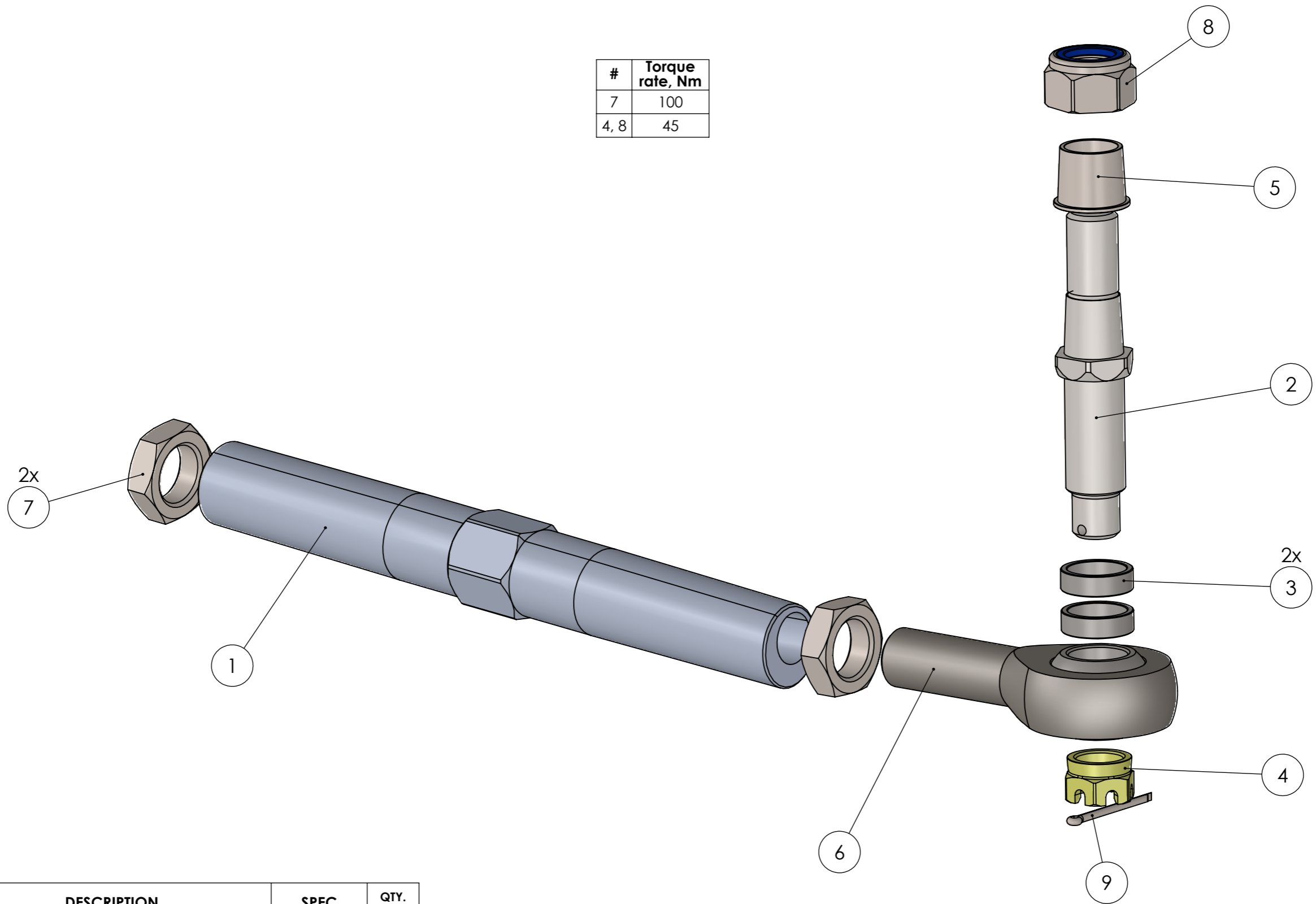

#	PART NUMBER	DESCRIPTION	SPEC	QTY. per side
1	MRT-10006-1	Tie rod extension		1
2	MRT-10006-2B	Tie rod mounting stud		1
3	MRT-10006-3	Bump steer shim, 5mm		2
4	MRT-10006-10	Castle nut 7/16"-20		1
5	MRT-10003-2	Tie rod taper adapter	E46 spindles	1
6	XM14x1.5	rod end		1
7	DIN936 M14x1.5	half nut		2
8	DIN985 M12x1.5	nyloc nut		1
9	DIN94 2x25	pin		1

		General tolerance SFS-EN 2768-m		Description Bump steer adjustable tie rod kit	
		Welded structures EN-ISO 13920		Specification BMW E30 / E36 / E46	
Drawn By	Name ML	Date 02/04/2023		Number MRT-20006-1	
Approved By				Rev B	
Type	Finish		Material	Mass	Scale 1:1 Sheet 2 / 2 A3

This document must not be copied without our written permission, and the contents thereof must not be imparted to a third party nor be used for any unauthorized purpose. Contravention will be prosecuted.