

		General tolerance SFS-EN 2768-m		Description Roll-center / bump steer / angle -kit		
		Welded structures EN-ISO 13920		Specification BMW E30 / E36 / E46		
Drawn By	ML	Date	15/09/2021		Number MRT-20003	Rev A
Approved By	NL	Date	18/10/2021		Type	Material
		Finish		Mass	Sheet 1 / 2	A3

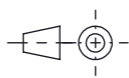
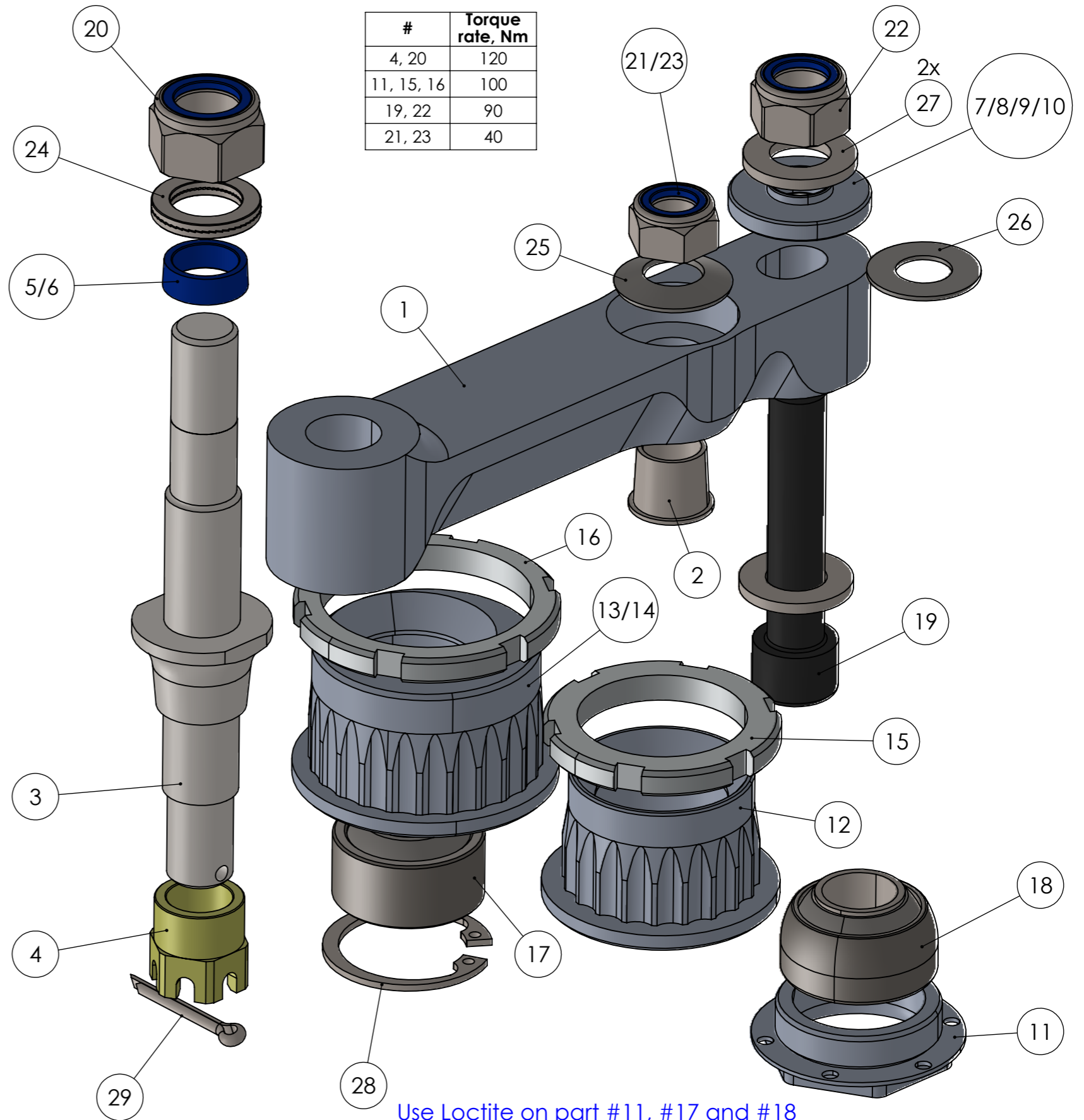
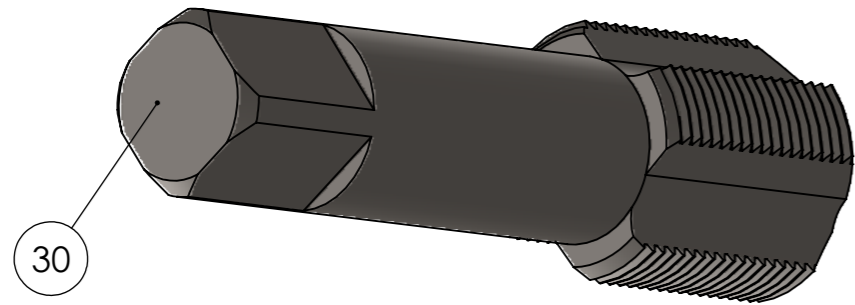

Use Loctite on part #11, #17 and #18

#	PART NUMBER	DESCRIPTION	SPEC	QTY. per side
1	MRT-10003-1	Steering adapter		1
2	MRT-10003-2	Tie rod taper adapter	E30 / E36	1
3	MRT-10003-3	Control arm mounting stud		1
4	MRT-10003-4	Castle nut, M14x1.5		1
5	MRT-10003-5.1	Spindle nylon sleeve, 14mm, small taper	E30 / E36 / E46	1
6	MRT-10003-5.2	Spindle nylon sleeve, 14mm, big taper	E46 M3	1
7	MRT-10003-6.1	Spindle spacer, 4.5mm, small taper	E36 M3 3.0	1
8	MRT-10003-6.2	Spindle spacer, 7.5mm, small taper	E36 non-M	1
9	MRT-10003-6.3	Spindle spacer, 6mm, big taper	E46 non-M	1
10	MRT-10003-6.4	Spindle spacer, 7mm, big taper	E46 M3	1
11	MRT-10003-7	Bearing retainer, M35x1.5	E46 M3	1
12	MRT-10003-8.1	Bearing cup, 41mm	E30 / E36 M3 LCA	1
13	MRT-10003-8.2	Bearing cup, 48.5mm	E36 non-M / E46 aftermarket LCA	1
14	MRT-10003-8.3	Bearing cup, 50mm	E46 OEM LCA	1
15	MRT-10003-9.1	Bearing cup nut, M39x1.5	41mm bearing cup	1
16	MRT-10003-9.2	Bearing cup nut, M48x1.5	48.5 / 50mm bearing cup	1
17	GEBJ16C	spherical bearing		1
18	GE18MRT	spherical bearing 33mm	E46 M3	1
19	DIN912 M12x60	bolt		1
20	DIN985 M14x1.5	nyloc nut		1
21	DIN985 M12x1.5	nyloc nut	E46	1
22	DIN985 M12	nyloc nut		1
23	DIN985 M10x1	nyloc nut	E30 / E36	1
24	73992DP 14	nordlock washer		1
25	DIN2093 12.2x25x1.2	spring washer		1
26	DIN988 12x24x1	shim washer	E36 M3 3.2	1
27	DIN125 M12	washer		2
28	DIN472 34x1.5	circlip		1
29	DIN94 3.2x25	pin		1
30	DIN2181 M35x1.5	thread tap	E46 M3	1

		Description		Roll-center / bump steer / angle -kit	
		Specification		BMW E30 / E36 / E46	
General tolerance SFS-EN 2768-m Welded structures EN-ISO 13920		Number		MRT-20003	
Drawn By: ML Approved By: NL Type:		Date: 15/09/2021 Date: 18/10/2021		Rev: A	
Finish		Material		Scale 1:1	
		Mass		Sheet 2 / 2 A3	