

			General tolerance SFS-EN 2768-m		Description Cam sensor cover	
			Welded structures EN-ISO 13920		Specification BMW M20 / M30 / S38	
Drawn By	Name ML	Date 22/09/2021		Number MRT-20001		Rev A
Approved By	NL	18/10/2021		Type	Material	Mass

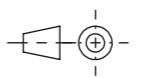
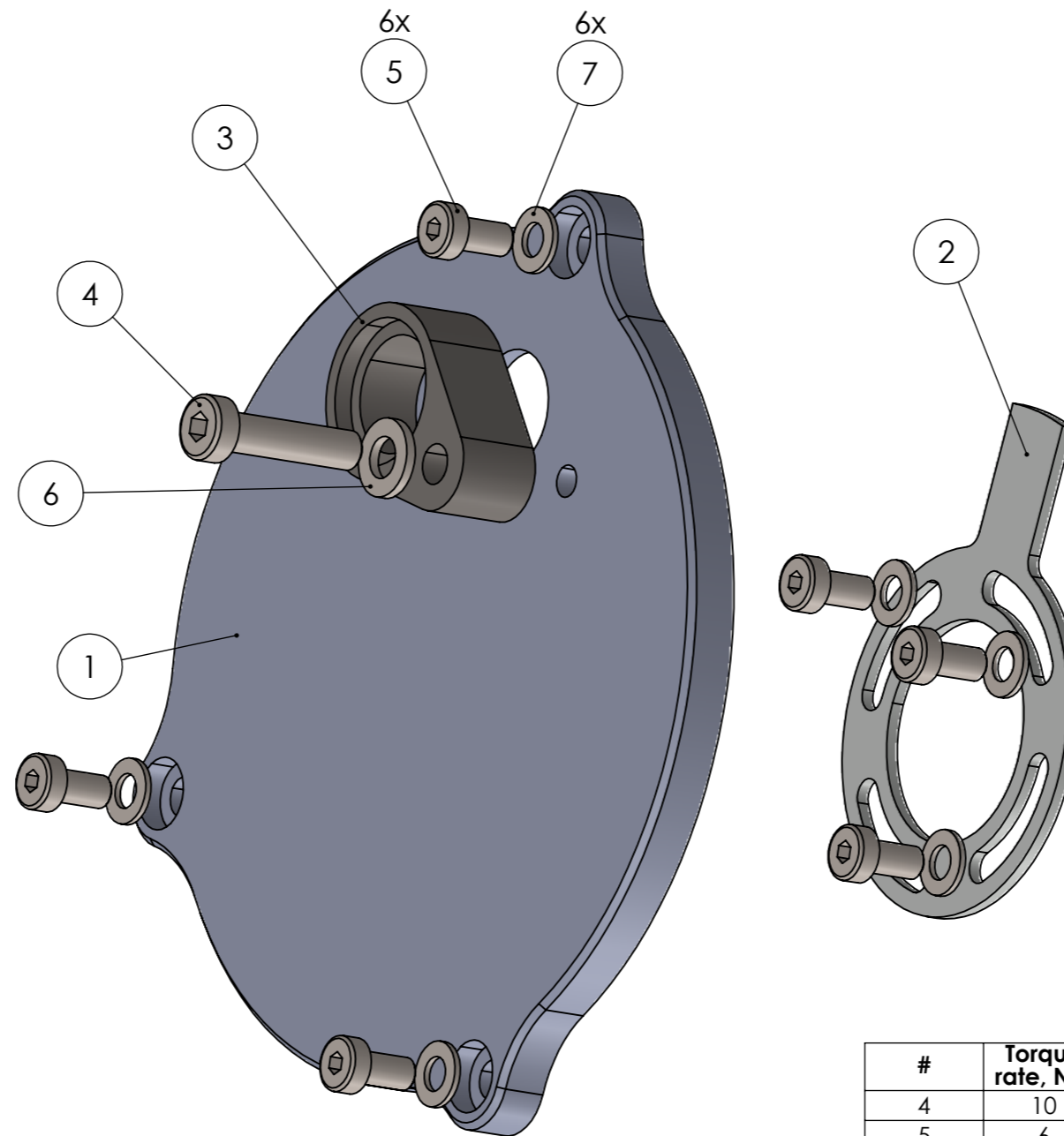

#	Torque rate, Nm
4	10
5	6

Assemble trigger lever bolts with Loctite

#	PART NUMBER	DESCRIPTION	SPEC	QTY.
1	MRT-10001-1	Aluminum cover		1
2	MRT-10001-2	Trigger lever		1
3	MRT-10001-3	Sensor adapter		1
4	DIN7984 M6x25	screw		1
5	DIN7984 M5x10	screw		6
6	DIN125 M6	washer		1
7	DIN125 M5	washer		6

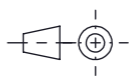
	General tolerance SFS-EN 2768-m Welded structures EN-ISO 13920		Description Cam sensor cover	
	Name ML Date 22/09/2021		Specification BMW M20 / M30 / S38	
Drawn By Approved By Type		Date 18/10/2021		Number MRT-20001
				Rev A
		Finish		Material Mass Scale 1:1 Sheet 2 / 2 A3