

		General tolerance SFS-EN 2768-m		Description																			
		Welded structures EN-ISO 13920		Front suspension geometry																			
<table border="1"> <tr> <td>Drawn By</td> <td>ML</td> <td>Date</td> <td>03/07/2023</td> </tr> <tr> <td>Approved By</td> <td></td> <td></td> <td></td> </tr> <tr> <td>Type</td> <td></td> <td>Finish</td> <td></td> </tr> </table>		Drawn By	ML	Date	03/07/2023	Approved By				Type		Finish		<table border="1"> <tr> <td>Specification</td> <td>E30 non-M with E36 non-M spindle and eccentric FCAB</td> </tr> <tr> <td>Number</td> <td></td> </tr> <tr> <td>Material</td> <td></td> </tr> </table>		Specification	E30 non-M with E36 non-M spindle and eccentric FCAB	Number		Material		Rev	
Drawn By	ML	Date	03/07/2023																				
Approved By																							
Type		Finish																					
Specification	E30 non-M with E36 non-M spindle and eccentric FCAB																						
Number																							
Material																							
				Scale 1:5	Sheet 1 / 2 A3																		

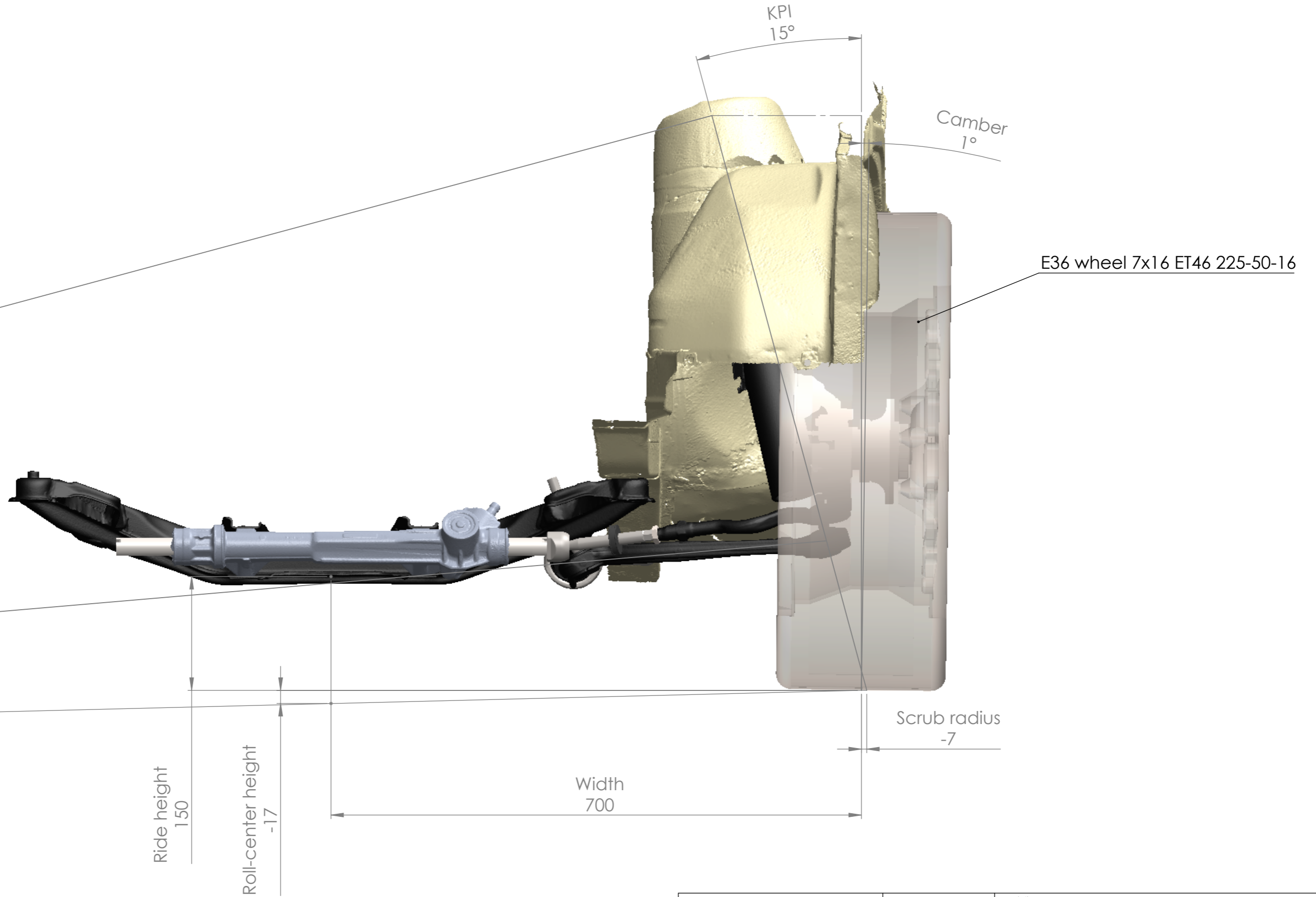
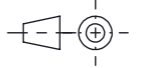

		General tolerance		Description	
		SFS-EN 2768-m		Front suspension geometry	
		Welded structures		Specification	
		EN-ISO 13920		E30 non-M with E36 non-M spindle and eccentric FCAB	
				Number	
				Rev	
Drawn By	Name	Date			
ML		03/07/2023			
Approved By					
Type			Finish	Material	Scale 1:5 Sheet 2 / 2 A3