

		General tolerance SFS-EN 2768-m		Description Front suspension geometry	
		Welded structures EN-ISO 13920		Specification E30 non-M with E36 M3 3.2 spindle and eccentric FCAB	
Drawn By	Name ML	Date 16/06/2023			Number
Approved By					Rev
Type			Finish	Material	Scale 1:5
					Sheet 1 / 2 A3

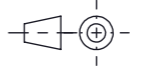
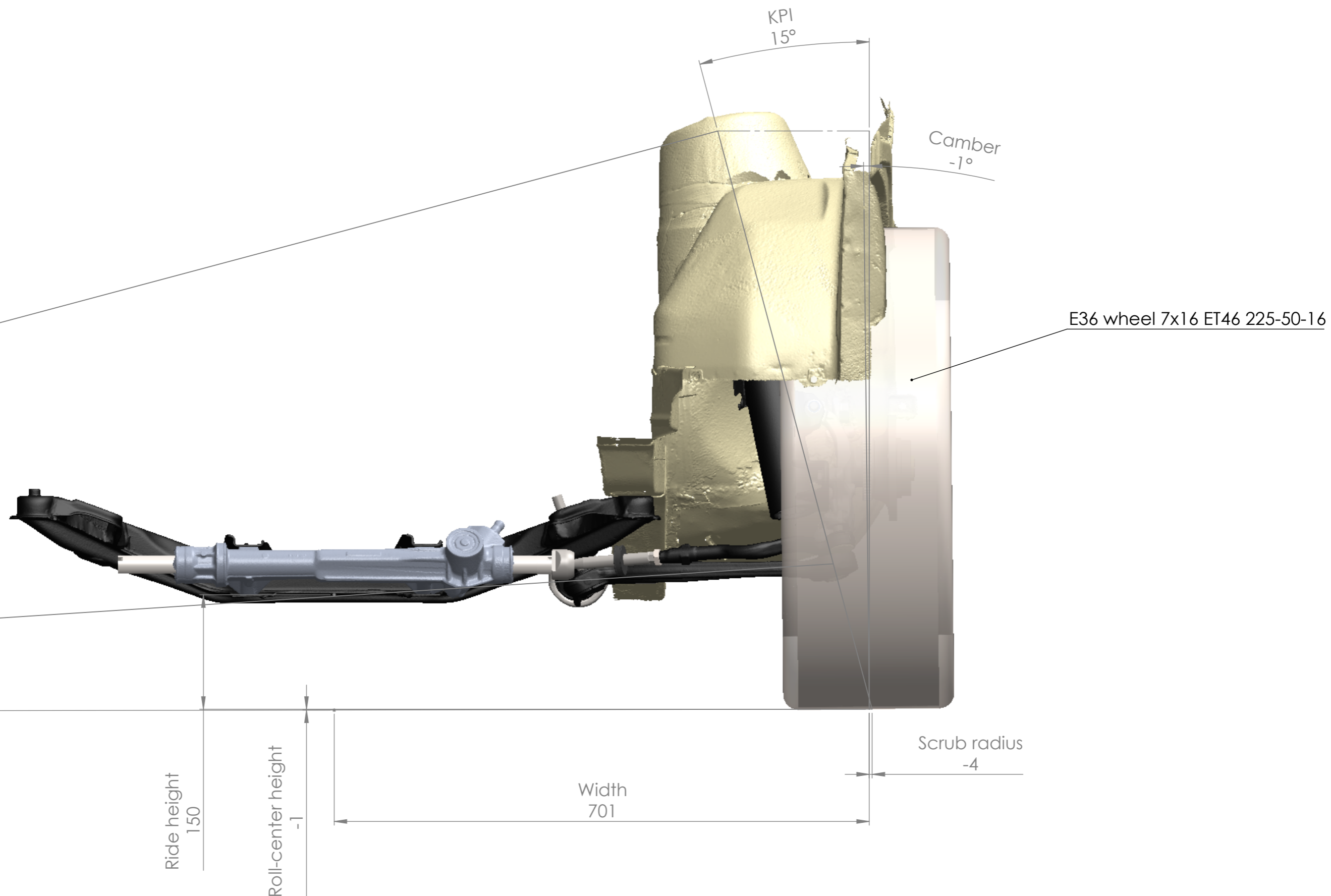
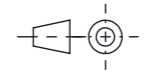

		General tolerance		Description	
		SFS-EN 2768-m		Front suspension geometry	
		Welded structures		Specification	
		EN-ISO 13920		E30 non-M with E36 M3 3.2 spindle and eccentric FCAB	
				Number	
Drawn By ML Approved By Type				Date 16/06/2023 Finish Material	

This document must not be copied without our written permission, and the contents thereof must not be imparted to a third party nor be used for any unauthorized purpose. contravention will be prosecuted.