



KaceFresh STIK

Ensuring **product freshness** continues to be a pain point in the cannabis industry, especially as it pertains to pre-rolls. Previous solutions have been incomplete by not allowing for **resealing** of cavities.

KacePack, a leader in the premium packaging space for the cannabis industry, has solved this issue by creating the KacePack Sticker Application Machine.

Features

- Air-tight sealing of each blister
- single, pen, multi-packs, gem trays etc.
- Daily output +2,000 pcs



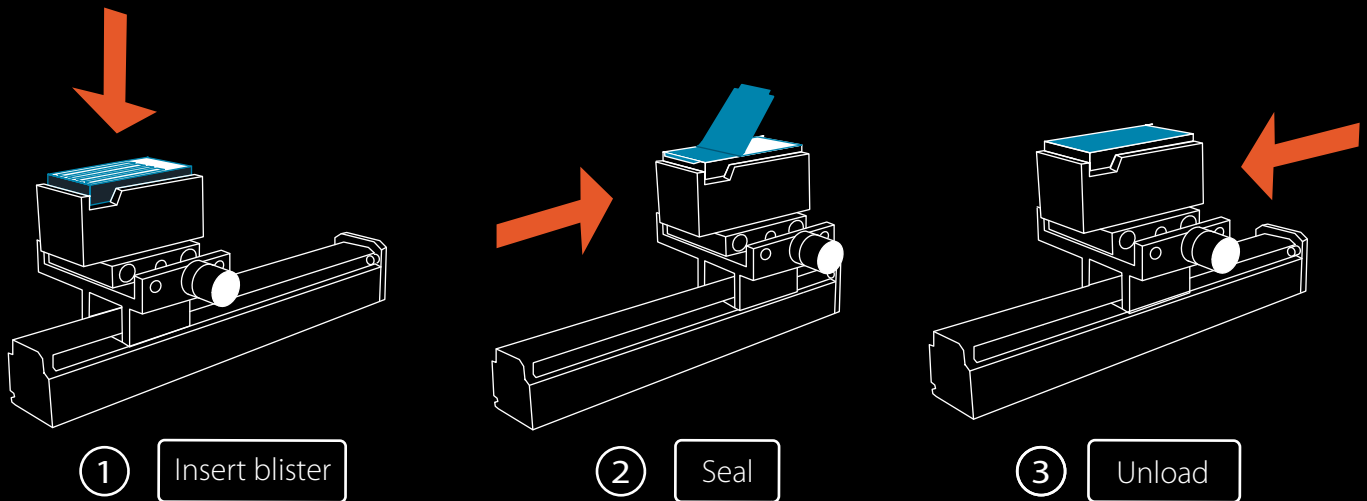
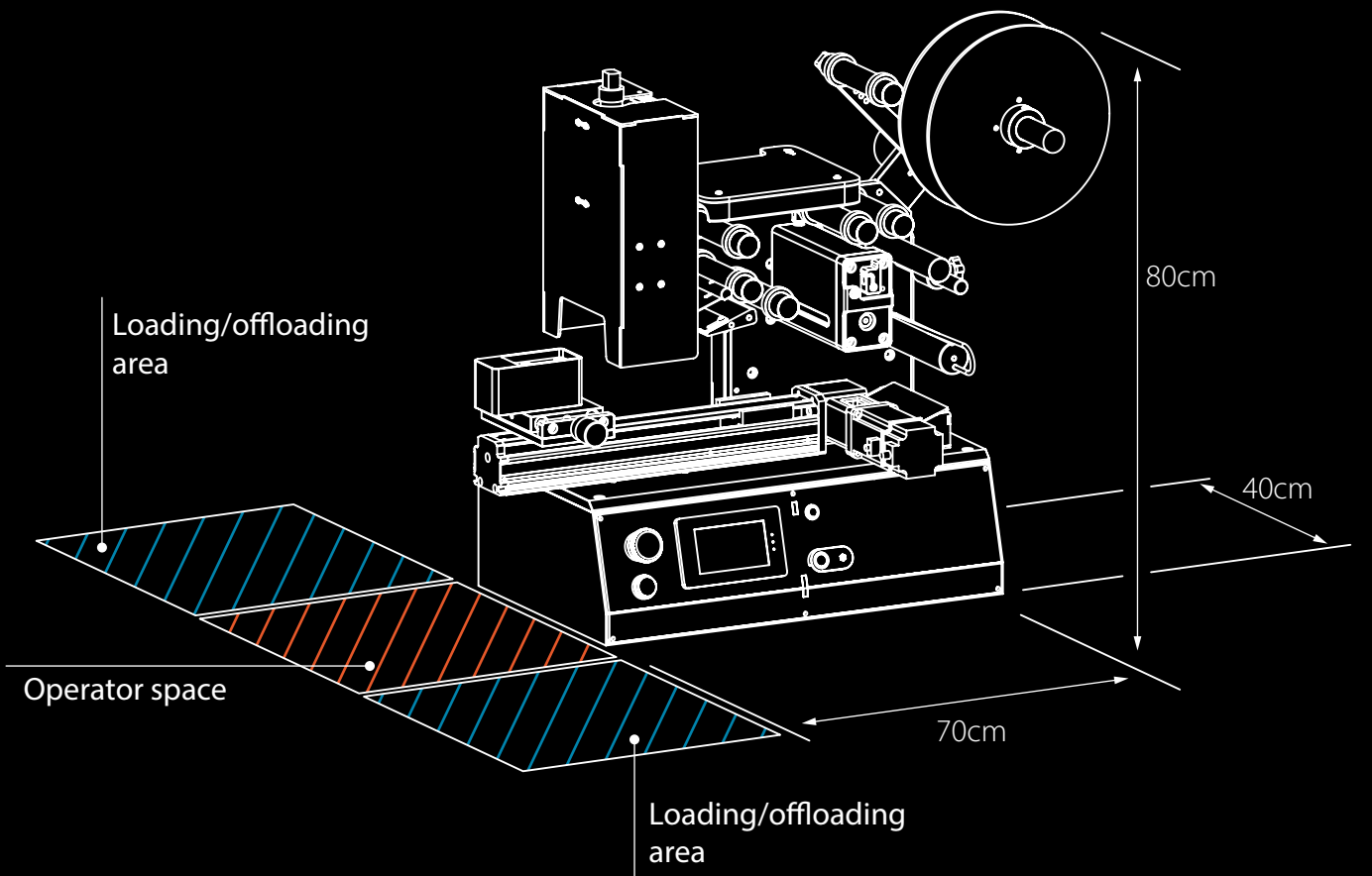

Operation requirement

- Standard US 110V/5A socket compatible
- Air pressure requirement - 60-80 psi
- Machine size approx 80cm x 70cm x 40cm
- 6.5 x 5.5 ft operation space required

Included in the order

- 1 x Reseal film applicator machine
- 1 x Roll of custom reseal stickers (2,000pcs)